

# **RISAFoundation**

**Rapid Interactive Structural Analysis – Foundations**

---

Verification Problems



26632 Towne Centre Drive, Suite 210  
Foothill Ranch, California 92610

(949) 951-5815  
(949) 951-5848 (FAX)

[www.risa.com](http://www.risa.com)

© 2020 RISA Tech, Inc. All Rights Reserved. RISA is part of the [Nemetschek Group](#).

No portion of the contents of this publication may be reproduced or transmitted in any means without the express written permission of RISA.

We have done our best to ensure that the material found in this publication is both useful and accurate. However, please be aware that errors may exist in this publication, and that RISA makes no guarantees concerning accuracy of the information found here or in the use to which it may be put.

© 2020 RISA Tech, Inc. All Rights Reserved. RISA is part of the Nemetschek Group.

No portion of the contents of this publication may be reproduced or transmitted in any means without the express written permission of RISA.

We have done our best to ensure that the material found in this publication is both useful and accurate. However, please be aware that errors may exist in this publication, and that RISA makes no guarantees concerning accuracy of the information found here or in the use to which it may be put.

Table of Contents

---

## Table of Contents

---

Verification Problem 1: Strip Footing Design .....	2
Verification Problem 2: Square Spread Footing #1.....	4
Verification Problem 3: Rectangular Spread Foot #1.....	6
Verification Problem 4: Pile Cap Shear.....	8
Verification Problem 5: Eccentrically Loaded Footing .....	12
Verification Problem 6: Cantilever Retaining Wall #1.....	14
Verification Problem 7: Cantilever Retaining Wall #2.....	16
Verification Problem 8: Rectangular Footing #2.....	19
Verification Problem 9: Square Footing #2 .....	21
Verification Problem 10: Cantilever Retaining Wall #3 .....	23
Verification Problem 11: Pile Cap Design Example.....	25

### ***Appendices***

Appendix A10: Cantilever Retaining Wall #3 Calculations.....	A10.1
Appendix A11: Pile Cap Design Example Calculations.....	A11.1



# Verification Overview

---

## Verification Methods

RISA maintains a large library of test problems used to validate the computational aspects of RISA programs. In this verification package we compare RISAFoundation to textbook and hand calculation examples listed within each problem.

The input for these test problems was formulated to test RISAFoundation's performance, not necessarily to show how certain structures should be modeled and in some cases the input and assumptions we use in the test problems may not match what a design engineer would do in a "real world" application.

The data for each of these verification problems is provided. The folder where these RISAFoundation files are located is in the ...\**Documents\RISA\Examples** directory and they are called **Verification Problem 1.fnd** (2, 3, etc). The PDF document is located in the ...\**Documents\RISA\Manuals** directory and is called **Foundation Verification Problems.pdf**

## Verification Version

This document contains problems that have been verified in RISAFoundation version 13.0.

# Verification Problem 1: Strip Footing Design

## Design of a Wall Footing

This problem represents a typical design of a wall footing. The hand verification of this problem can be taken directly from the 4<sup>th</sup> edition of Macgregor and Wight's, Reinforced Concrete Mechanics and Design (Example 16-1, p.802-805).

## Description/Problem Statement

A 12 in. thick concrete wall carries service dead and live loads of 10 kips per foot and 12.5 kips per foot, respectively. The allowable soil pressure,  $q_a$ , is 5 ksf at the level of the base of the footing, which is 5 ft below the final ground surface. The wall footing has a strength of 3 ksi and  $f_y = 60$  ksi. The density of the soil is 120 lb/ft<sup>3</sup>. **Note that the text does not account for the self-weight of the footing. Therefore, the RISA model has the density of the concrete material set to zero.**

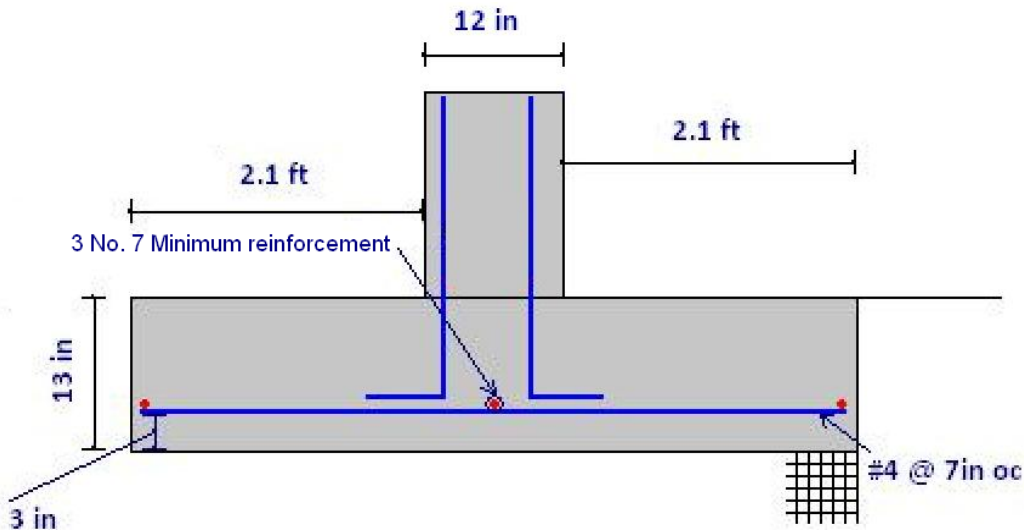

Figure 1.1 – RISAFoundation Model View

## Comparison

Comparison of Results (Units Specified Individually)			
Value	RISAFoundation	Text Value	% Difference
Factored Net Pressure, $q_{nu}$ (ksf)	6.19 <sup>1</sup>	6.19	0
$V_u$ (k/ft)	7.87 <sup>2</sup>	8.51 <sup>3</sup>	7.52
$\phi^*V_c$ (k/ft)	9.613	9.37 <sup>4</sup>	2.59
$M_u$ (k*ft/ft)	13.455	13.4	0.41
$\phi^*M_n$ (k*ft/ft)	14.268	14.0	1.91
$A_s$ min (in <sup>2</sup> )	1.451	1.45	0.07

Table 1.1 – Results Comparison

<sup>1</sup>The detail report for LC2 shows a Loading Diagram with 6.2 ksf on the toe end and 6.18 ksf on the heel. The average of these values is used in the above table.

<sup>2</sup>The detail report shows a  $V_u$  Toe = 7.88 k/ft and a  $V_u$  Heel = 7.86 k/ft. The average of these values is used in the above table.

<sup>3</sup>The value from the text is using a  $d = 8.5"$ . RISAFoundation is being more exact and using  $d = 13 - 3 - 0.5/2 = 9.75"$ . This produces a  $V_u = (1'/12") * (25" - 9.75") * 6.19 \text{ ksf} = 7.87 \text{ k/ft}$

<sup>4</sup>The value from the text is using  $d = 9.5"$  where RISAFoundation is being more exact and is using  $d = 9.75"$ .  $(9.75"/9.5") * 9.37 \text{ k/ft} = 9.617 \text{ k/ft}$ .

## Conclusion

In this example it is shown that the RISAFoundation calculations reasonably match the textbook design examples except in instances which are explained above.

# Verification Problem 2: Square Spread Footing #1

## Design of a Square Spread Footing

This problem represents a typical design of a square spread footing. The hand verification of this problem can be taken directly from the 4<sup>th</sup> edition of Macgregor and Wight's Reinforced Concrete Mechanics and Design (Example 16-2, p.805-810).

### Description/Problem Statement

A square spread footing supports an 18 in. square column supporting service dead and live loads of 400 kips and 270 kips, respectively. The column is built of 5 ksi concrete and has eight No. 9 longitudinal bars with  $f_y = 60$  ksi. The footing has concrete of strength 3 ksi and Grade-60 bars. The top of the footing is covered with 6 in. of fill with a density of 120 lb/ft<sup>3</sup> and a 6 in. basement floor. The basement floor loading is 0.1 ksf. The allowable bearing pressure on the soil is 6 ksf. Load and resistance factors are taken from ACI sections 9.2 and 9.3.

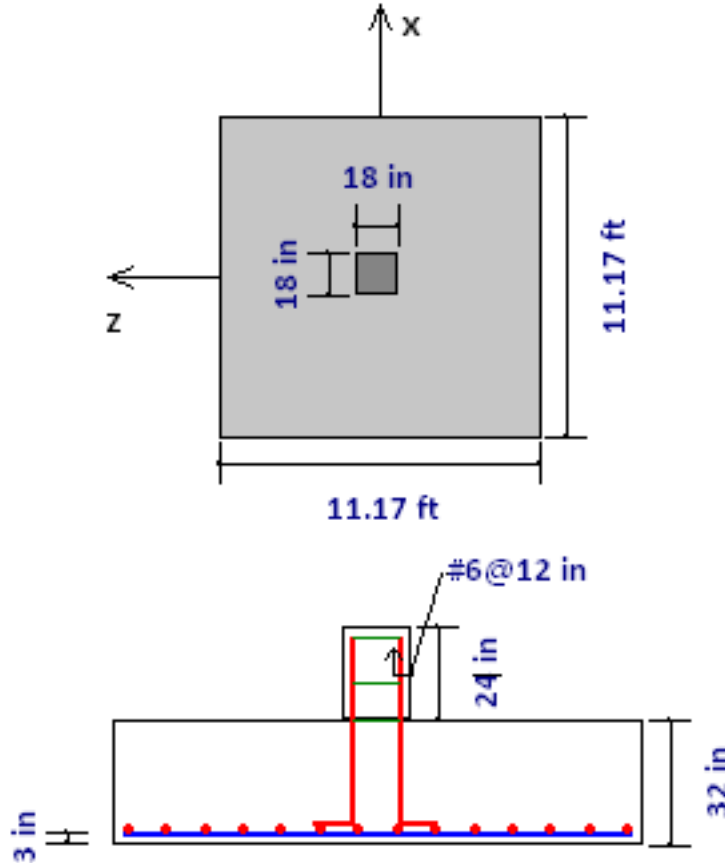

Figure 2.1 - RISAFoundation Model View

Solve the model and look at the detail report for the footing. Note that the text uses the net soil bearing to calculate the size of footing. This size is used directly in RISAFoundation and thus the soil overburden and self-weight are set to zero.



## Comparison

Comparison of Results (Units Specified Individually)			
Value	RISAFoundation	Text Value	% Difference
Soil Pressure, $q_u$ (ksf)	7.31 <sup>1</sup>	7.31	0
$V_u$ Punching (k)	804.591	804	0.07
$\phi * V_c$ Punching (k)	$\phi * 1128.747 =$ 846.56 ( $\phi = 0.75$ ) <sup>2</sup>	846	0.07
$V_u$ One-Way (k)	204.254	204	0.12
$\phi * V_c$ One-Way (k)	$\phi * 411.134 =$ 308.35 ( $\phi = 0.75$ ) <sup>3</sup>	308	0.11
$M_u$ (k*ft)	954.34	954	0.04
$A_s$ Required (in <sup>2</sup> )	7.763	8.41	7.7 <sup>3</sup>

Table 2.1 – Results Comparison

<sup>1</sup>To actually see this value, check the "Service" checkbox for LC 2 and solve the model. Then look at the detail report in the Soil Bearing section. When viewing the rest of the results, uncheck this checkbox and re-solve.

<sup>2</sup>In RISAFoundation the  $V_c$  value is reported without the  $\phi$  value. If the  $V_c$  value is multiplied by the text  $\phi$  then there is agreement.

<sup>3</sup>If you use RISA's value of  $A_s$  Required and calculate a new "a", you will get a  $\phi * M_n = 954.3$  k\*ft. This value exceeds  $M_u$ . The  $A_s$  required by the text is using a back of the envelope calculation to come up with  $A_s$  that is conservative in this case. When it comes to the calculation of  $\phi * M_n$  RISA is following ACI 318-11 Section 10.5.3 in providing  $(4/3) * A_s$  required, whereas the text is not.

## Conclusion

In this example it is shown that the RISAFoundation calculations reasonably match the textbook design examples except in instances which are explained above.

# Verification Problem 3: Rectangular Spread Foot #1

## Design of a Rectangular Spread Footing

This problem represents a typical design of a rectangular spread footing. The hand verification of this problem can be taken directly from the 4<sup>th</sup> edition of Macgregor and Wight's Reinforced Concrete Mechanics and Design (Example 16-3, p.810-812).

## Description/Problem Statement

Note that the text uses the net soil bearing to calculate the size of footing. This size is used directly in RISAFoundation and thus the soil overburden and self-weight are set to zero. This footing has been designed assuming that the maximum width is 9 ft. Following the hand calculation from the textbook the footing is found to be 9' wide by 13' 8" long by 32" thick. The example assumes the same net soil pressure of 7.31 ksf for both Example 16-2 and 16-3. However,  $(11.17 \text{ ft})^2 = 124.77 \text{ ft}^2$  and  $13.666 \text{ ft} * 9 \text{ ft} = 123 \text{ ft}^2$ . Thus, the smaller footing in this example produces a slightly higher soil pressure than the text.

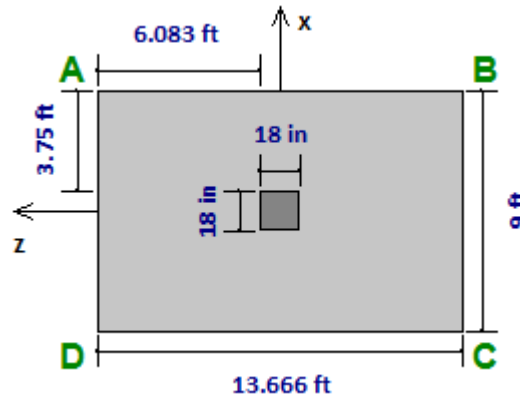

Figure 3.1 – RISAFoundation Detail Report View

The text example uses #8 bars in one direction and #5 bars in the other for the bottom steel. In RISAFoundation this is not possible, so two footings have been created to verify the calculations. Node N1 is using the #8 bars and node N2 is using #5 bars. When viewing the results in RISAFoundation use the footing node numbers given in Table 3.1 below.

## Comparison

Comparison of Results (Units Specified Individually)			
Value	RISAFoundation	Text Value	% Difference
$V_u$ One-Way (k) - N1	250.23 <sup>1</sup>	247	1.31
$\phi * V_c$ One-Way (k) - N1	$\phi * 331.263 = 248.45$ ( $\phi = 0.75$ ) <sup>2</sup>	248	0.18
$M_u$ Long (k*ft) - N1	1234.69	1217	1.45
$A_s$ Min Long (in <sup>2</sup> ) - N1	6.221	6.22	0.02
$A_s$ Provided Long (in <sup>2</sup> ) - N1	10.21 in <sup>2</sup> (13- #8 bars)	11.1 in <sup>2</sup> (14-#8 bars) <sup>3</sup>	8.02
$M_u$ Short (k*ft) - N2	712.5	702	1.5
$A_s$ Min Short (in <sup>2</sup> ) - N2	9.446	9.45	0.4
$A_s$ Provided Short (in <sup>2</sup> ) - N2	9.51 in <sup>2</sup> (31 - #5 bars; 25 are banded)	9.61 in <sup>2</sup> (31-#5 bars; 25 are banded)	0

Table 3.1 – Results Comparison

<sup>1</sup>The value from the text is using a net soil pressure of 7.31 ksf from Example 16-2. RISAFoundation is being more exact and calculating the actual net soil pressure as  $(1.2*400 \text{ k} + 1.6*270 \text{ k}) / 123 \text{ ft}^2 = 7.414 \text{ ksf}$ . This produces a  $V_u = (1'/12") * (73'' - 28'') * (9') * 7.414 \text{ ksf} = 250.23 \text{ k}$ .

<sup>2</sup>In RISAFoundation the  $V_c$  value is reported without the  $\phi$  value. If the  $V_c$  value is multiplied by the text  $\phi$  then there is agreement.

<sup>3</sup>In the text, approximate methods are used to determine  $A_s$  Req'd. We can see that the  $\phi * M_n = 1330 \text{ k*ft}$ . RISAFoundation is able to remove a bar and still produce a  $\phi * M_n$  greater than  $M_u$ .

## Conclusion

In this example it is shown that the RISAFoundation calculations reasonably match the textbook design examples, except in the instances explained above.

# Verification Problem 4: Pile Cap Shear

## Design for Depth of Footing on Piles

This problem represents the design for a footing supported on piles. The hand verification of this problem can be taken directly from PCA's Notes on ACI 318-11 Building Code Requirements for Structural Concrete (Example 22.7, p.22-20).

### Description/Problem Statement

- Footing Size = 8.5' x 8.5'
- Column Size = 16" x 16"
- Pile Diameter = 12 in.
- $f'_c$  = 4000 psi
- Load per Pile:
  - $P_D$  = 20 kips
  - $P_L$  = 10 kips

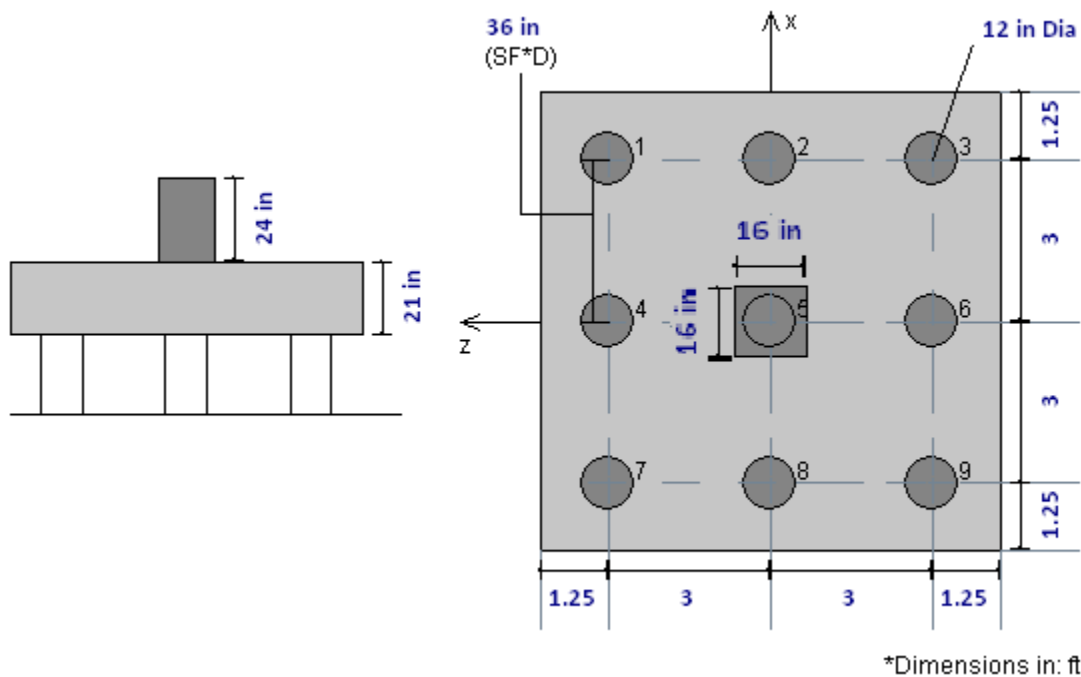

Figure 4.1 – RISAFoundation Detail Report View

Note that RISAFoundation will not place top steel reinforcement in a pile cap unless there is tension in the top face of the pile cap. For this reason, a 1 kip\*ft moment was added to the OL1 load category. This is to force top steel, as this affects the pile punching shear checks. If there is no reinforcement in the top, then the program considers the cap unreinforced for punching shear calculations.

### Comparison

Comparison of Results (Units in kips)			
Value	RISAFoundation	Text Value	% Difference
One-way Beam Shear Capacity, $\phi V_n$ (kips)	$0.75 \cdot 180.629 = 135.47^1$	135.4	0.05
Pedestal Punching Shear Capacity, $\phi V_n$ (kips)	$320/1.004 = 318.73^2$	319	0.08
Corner Pile Punching Shear Capacity, $\phi V_n$ (kips)	141.913	217	NA <sup>3</sup>

Table 4.1 – Results Comparison

<sup>1</sup>The program gives  $V_n$  explicitly, so the  $\Phi$  was multiplied in here to get  $\Phi \cdot V_n$ .

<sup>2</sup>The  $\Phi \cdot V_n$  is not given explicitly. The program gives the demand and the code check, so the calculation above shows what  $\Phi \cdot V_n$  is in RISAFoundation.

<sup>3</sup>There are several factors to account for the difference in value. For one, we are transforming the round punching shear perimeter into an equivalent square perimeter. Second, and more importantly, the punching shear capacity is based on the smallest possible shear perimeter,  $b_o$ . The example in the PCA notes assumes that the punching shear perimeter occurs a distance of  $d/2$  all the way around the pile, as shown in Figure 4.2 below.

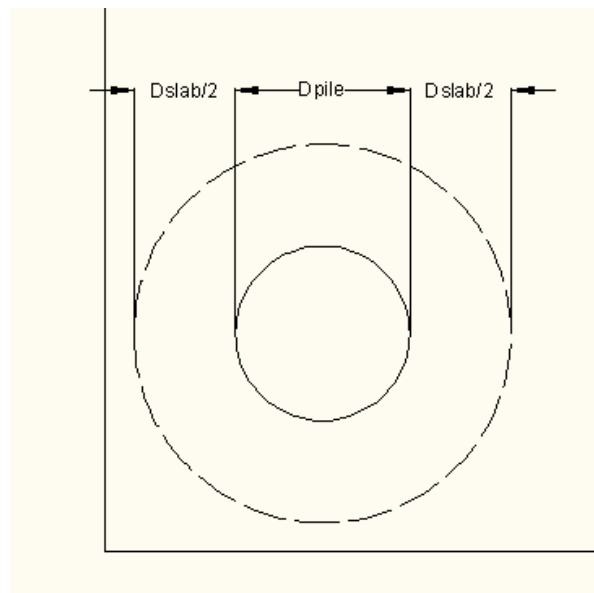

Figure 4.2

In reality, the crack will perpetuate from the face of the pile through the thickness of the pile cap to a distance “ $d$ ” from the edge of the pile.  $D/2$  occurs midway along the crack and is used for calculation purposes. A more realistic view of the crack is shown in elevation view in Figure 4.3.

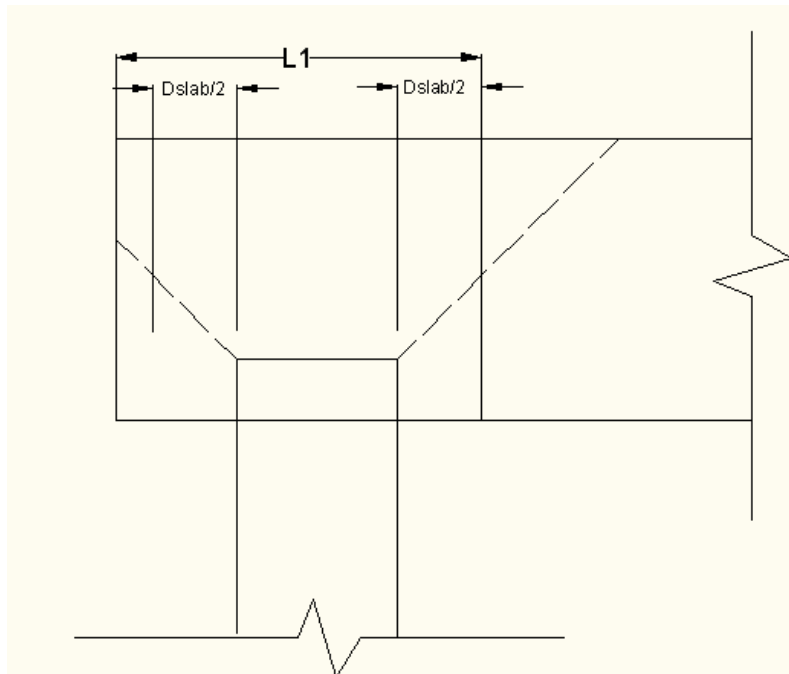

Figure 4.3

As a result, the punching shear perimeter cannot be taken as shown in the PCA notes. Realistically, the corner will break out, resulting in a partial perimeter. A diagram of the perimeter used in RISAFoundation, including the square perimeter adjustment, is shown in Figure 4.4.

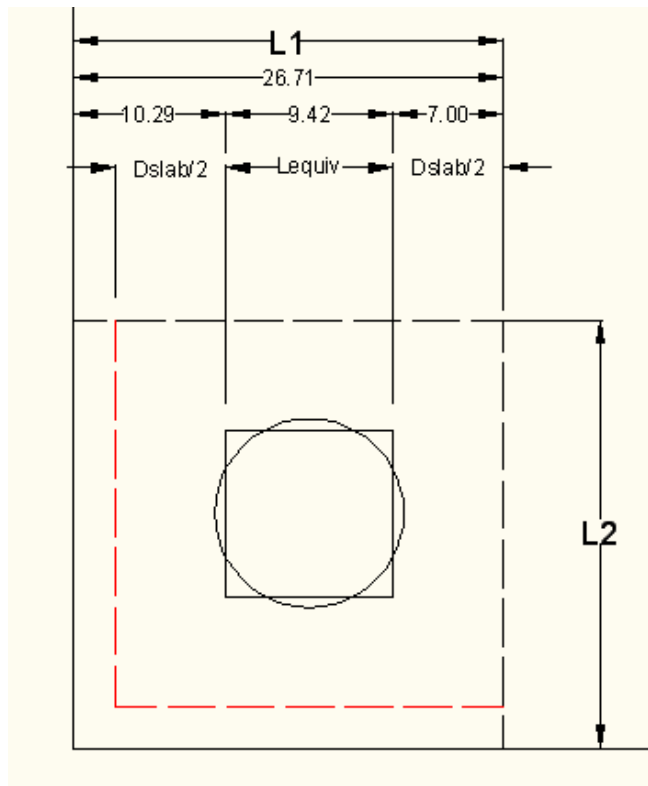

Figure 4.4

## **Conclusion**

In this example it is shown that the RISAFoundation calculations reasonably match the textbook design examples.

# Verification Problem 5: Eccentrically Loaded Footing

## Footing Under Biaxial Moment

This problem represents the case where a footing may be subjected to an axial force and biaxial moments about its x- and y-axes. This example comes from the Design of Reinforced Concrete Structures, copyright 1985 Hassoun (Example 13.7, p.409-413).

### Description/Problem Statement

A 12" by 24" column of an unsymmetrical shed is subjected to an axial load  $P_D = 220$  kips and a moment  $M_D = 180$  k-ft due to dead load, and an axial load  $P_L = 165$  kips and a moment  $M_L = 140$  k-ft due to live load. The base of the footing is 5 ft. below final grade and the allowable soil bearing pressure is 5 ksf. The footing has strength of 4 ksi and a steel yield of 40 ksi. **Note that the text does not account for the self-weight of the footing. Therefore, the RISA model has the density of the concrete material set to zero.**

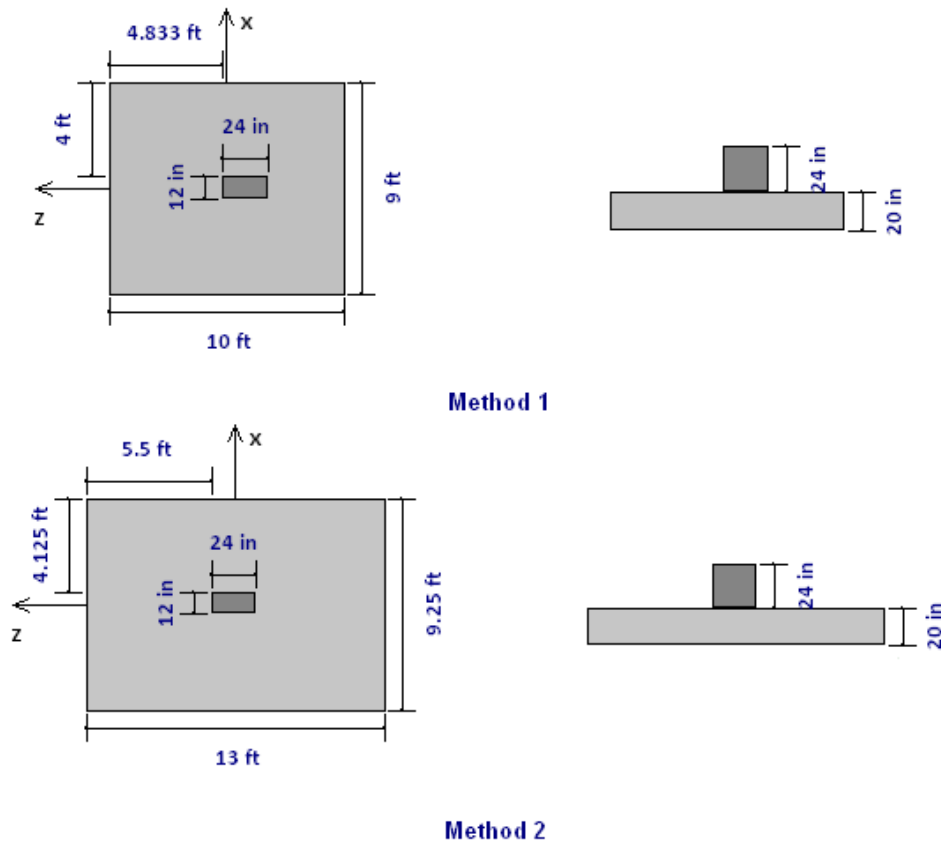

Figure 5.1 - RISAFoundation Detail Report View



## Comparison

Comparison of Results (Units Specified Individually)			
Value	RISAFoundation	Text Value	% Difference
Method 1 Soil Pressure, $q_n$ (ksf)	4.283	$(87.1/90)*4.42$ $= 4.277^1$	0.07
Method 1 $M_u$ -xx (k*ft)	687.2	687.4	0.03
Method 1 $M_u$ -zz (k*ft)	523.11	523.2	0.02
Method 2 Soil Pressure Max, $q_n$ (ksf)	4.43	4.42 <sup>2</sup>	0.23
Method 2 Soil Pressure Min, $q_n$ (ksf)	1.973	1.98	0.35
Method 2 $M_u$ -xx (k*ft)	873.6	873	0.07

Table 5.1 – Results Comparison

<sup>1</sup>The text book calculates a required area of 87.1 in<sup>2</sup> and uses an area of 90 in<sup>2</sup>. Thus, their value has been adjusted.

<sup>2</sup>The text book example has an error. They state that  $3.20 + 1.22 = 4.22$  ksf when calculating  $q_{max}$  for method 2. This should be 4.42 ksf.

## Conclusion

In this example it is shown that the RISAFoundation calculations reasonably match the textbook design examples.

# Verification Problem 6: Cantilever Retaining Wall #1

## Design of a Cantilever Retaining Wall

This example comes from the Principles of Foundation Engineering, 3rd Edition by Das, copyright 1995. This is example A.8 on P798. In this problem we will compare the serviceability checks for a retaining wall example to the output from RISAFoundation.

### Description/Problem Statement

The cross section of a cantilever retaining wall is shown below. For this case,  $f_y = 413.7 \text{ MN/m}^2$  and  $f'_c = 20.68 \text{ MN/m}^2$ .

#### Notes:

- RISAFoundation uses Rankine's method to calculate lateral soil pressure coefficients. This example uses Coulombs method. Because of this the  $K_{Lat Toe}$  was set to 2.04.
- The coefficient of friction in this example is calculated as:  $\tan(2/3 * \phi) = 0.237$ . This is the value entered in the program.
- The ultimate bearing pressure in this example is calculated as 574.07, so this is entered as the allowable bearing in the program.

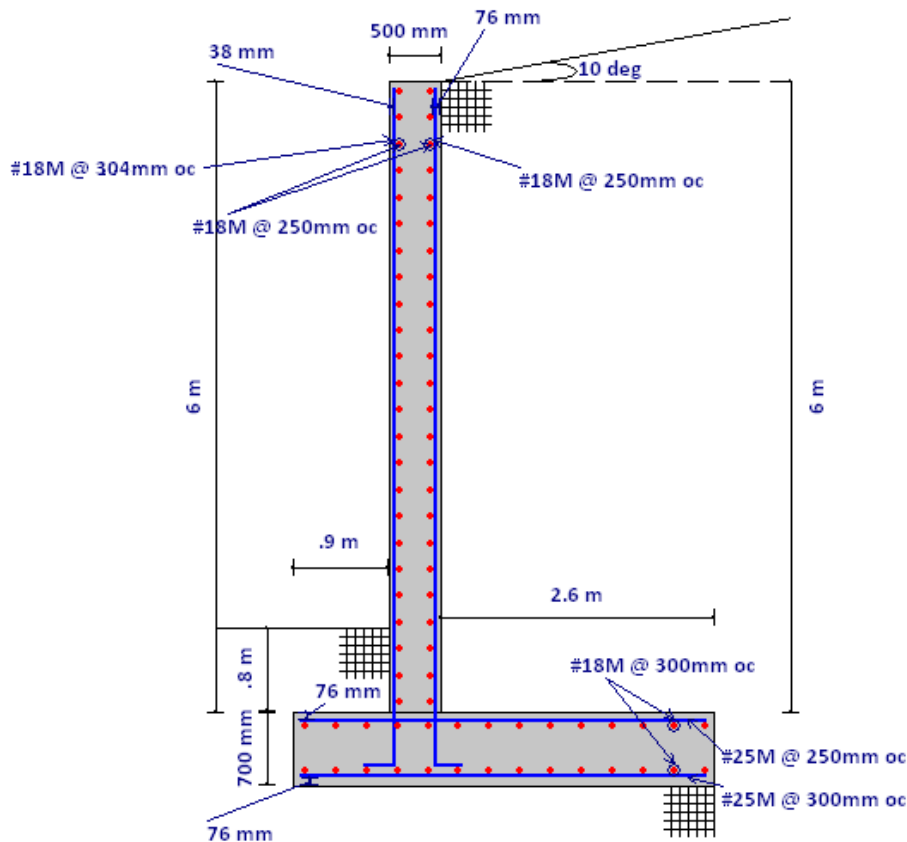

Figure 6.1 – RISAFoundation Detail Report View

## Comparison

Comparison of Results (Units Specified Individually)			
Value	RISAFoundation	Text Value	% Difference
$M_{resist}$ Against Overturning (kN-m/m)	1061.143	1044.3 (1128.98) <sup>1</sup>	1.61
$M_{overturn}$ (kN-m/m)	379.047	379.25	0.05
$V_{resist}$ Against Sliding (kN/m)	152.544	433.17 - 106.67 - 171.39 = 155.1 <sup>2</sup>	1.65
$V_{sliding}$ (kN/m)	158.853	158.95	0.06
Max Bearing Pressure (kPa)	204.905	189.2 <sup>3</sup>	8.30
Bearing UC	.357	189.2/574.07 = .329 <sup>3</sup>	8.5

Table 6.1 – Results Comparison

<sup>1</sup>The textbook accounts for the sloping outer face of the wall, which RISAFoundation does not. Also, the vertical portion of the active pressure soil force in the text is assumed to act at the edge of the heel. In RISAFoundation, we assume this force acts at the inside face of the wall. These differences would equal (1128.98 kN-m/m) - (11.79 kN-m/m) - (2.6 m \* 28.03 kN/m = 1044.312 kN-m/m).

<sup>2</sup>RISAFoundation assumes cohesion-less soil. The textbook assumes cohesion, resulting in a  $V_{resist} = 111.5 \text{ kN/m} + 106.7 \text{ kN/m} + 215 \text{ kN/m} = 433.17 \text{ kN/m}$ . The 106.7 comes from a cohesion term that is not accounted for in RISAFoundation. The 215 comes from passive pressure force including cohesion. The cohesion term = 171.39 kN/m which is not accounted for in RISAFoundation. Accounting for these cohesion differences between RISAFoundation and the text gives a value =  $433.17 - 106.67 - 171.39 = 155.1 \text{ kN/m}$ .

<sup>3</sup>The text uses the  $M_{resist}$  to calculate the bearing pressure. Because of the differences listed above in note 1, the pressure calculation is different.

## Conclusion

In this example it is shown that the RISAFoundation calculations reasonably match the textbook design examples after accounting for differences in calculation procedures.

# Verification Problem 7: Cantilever Retaining Wall #2

## Design of Reinforced Concrete Cantilever Retaining Walls

In this problem we will compare the serviceability checks for a retaining wall example to the output from RISAFoundation. This example comes from Reinforced Concrete Design, Third Edition, copyright 1992 by Spiegel and Limbrunner. This is design example 8-1 on P214.

### Description/Problem Statement

Design Data: unit weight of earth  $w_e = 100 \text{ lb/ft}^3$ , allowable soil pressure = 4,000 psf, equivalent fluid weight  $K_a w_e = 30,100 \text{ lb/ft}^3$ , and surcharge load  $w_s = 400 \text{ psf}$ . The desired factor of safety against overturning is 2.0 and against sliding is 1.5.

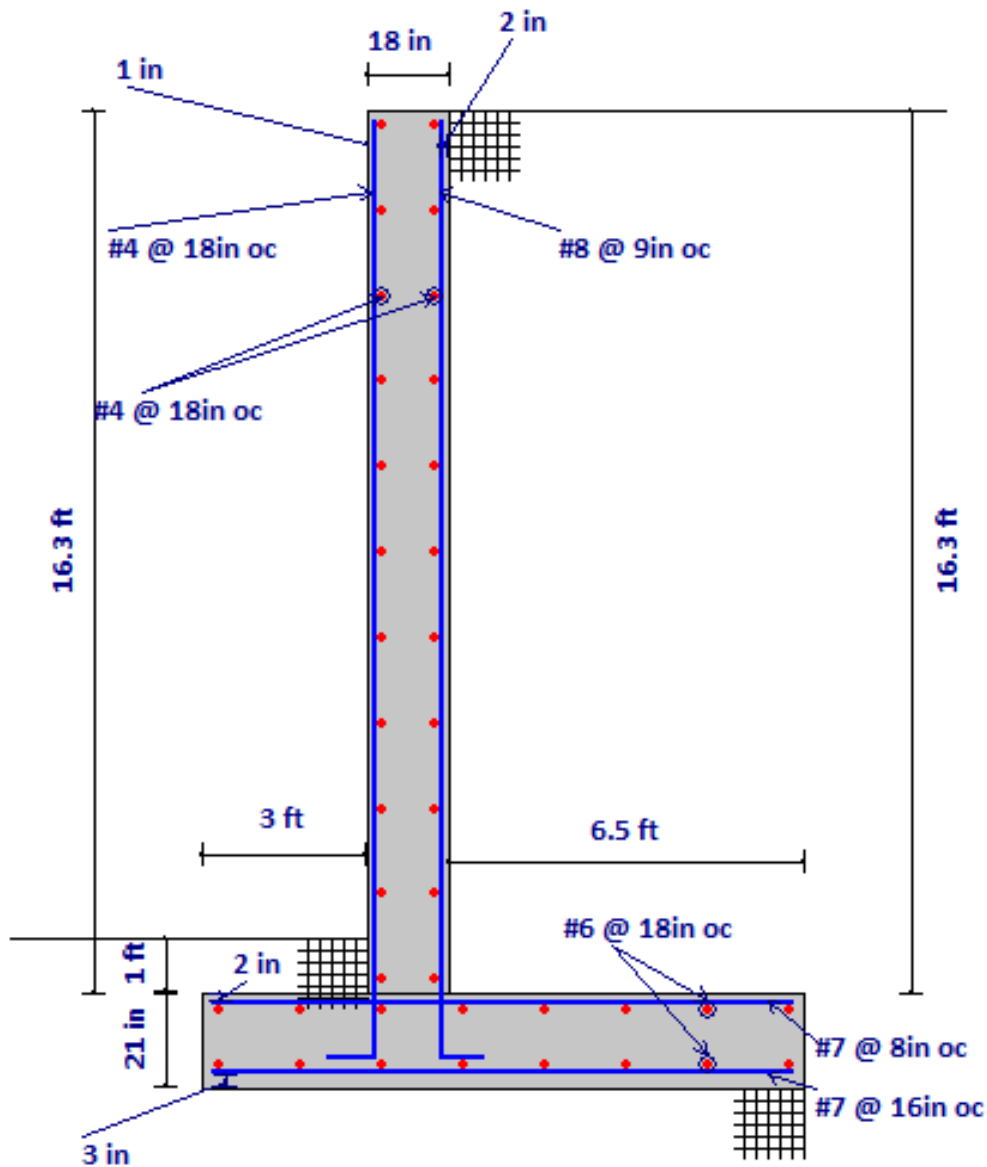

Figure 7.1 – RISAFoundation Detail Report View

Note: The shear key has been omitted from the RISAFoundation model, as this will affect the calculations for sliding and overturning. The text example did not assume a key when performing those calculations.

## Comparison

Value	RISAFoundation	Text Value	% Difference
$M_{\text{resist Against Overturning}}$ (k*ft)	131.169	131.7	0
$M_{\text{overturn}}$ (k*ft)	48.6	48.6	0
$V_{\text{resist Against Sliding}}$ (kips)	10.008	9.855	1.55
$V_{\text{sliding}}$ (kips)	7.02	7.02	0
Max Soil Pressure (ksf)	3.101	3.043	1.9
$M_u$ of Heel (k*ft)	46.695	67.65	NA <sup>1</sup>
$V_u$ Heel (k*ft)	11.221	20.82	NA <sup>1</sup>
$\phi V_n$ of Heel (kips)	$18.301 * (0.85/0.75) = 20.74^2$	20.76	0.1
$A_s$ Top (in <sup>2</sup> )	#7 Bars @ 8" oc	#7 Bars @ 8" oc	0
$M_u$ of Toe (k*ft)	18.473	20.476	NA <sup>3</sup>
$V_u$ of Toe (kips)	6.466	13.07	NA <sup>4</sup>
$\phi V_n$ of Toe (kips)	$17.315 * (0.85/0.75) = 19.62^2$	19.64	0.1
$A_s$ Bot (in <sup>2</sup> )	#7 Bars @ 16" oc	#7 Bars @ 16" oc	0
$M_u$ Stem Base (k*ft)	63.4	63.431	0.05
$V_u$ Stem Base (kips)	10.023 <sup>5</sup>	10.049	0.26
$\phi V_n$ of Stem (kips)	$15.281 * (0.85/0.75) = 17.318^2$	17.391	0.42
$A_s$ Stem (in <sup>2</sup> )	#8 Bars @ 9" oc	#8 Bars @ 9" oc	0

Table 7.1 – Results Comparison

<sup>1</sup>In the text example the "relieving" moment due to the upward soil pressure on the heel is not accounted for. This is accounted for in RISAFoundation.

<sup>2</sup>This value is being adjusted for the change in  $\phi_{\text{shear}}$  from 0.85 to 0.75.

<sup>3</sup>In the text example the "relieving" moment due to the downward soil pressure on the toe is not accounted for. This is accounted for in RISAFoundation.

<sup>4</sup>In the text example, the shear location is taken as the face of wall. In RISAFoundation, the shear is checked at a distance "d" from the wall.

<sup>5</sup>View detail report for Load Combination 2: Strength to see this value.

## **Conclusion**

In this example it is shown that the RISAFoundation calculations reasonably match the textbook design example.

# Verification Problem 8: Rectangular Footing #2

## Rectangular Reinforced Concrete Footings

This problem represents a typical design of a rectangular spread footing. This example comes from Reinforced Concrete Design, Third Edition, copyright 1992 by Spiegel and Limbrunner. This is design example 10-4 on P310.

### Description/Problem Statement

A concrete footing 4 ft. below the finished ground line supports an 18-in. square tied interior concrete column. The total footing thickness is 24 in. One dimension of the footing is limited to a maximum of 7 ft.

Service DL	= 175 kips
Service LL	= 175 kips
$f'_c$ (footing and column)	= 3000 psi
Steel Yield $f_y$	= 60 ksi
Longitudinal column steel	= No. 8 bars
Soil Density	= 100 lb/ft <sup>3</sup>
Allowable Soil Pressure	= 5 ksf
Effective Allowable Soil Pressure	= 4.50 ksf

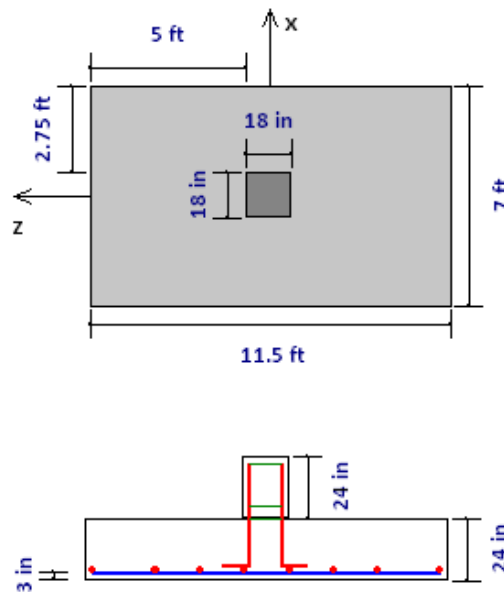

Figure 8.1 – RISAFoundation Detail Report View

Note that the self-weight and overburden were input as zero and the allowable soil pressure was added directly as 4.50 ksf.

## Comparison

Comparison of Results (Units Specified Individually)			
Value	RISAFoundation	Text Value	% Difference
Factored Soil Pressure, $q_u$ (ksf)	6.739 <sup>1</sup>	6.74	0.01
Shear Demand, $V_u$ two-way (k)	474.921	475	0.02
Shear Capacity, $\phi V_n$ two-way (k)	$\phi^*666.031 = 566.13 (\phi=0.85)^2$	566	0.02
Shear Demand, $\phi V_u$ one-way (k)	157.246	157.1	0.09
Shear Strength, $\phi V_n$ one-way (k)	$\phi^*184.035 = 156.43 (\phi=0.85)^2$	156.4	0.17
Bending Moment, $M_u$ long direction (k*ft)	589.67	590	0.06
Bending Moment, $M_u$ short direction (k*ft)	293.05	293	0.02
$A_s$ required long direction (in <sup>2</sup> )	6.884	6.9	0.23
$A_s$ required short direction (in <sup>2</sup> )	3.303	$4.4/(4/3) = 3.3^3$	0.09
$A_s$ required T & S (in <sup>2</sup> )	5.962	5.96	0.03
Footing Bearing Strength (in <sup>2</sup> )	$\phi^*1652.4 = 1156.68 (\phi=0.70)^4$	1157	0.03
Factored Bearing Load, $P_u$ (k)	542.5	542.5	0.00

Table 8.1 – Results Comparison

<sup>1</sup>To actually see this value, check the "Service" checkbox for LC 2 and solve the model. Then look at the detail report in the Soil Bearing section. When viewing the rest of the results, uncheck this checkbox and re-solve.

<sup>2</sup>In RISAFoundation the  $V_c$  value is reported without the  $\phi$  value. If the  $V_c$  value is multiplied by the text  $\phi$  then there is good agreement.

<sup>3</sup>In the text they are multiplying by  $4/3 * A_{s \text{ required}}$  as their value. RISAFoundation will do this as well when actually reinforcing the footing, however, we also report the  $A_{s \text{ required}}$  itself.

<sup>4</sup>In RISAFoundation the  $B_c$  value is reported without the  $\phi$  value. If the  $B_c$  value is multiplied by the text  $\phi$  then there is good agreement.

## Conclusion

In this example it is shown that the RISAFoundation calculations reasonably match the textbook design example.



## Verification Problem 9: Square Footing #2

### Design for Base Area, Depth, and Reinforcement of Footing

This problem represents a typical design of a square spread footing. The hand calculation comparison of this example comes from the [PCA Notes for the ACI 318-11 Example 22.1, 22.2 and 22.3](#) (all in one problem) on page 22-7.

#### Description/Problem Statement

Service Dead Load	= 350 kips
Service Live Load	= 275 kips
Service Surcharge	= 100 psf
Weight of Soil and Concrete above Footing Base	= 130 lb/ft <sup>3</sup>
Net Allowable Soil Pressure	= 3.75 ksf

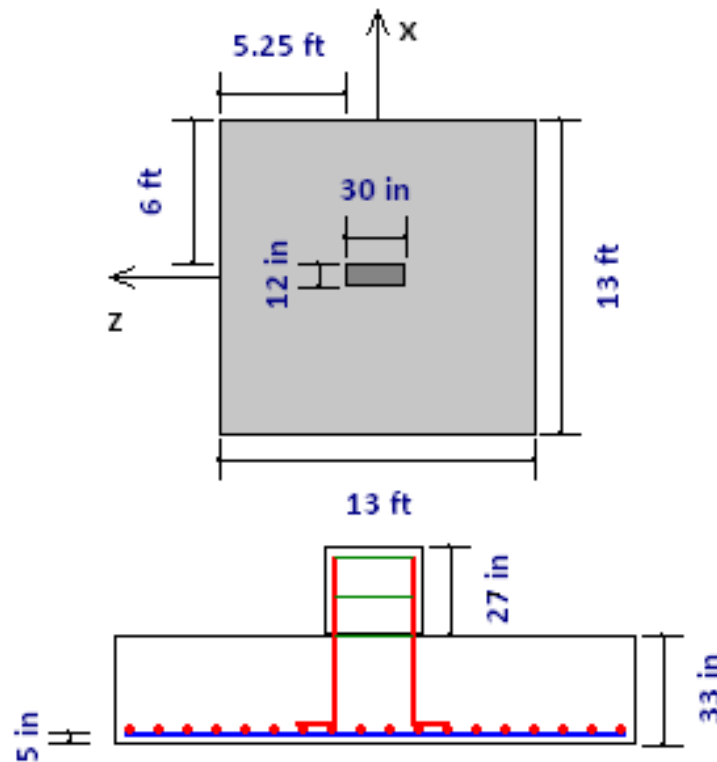

Figure 9.1 – RISAFoundation Detail Report View

#### Notes:

- Because the example does not use the self-weight of the footing in the calculation and instead just gives an average weight between the soil and concrete, the density of

concrete has been set to 0. The Overburden has also been set to zero. Thus, the allowable soil pressure is simply added directly as 3.75 ksf.

- The  $d_{foot}$  value for footings in RISAFoundation = footing thickness – bottom cover –  $1 \cdot d_b$ . The examples use a  $d = 28"$ , thus the bottom cover is set to  $4"$ .

### Comparison

Comparison of Results (Units Specified Individually)			
Value	RISAFoundation	Text Value	% Difference
Ex 22.1: $q_s$ (ksf)	5.089 <sup>1</sup>	5.1	0.22
Ex 22.2 Shear Demand, $V_u$ one way (k)	242.564	243	0.18
Ex 22.2 Shear Capacity, $\phi V_n$ one way (k)	$\phi * 478.5 = 358.868$ $(\phi = 0.75)^2$	359	0.04
Ex 22.2 Shear Demand, $V_u$ two way (k)	778.014	780	0.25
Shear Capacity, $\phi V_n$ two way (k)	$\phi * 1082 = 811.593$ $(\phi = 0.75)^2$	812	0.05
Ex 22.2 Bending Moment, $M_u$ (k*ft)	1190.77	1193	0.12
Ex 22.3 $A_s$ required (in <sup>2</sup> )	9.704	9.6	1.08

Table 9.1 – Results Comparison

<sup>1</sup>To actually see this value, check the "Service" checkbox for LC 2 and solve the model. Then look at the detail report in the Soil Bearing section. When viewing the rest of the results, uncheck this checkbox and re-solve.

<sup>2</sup>RISAFoundation presents the  $V_c$  value without  $\phi$ . When you multiply  $V_c$  by  $\phi$  you get agreement.

### Conclusion

In this example it is shown that the RISAFoundation calculations reasonably match the PCA Notes design examples.

# Verification Problem 10: Cantilever Retaining Wall #3

## Design of a Cantilever Retaining Wall

In this example we have a non-sloping back-filled retaining wall with a load surcharge and a water table present. The wall and footing are not poured monolithically. Footing dowels occur at both faces of the wall and are of the same size and spacing as the wall reinforcement. A load combination of  $1.0 \cdot DL + 1.0 \cdot LL + 1.0 \cdot HL$  is used for the service LC and a load combination of  $1.2 \cdot DL + 1.6 \cdot LL + 1.6 \cdot HL$  is used for the strength LC.

In this example RISAFoundation's values are compared to the values obtained from a hand calculation done for soil pressures, stability and all design aspects of the wall. This hand calculation is located in Appendix A10.

### Description/Problem Statement

This problem comes from a hand calculation verification. It is testing all results for retaining wall stability, soil pressure calculations and reinforcement design.

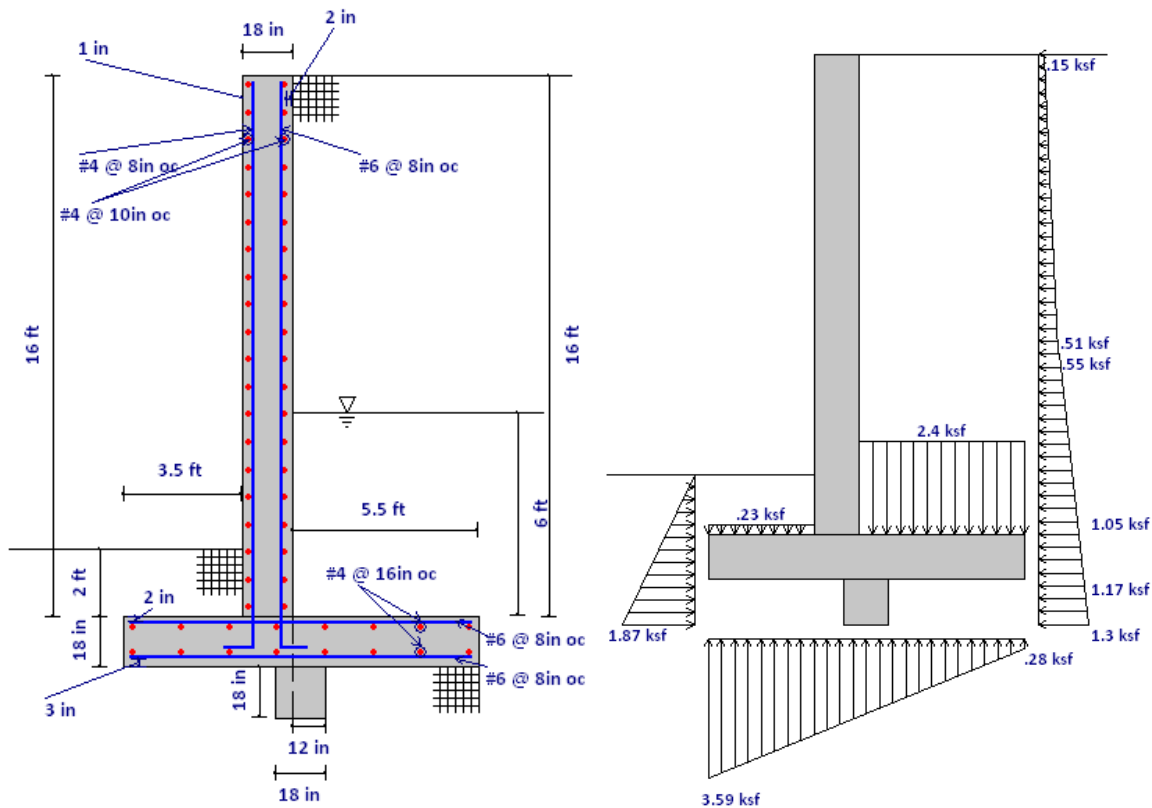

Figure 10.1 – RISAFoundation Detail Report View

Note: The retaining wall is cantilevered and the base is not restrained against sliding.

## Comparison

This section is the tabular comparison of the RISAFoundation answers and the summary from the detailed validation results.

Comparison of Results (Units Specified Individually) <sup>1,2</sup>			
Value	RISAFoundation	Hand Calculation	% Difference
Lateral Earth Pressures			NA
K <sub>Lat Heel</sub>	0.307	0.307	0
K <sub>Lat Heel Sat</sub>	0.333	0.333	0
K <sub>Lat Toe</sub>	3.255	3.255	0
Stability Checks			
Overturing SF Min/SF	0.659	0.659	0
Sliding SF Min/SF	1.176	1.176	0
Wall Design			
UC Max Int	1.664	1.678	0.834
Shear UC Max	0.624	0.627	0.478
Dowel Shear UC Max	0.455	0.455	0
Footing Soil Pressures			
q <sub>max</sub> (ft)*	5.6	5.603	0.054
L <sub>soil Length</sub> (ft)*	9.09	9.090	0
Footing Design			
Shear UC Heel	0.746	0.746	0
Moment UC Heel	0.967	0.967	0
Shear UC Toe	0.597	0.597	0
Moment UC Toe	0.63	0.630	0

Table 10.1 – Results Comparison

<sup>1</sup>Note that the values shown here can be seen graphically by looking at the detail report for load combination 2.

<sup>2</sup>See Appendix A10 for an in-depth hand calculation.

## Conclusion

In this example it is shown that the RISAFoundation calculations reasonably match the hand calculated design example.

# Verification Problem 11: Pile Cap Design Example

---

## Design of a Pile Cap

In this example we have a pile cap with 12 HP14x102 piles providing support. The piles have an 85 kip compression capacity, a 12 kip tension capacity and a 14 kip shear capacity. The pile cap is 42" thick with a 6" pile embedment and made from 4 ksi lightweight concrete. A load combination of  $1.0*DL + 1.0*LL$  is used for the service LC and a load combination of  $1.2*DL + 1.6*LL$  is used for the strength LC.

## Description/Problem Statement

In this example RISAFoundation's values are compared to the values obtained from a hand calculation done for all aspects of the pile cap. This hand calculation is located in Appendix A11.

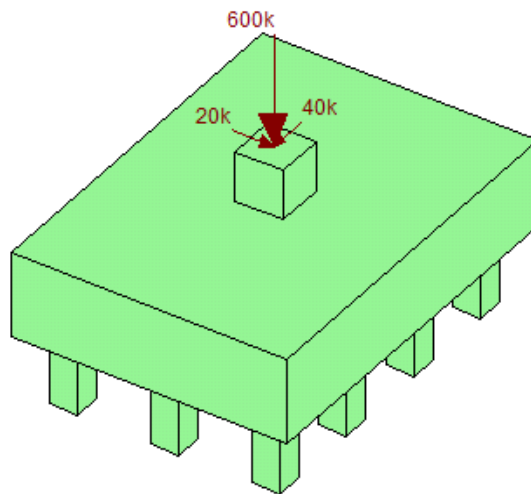

Figure 11.1 – RISAFoundation Model View

## Comparison

This section is the tabular comparison of the RISAFoundation answers and the summary from the detailed validation results.

Comparison of Results (Units Specified Individually) <sup>1,2</sup>			
Value	RISAFoundation	Hand Calculation	% Difference
Flexural Checks			
M <sub>uxx</sub> (k-ft)	1432.026	1438	0.42
M <sub>uzz</sub> (k-ft)	937.138	932.8	0.46
A <sub>sminx</sub> (in <sup>2</sup> )	13.835	13.835	0
A <sub>sminz</sub> (in <sup>2</sup> )	10.13	10.13	0
A <sub>sflexx</sub> bot (in <sup>2</sup> )	20.588	20.588	0
A <sub>sflexz</sub> bot (in <sup>2</sup> )	15.075	15.075	0
UC Mx	0.755	0.753	0.27
UC Mz	0.445	0.488	8.81
Punching Shear Checks			
Pedestal Punching UC	0.719	0.719	0
Pile 4 Punching Capacity (kips)	220.284	220.284	0
Pile 4 Punching UC	0.399	0.399	0
One Way Shear Checks			
Shear Capacity V <sub>cx</sub> (kips)	1186.972	1187	0
Shear Capacity V <sub>cz</sub> (kips)	585.931	591.221	0.89
Pedestal Shear Capacities			
V <sub>c</sub> (kips)	48.952	48.952	0
V <sub>s</sub> (kips)	50.658	50.658	0

Table 11.1 – Results Comparison

<sup>1</sup>Note that the values shown here can be seen graphically by looking at the detail report for the pile cap.

<sup>2</sup>See Appendix A11 for an in-depth hand calculation.

## Conclusion

In this example it is shown that the RISAFoundation calculations reasonably match the hand calculated design example.