

RISACconnection

Rapid Interactive Structural Analysis for Connections

Version 17.0 - General Reference



RISA Tech, Inc.

27442 Portola Parkway, Suite 200

Foothill Ranch, California 92610

(949) 951-5815

(949) 951-5848 (FAX)

risa.com

Copyright © 2025 RISA Tech, Inc. All Rights Reserved. RISA is part of the [Nemetschek Group](#). No portion of the contents of this publication may be reproduced or transmitted in any means without the express written permission of RISA Tech, Inc. RISA and the RISA logo are registered trademarks of RISA Tech, Inc.

We have done our best to ensure that the material found in this publication is both useful and accurate. However, please be aware that errors may exist in this publication, and that RISA Tech, Inc. makes no guarantees concerning accuracy of the information found here or in the use to which it may be put.

Table of Contents

Before You Begin	1	Available Connections	45
Overview	1	Defaults Viewer	46
System Requirements	1	Accessing the Defaults Viewer	46
Program Limits	1	Defaults Viewer Interface	47
License Agreement	2	Setting up a new Default	48
Technical Support	2	Defaults Viewer Footer buttons	49
Available Connection Types	3	Results	51
Available Connection Types	3	Member Information	51
Application Interface	5	Design Checks	51
Menus and Toolbars	5	Design Checks for Canadian Code	52
Shortcut Keys	9	Connection Design Procedures	52
Connection View	10	Column Stiffener Checks for Moment Con-	
Project Explorer	13	nections	55
Connection Properties	14	Plate Interaction for Welded Connections	56
Units	22	HSS Checks per the CIDECT Manual	56
Sign Convention	23	Canadian Code Limitations	57
Axial Load	25	Stability and Geometry Checks	58
Beam Shear	26	Erection Stability	58
Beam Moment	26	Rotational Ductility	58
Story Shear	26	Bolts Located Between Horizontal Welds	61
Graphic Display	27	Bolt Geometry Restrictions	62
3D View Controls	27	Stabilizer Plates	63
2D View Controls	28	Material Checks	64
Reports View	29	Shear Yield Strength	64
Plot Options	30	Shear Rupture Strength	64
Customizing RISACconnection	33	Plate Tension Yield	64
Preferences	33	Tension Rupture	65
(Global) Project Settings	36	Beam Flexural Rupture	67
Description	36	Beam Tension Rupture	67
Solution	37	Block Shear Strength	68
Connection Modeling Process	42	Plate Tearout	69
Creating a Project	42	Plate Flexural Yielding	71
Creating a Connection	43	Plate Flexural Rupture	72
		Plate Compression Buckling	72

Shear Tab Interaction Checks	73	Force Distribution	123
Plate Flexural Buckling	75	Column Flange Bending (Shear Connections)	125
Clip Angle Interaction Check	76	Column Flange Bending (Moment Connections)	126
Angle Leg Bending	76	Column Flexural Yielding	126
Bearing Limitation	77	Column Web Punching Shear (Shear Connections)	129
Bolt Checks	78	Column Web Axial Yielding (Shear Connections to Column Web)	129
Bolt Material Options	78	Column Web Flexural Yielding (Shear Connections to Column Web)	130
Bolt Group Eccentricity	78	Column Web Yielding (Shear Connections to Column Flange)	131
Slip Critical Considerations	80	Column Web Yielding (Moment Connections to Column Flange)	131
Bolt Shear Strength	81	Column Web Crippling (Shear Connections)	132
Bolt Tensile Strength	82	Column Web Crippling (Moment Connections)	133
Bolt Bearing Strength	89	Column Web Buckling (Moment Connections)	134
Weld Calculations	92	Column Panel Zone Shear	135
Weld Geometry	92	Column Web Out of Plane Checks	137
Base Material Strength	93	Design Checks for HSS Members	140
Elastic Weld Strength	94	HSS Limitations	140
ICR Weld Strength	97	CSA HSS Limitations	141
Non-Eccentric Fillet Weld Strength	98	HSS Punching Shear	142
PJP Weld Strength	100	Shear Tab	142
CJP Weld Strength	101	Clip Angle, End Plate	142
Weld Limitations	101	Shear Tab	143
Double-Sided Connections	103	Clip Angle, End Plate	143
Defining the Connection	103	Shear Tab	144
Limit States	105	Clip Angle, HSS T-Connection	144
Results Report	108	Through-Plate Welds	145
Skewed Connections	110	HSS Transverse Plastification	145
Geometry Input and Considerations	110	Shear Tab	146
Loading Considerations	113	Clip Angle, End Plate	147
Design Considerations	114	Shear Tab	147
Coped Beam Checks	119	Clip Angle, HSS T-Connection	148
Calculation of Snet (Net Section Modulus)	119		
Flexural Rupture Strength	119		
Local Web Buckling Strength	120		
Lateral Torsional Buckling Strength	121		
Limitations	122		
Column Connection Checks	123		

HSS Flexural Plastification	149	Reduced Beam Section (RBS) Moment Connection	178
Shear Tab	149	Welded Un-reinforced Flange Welded Web (WUF-W) Moment Connection	180
Clip Angle, End Plate	150	Bolted Stiffened/Un-stiffened Extended End Plate (BEEP) Moment Connection	181
Shear Tab	150	Bolted Flange Plate (BFP) Moment Connection	181
Clip Angle, HSS T-Connection	151	Ordinary Moment Frame (OMF) Connections	181
HSS Sidewall Local Axial Yielding	152	Seismic Moment Connection Checks	182
Clip Angle, HSS T-Connection	152	Seismic Moment Connection DXF Output ..	185
HSS Sidewall Local Flexural Yielding	153	Vertical Brace Connections	186
Clip Angle, End Plate	153	Limitations	186
Clip Angle, HSS T-Connection	153	Diagonal Brace Connection	190
Branch Axial Yield	154	Chevron Brace Connection	195
HSS T-Connection	154	General Assumptions for Extended Shear Tab Connections	199
Branch Flexural Yield	155	Knee Brace (Kicker Brace) Connection	200
HSS T-Connection	155	Gusset Plate Design	202
HSS Combined Interaction	155	Wide Flange Brace Members with Clip Angle Gusset Connections	204
HSS Beam to Column Moment Connection ..	156	Connection Eccentricity	207
Welds to Face of HSS	157	Seismic Vertical Brace Connections	208
Knife Plate or End Tee Unbraced Lengths ..	157	How to Create a Seismic Vertical Brace Connection	208
Column Stress Interaction Parameter, Q_f	158	Seismic Input Values	211
Column Buckling Reduction Factor, χ	158	Limitations- Seismic Vertical Braces	212
Design Checks for Moment Connections	159	Seismic Brace Design Force Calculations ..	212
Required Flange Force	159	OCBF Connection Strength	217
End Plate Moment Checks	159	SCBF Connection Strength	217
Axial Force in Moment Connections	165	Additional Considerations of Seismic Brace Force Distribution	218
Moment Connections with Column Stiffeners	165	Seismic Vertical Brace Checks	221
Moment Connections into a Column Web (Weak Axis)	166	Seismic Detailing DXF Output	224
Continuous Beam over Column Moment Connection	169	Base Plate Connections	225
Stiffener Checks for Moment Connections ...	170	How to Create a Base Plate Connection	225
Transverse Stiffeners	170	Limitations- Base Plate Connections	227
Doubler Plates	171	Input Properties	228
Seismic Moment Connections	174		
How to Create a Seismic Moment Connection	174		
Seismic Moment Connection Input Values ..	178		
Seismic Moment Connection Limitations	178		

Design Methodology	237	Workflow Diagrams	280
Base Plate Design Checks	239	DXF Export	282
Anchorage Design Checks	245	Exporting DXF Files	282
Additional Brace to Base Plate Design Checks	247	Printing	284
RISAFloor and RISA-3D Integration	248	Print Current View	284
Connection Grouping	248	Report Creation Wizard	284
Grouping Behavior	249	Technical Support	287
Loading/Load Combinations	254		
Solving Connections	255		
Viewing Results (in RISACONNECTION)	256		
Viewing Results (in RISAFloor or RISA- 3D)	257		
Round-tripping between RISAFloor/RISA- 3D and RISACONNECTION	258		
Miscellaneous	260		
Hilti PROFIS Integration	261		
Exporting to Hilti PROFIS	261		
Importing Hilti PROFIS Results	264		
Currently Supported Connections	267		
Limitations	267		
Changing Hilti PROFIS Accounts	267		
Troubleshooting	268		
Tekla Structures Integration	270		
Connection Grouping	270		
Grouping Behavior	271		
Loading	273		
Solving Connections	275		
Viewing Results (in RISACONNECTION)	275		
Viewing Results (in Tekla Structures)	277		
Round-tripping between Tekla Structures and RISACONNECTION	278		
Tekla Structures Integration Procedure	279		
1. Completing the Tekla Structures Model ..	279		
2. Sending the Model to RISACONNECTION ..	279		
3. Configuring Connections and Solving in RISACONNECTION	279		
4. Connection Results Viewing in Tekla	279		

Before You Begin

Welcome to the RISACONNECTION General Reference manual. Please read this topic prior to installing the program and pay particular attention to the [License Agreement](#). If you are a first time user of RISACONNECTION it would be beneficial to browse through this manual to become familiar with the interface and connection design capabilities.

Overview

RISACONNECTION is a hot-rolled steel connection design program that allows you to design many types of connections for different hot rolled steel shapes and configurations. The program utilizes multiple graphical views with a tabular input location to make connection modeling straightforward and efficient. After configuring your connection, the program will give detailed calculations for all of the different connection failure modes complete with full calculation values that you can verify quickly and easily.

System Requirements

One of the following operating systems is required:

- Microsoft Windows 11 (64 bit only)

Software

The following additional software is required:

- Microsoft .NET Framework 4.5 or later

Internet

An internet connection is required to launch the program. The internet connection must be maintained as long as the program is open, although brief internet outages (a few minutes) do not affect the user's ability to keep the program open.

Hardware

The following hardware is required:

- 1 GHz or faster processor (x86-64)
- 1024x768 or higher monitor resolution
- 2 (or more) button mouse, mouse wheel recommended
- 1 GB of RAM
- 4 GB of hard disk space

Program Limits

Hardware Limitations

- RISACONNECTION is not a multi-threaded application, which means that it runs entirely within a single processor core. Therefore the program does not take full advantage of multi-core or multi-processor machines. This limitation affects how long it takes to solve a group or project with multiple load combinations on models integrated with RISA-3D/RISAFloor.

Demonstration Version Limitations

While you can open and solve any model, you cannot save any project or connection. Also the following limitations apply:

- Yield and rupture capacities for all steel materials are hard-coded as $F_y = 25$ ksi and $F_u = 40$ ksi.
- The welds are hard-coded to have a strength of 50 ksi.
- The allowable compressive stress of concrete for base plate connections is always set to $f'_c = 1,500$ psi.
- RISA-3D and RISAFloor models may export connections into the Demo version of RISAConnection but the other limitations (above) will still apply.
- The Demonstration Version will automatically shut down if left open for 24 continuous hours.

License Agreement

For the full license agreement, please visit: risa.com/eula

Technical Support

Complete program support is available to registered owners of RISAConnection and is included in the purchase price. This support is provided for the life of the program. The "life of the program" is defined as the time period for which that version of the program is the current version. In other words, whenever a new version of RISAConnection is released, the life of the previous version is considered to be ended. Technical support is a limited resource; first priority will always be given to those clients who are current.

See [Technical Support](#) for a list of your support options.

Available Connection Types

The following connection types are available for design in RISACONNECTION.

Available Connection Types

- **Beam to Column Shear Connections** (shear tab, clip angle, end plate).
 - Columns may be Wide Flanges, HSS tubes, or HSS pipes (shear tab only).
 - Beams may be Wide Flanges or Channels (not for end plate).
 - Double-sided connections available for clip angle shear connections into the column web.
 - Skewed connections available for Wide Flange or HSS tube columns (shear tab only)
- **Beam to Girder Shear Connections** (shear tab, clip angle, end plate).
 - Girders may only be Wide Flanges.
 - Beams may be Wide Flanges or Channels (not for end plate).
 - Double-sided connections available for clip angle shear connections into the girder web.
 - Skewed connections available for shear tabs only.
- **Shear Splices** (beam and column).
 - Columns may only be Wide Flanges.
 - Beams may only be Wide Flanges.
- **Beam to Column Flange Moment Connections** (direct weld, extended end plate, flange plates, flush end plate).
 - Direct Weld and Flange Plate moment connection columns may be Wide Flanges or HSS Rectangular Tubes.
 - Extended End Plate and Flush Plate moment connection columns may only be Wide Flanges.
 - Beams may only be Wide Flanges.
- **Beam to Column Web Moment Connections** (direct weld, flange plates).
 - Columns may only be Wide Flanges.
 - Beam may only be Wide Flanges.
- **HSS Beam to Column Moment Connection** (direct weld)
 - Columns must be HSS Rectangular or Square Tubes.
 - Beams must be HSS Rectangular or Square Tubes.
- **Beam to Column Moment Connections** (Continuous beam over column).
 - Columns may be Wide Flanges, HSS Tubes, or HSS Pipes.
 - Beams may only be Wide Flanges.
- **Moment Splices** (beam and column, direct weld, end plate, flange plate).
 - Columns may only be Wide Flanges.
 - Beams may only be Wide Flanges.
- **Vertical Brace Connections** (Chevron, Diagonal Brace, and Knee Brace).
 - Columns may be Wide Flanges, HSS Tubes, or HSS Pipes.
 - Beams may be Wide Flanges, HSS Tubes (Chevron and Knee Brace connections only), or HSS Pipes (Chevron and Knee Brace connections only).
 - Chevron and Diagonal Braces may be Wide Flanges, HSS Tubes, HSS Pipes, Channels, WTs, Double Angles, or Single Angles.
 - Knee Braces may be HSS Tubes, HSS Pipes, Channels, WTs, Double Angles, or Single Angles.
- **Single Column Base Plate Connections.**
 - Column may be a Wide Flange, Tube, or Pipe.
 - Includes anchorage design, featuring the detailed design and analysis of anchor bolts (Available in v15.0 and newer).
- **Brace to Base Plate Connections.**
 - Column may be a Wide Flange, Tube, or Pipe.
- **Brace to Column Base Plate Connections.**
 - Column may be a Wide Flange, Tube, or Pipe.
 - Brace may be HSS Tube, HSS Pipe, Single Angle, Double Angle, WTs, or Channels.

- **Truss HSS T-Connections.**
 - Chord member must be a HSS Tube.
 - Branch member must be a HSS Tube.

Application Interface







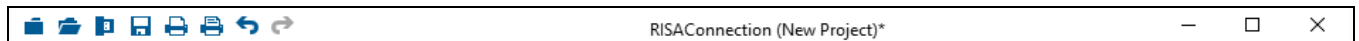



Modeling features in RISAConnection may be accessed through the ribbon toolbar, shortcut keystrokes, and the Connection Properties spreadsheet. You may use any or all of these options to interact with the software. The ribbon toolbar contains the tools required to create new models, save, print, access Global Project Settings, and the viewing options. The shortcut keys provide a fast way to access features should you use the program often enough to make them familiar to you. Finally, the Connection Properties spreadsheet contains all the user-input data to model your connection. These features are discussed in the sections below.

Menus and Toolbars

Title Bar



The bar at the top is called the title bar. The title of your project can be seen in the center of the bar, and the buttons are described below:

Button	Function
	Starts a new project
	Opens a previously created project
	Adds a connection to the current project
	Saves the current project
	Prints the current connection view
	Access the report printing options
	Undo previous changes
	Redo previous changes
—	Minimize program window
	Maximize program window
	Restore down the program window
	Close the program

Ribbon Toolbar

Just beneath the title bar is the ribbon toolbar. This toolbar is divided into tabs to combine similar features and tools. Each tab is described below.

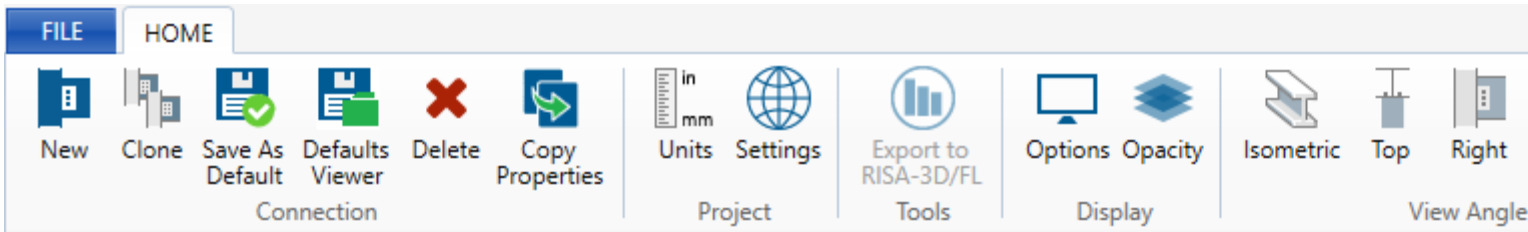

File Menu

The File menu contains the same model options as the Title bar (**New, Open, Save, Print**) with a few more. The additional functions are described below.

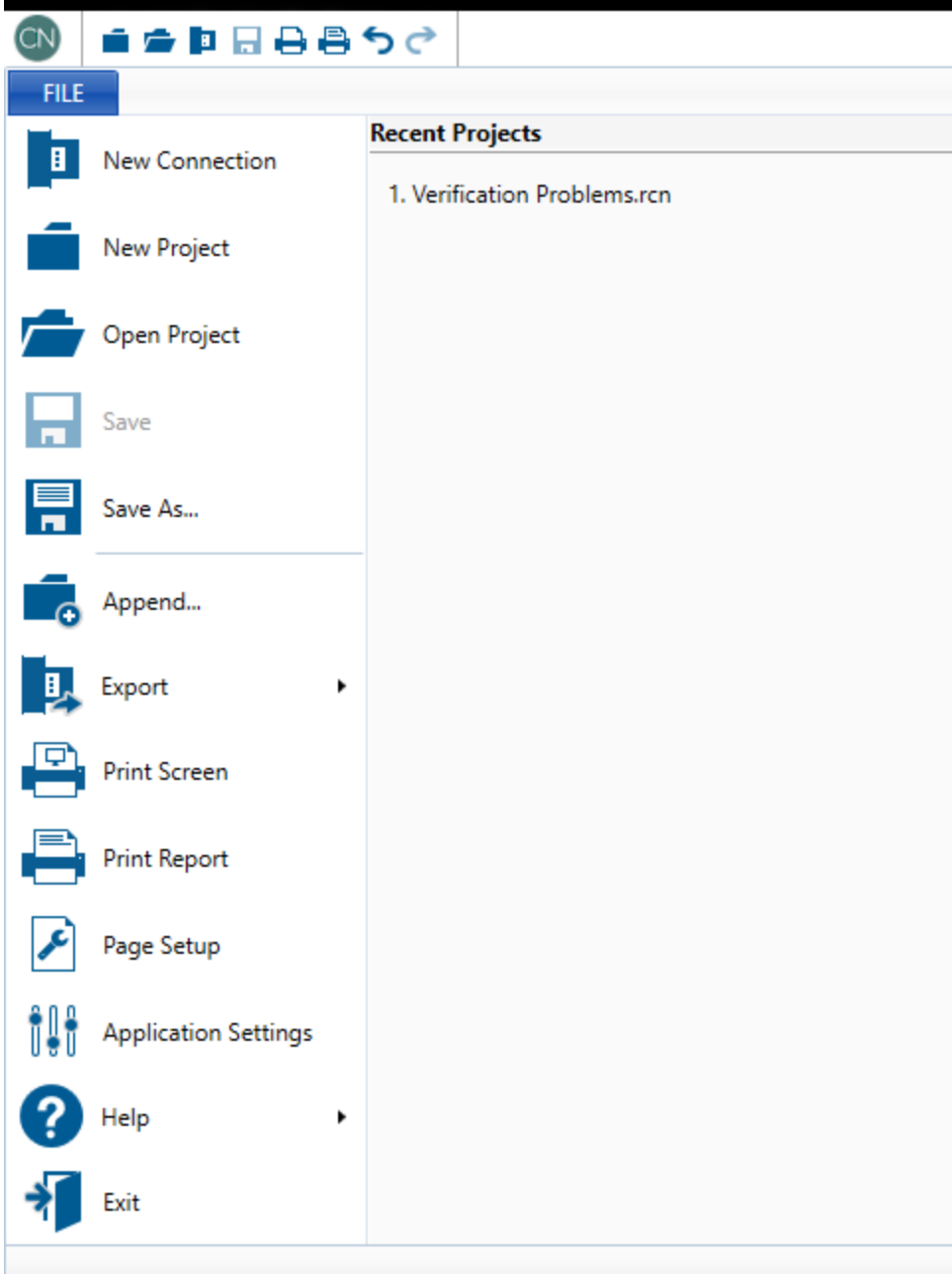



- **Save As** - Allows you to save the previously saved model with a new name, or into a new location.
- **Append** - Use this feature to combine two models into one. Open the first model, then go to **File - Append** and select the second model. The two will be merged into one model file. Be sure to rename in order to preserve the original single files!
- **Export** - RISACONNECTION has three export options:
 - **Export to RISA-3D:** If you have a RISA-3D/RISACONNECTION integrated model, you can use this option to send your RISACONNECTION results back to the RISA-3D model.
 - **Export to DXF - Single Connection:** Export the detail drawings of the currently selected connection to a [DXF file](#).
 - **Export to DXF - All Connections:** Export the detail drawings of all connections in the project to a [DXF file](#).
- **Page Setup** - Access to printing page setup options.
- **Application Settings (Preferences)** - This menu contains global solution and display options which apply to all connections in the project. From this menu, you can adjust the numerical preferences, start-up options, and the company logo to include on your printed report. See [Customizing RISACONNECTION](#) for more information.
- **Help** - Access to the following information:
 - The **RISACONNECTION Manual**.
 - The list of **Available Connection** types.
 - The **Check for Updates** feature.
 - The **About RISACONNECTION** program and licensing information.
- **Exit** - Closes the program.
- **Recent Projects** - Lists the models that you have recently created / edited with RISACONNECTION.



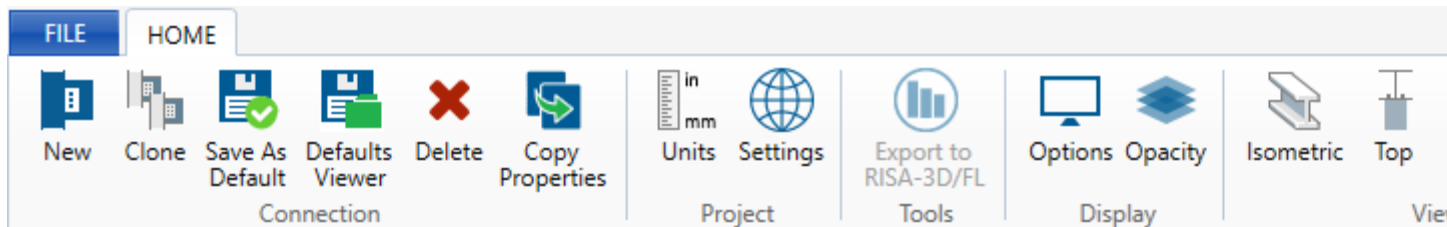







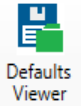

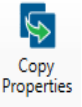
Home Menu











The Home menu contains some global buttons which effect the whole project and some buttons which are only applicable to whichever view you are in. For example, when you are in the 3D View, the Home menu will contain options for the view angle of the connection, and when you are in the 2D View, the options for toggling the loads, dimensions, and bolts become available.



The buttons are described below:

Button	Function	3D View	2D View	Reports
 New	Add a new connection to the project.	x	x	x
 Clone	Copy the selected connection.	x	x	x
 Save as Default	Save connection geometry and input as the new default for all future connections.	x	x	x

Button	Function	3D View	2D View	Reports
 Defaults Viewer	Opens the defaults viewer dialog box.	x	x	x
 Delete	Delete the selected connection.	x	x	x
 Copy Properties	Copy the properties and configurations of selected connection to other applicable connections.	x	x	x
 in mm Units	Access the Units dialog.	x	x	x
 Settings	Access the Global Parameters .	x	x	x
 Export to RISA-3D/FL	Export the connection results to RISA-3D or RISAFloor (for integrated models only).	x	x	x
 Export to TEKLA	Export the connection results to Tekla Structures (for integrated models only).	x	x	x
 Options	Access connection display options. See Graphic Display for more information.	x	x	x
 Opacity	Toggle an opaque or transparent view.	x		
 Bolts	Toggle the view of the bolts on or off.		x	
 Dimensions	Toggle the view of the dimensions on or off.		x	
 Loads	Toggle the view of the loads on or off.		x	
 Whitmore Section	Toggle the view of the Whitmore Section and unbraced length (applicable to vertical braced connections only)		x	

Button	Function	3D View	2D View	Reports
 Isometric	Snap to isometric view.	x		
 Top	Snap to top view.	x		
 Right	Snap to right view.	x		
 Front	Snap to front view.	x		
 Left	Snap to left view.	x		
 Top to Bottom	Copy the top gusset geometry to the bottom gusset (for Vertical Brace Diagonal Connections only).	x	x	x
 Bottom to Top	Copy the bottom gusset geometry to the top gusset (for Vertical Brace Diagonal Connections only).	x	x	x
 Project	Solve all connections in the project (for integrated models only).	x	x	x
 Group	Solve all connections in the group (for integrated models only).	x	x	x
 Connection	Solve just the selected connection (for integrated models only).	x	x	x
 ?	This button allows you to access the HTML5 help menu, check for updates, and view the About Connection page which contains version and licensing information.	x	x	x

Shortcut Keys

The following keys (or key combinations) can be accessed as shortcuts to help speed up your modeling.

Shortcut Key	Action
CRTL + O	Open a File

Shortcut Key	Action
CRTL + S	Save a File
F1	Access Help Menu
F2	Switch to a 2D View
F3	Switch to a 3D View

Connection View

The **Connection View** provides options for viewing both the graphical display of the connection (in 2D or 3D view) and also viewing the result output report.

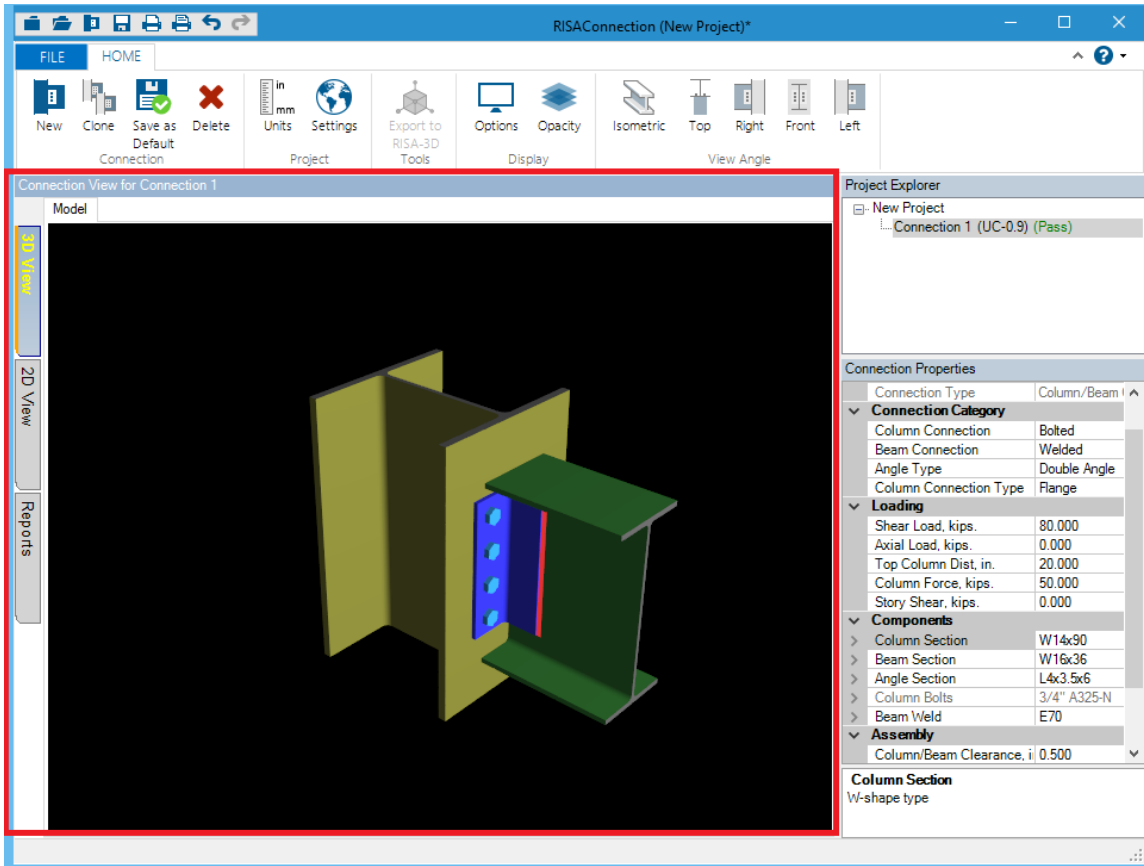

Graphical Display

The screenshot shows the RISAConnection software interface. The main window is titled "Connection View for Connection 1" and displays the LRFD Results. The interface includes a menu bar (FILE, HOME), a toolbar with icons for New, Clone, Save as, Delete, Units, Settings, Export to RISA-3D Tools, and Options. The main content area shows the RISA logo and the title "Connection 1" with the subtitle "Column/Beam Double Angle Shear Connection". Below this, there is a 3D view of the connection and a table of material properties and input data. The bottom section of the main window contains a table of limit state results.

Material Properties:

Component	Section	Grade	F_y (ksi)	F_u (ksi)
Column	W14x90	A992	50.0000	65.0000
Beam	W16x36	A992	50.0000	65.0000
Angle	L4x3.5x6	A36	36.0000	58.0000

Input Data:

Shear Load	80.0000 kips	User Input Shear Load
Axial Load	0.0000 kips	User Input Axial Force
Top Column Dist	20.0000 in	User Input Top Column Dist
Column Force	50.0000 kips	User Input Column Force
Story Shear	0.0000 kips	User Input Story Shear

Note: Unless specified, all code references are from AISC 360-10

Limit State Results Table:

Limit State	Required	Available	Unity Check	Result
Geometry Restrictions at Column				
				PASS
Beam Weld Limitations				
				PASS
Rotational Ductility, Erection Stability				
				PASS
Beam Shear Yield	80.0000 kips	140.7150 kips	0.57	PASS
Clip Angle Shear Yield	80.0000 kips	194.4000 kips	0.41	PASS
Beam Shear Rupture	80.0000 kips	137.1971 kips	0.58	PASS

The right-hand side of the interface shows the Project Explorer and Connection Properties panels. The Project Explorer shows the project structure, and the Connection Properties panel provides detailed information about the connection, including its title, type, category, loading, and components.

Results Report

3D View

This view allows you to move your connection around and view it from all sides and angles. If you click on a specific connection element in this view it will highlight in the [Connection Properties](#) section. See the [Graphic Display](#) topic for more information.

2D View

Viewing the model in 2D allows you to see each of the components of the connection, complete with dimensions, bolt holes and some assembly views.

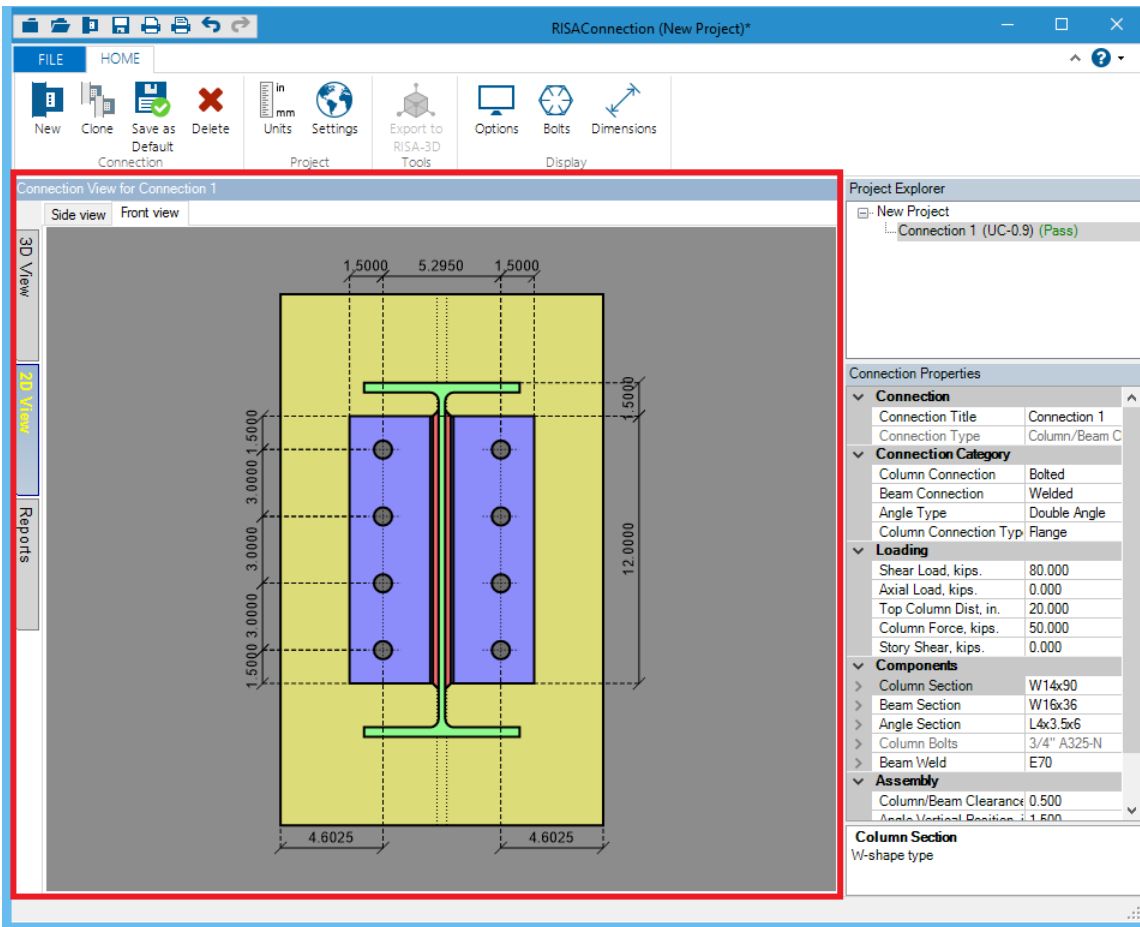

If you click on a specific connection element or dimension, that element or dimension will highlight in the [Connection Properties](#) section. See the [Graphic Display](#) topic for more information.

Certain views in the 2D view can visually show the loads applied to the connection, enhancing clarity and customization during design reviews and presentations.

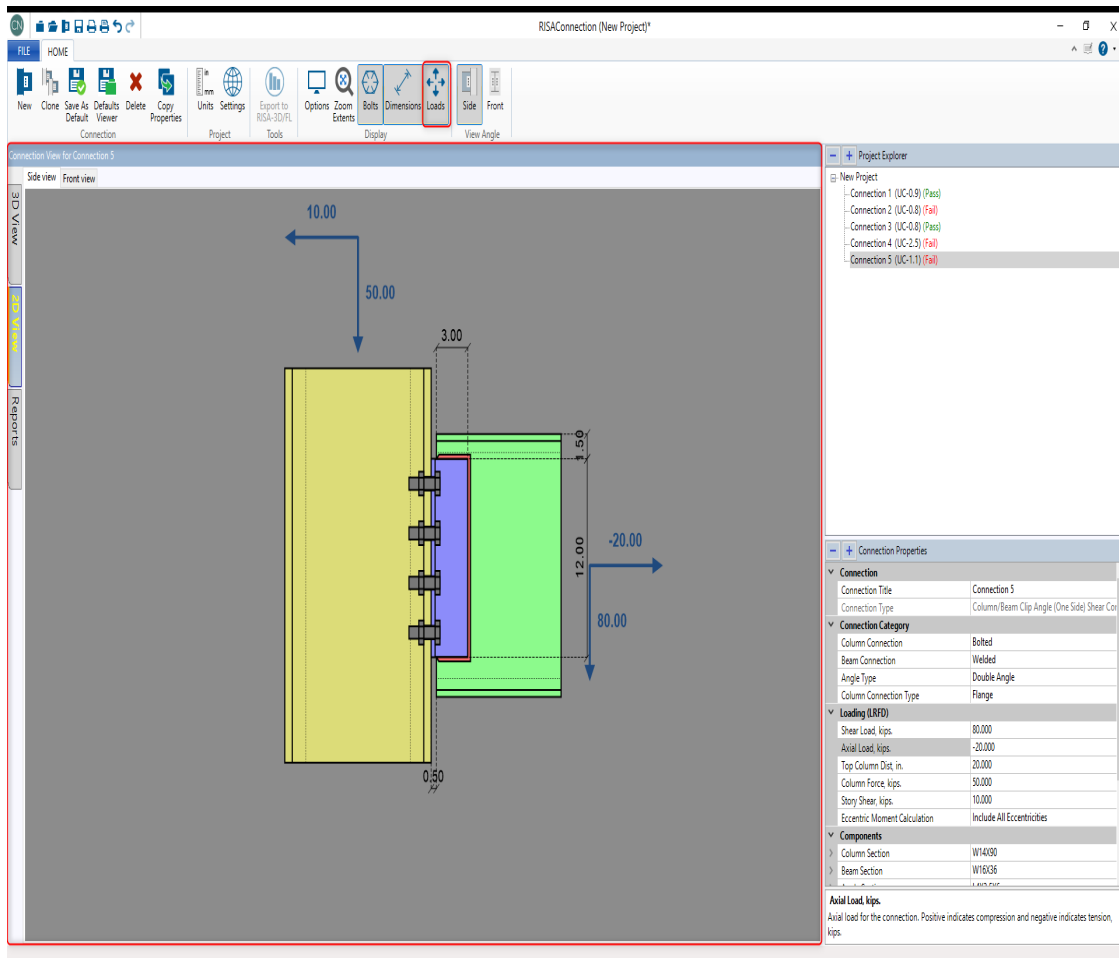

This feature can be turned on by clicking the Loads button in the Home menu as shown below.

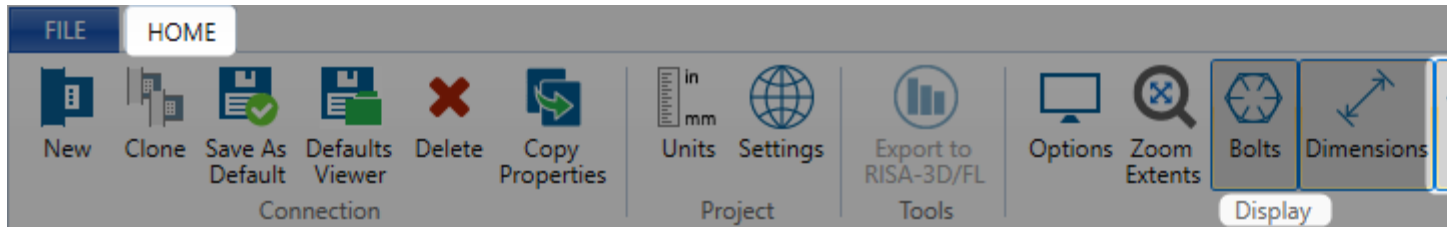

Reports

The Reports section shows all the results from the program, including component properties and design checks. See the [Graphic Display](#) topic and the design checks topics for more information.

Project Explorer

The **Project Explorer** shows the current project along with a list of all the connections in the project file.

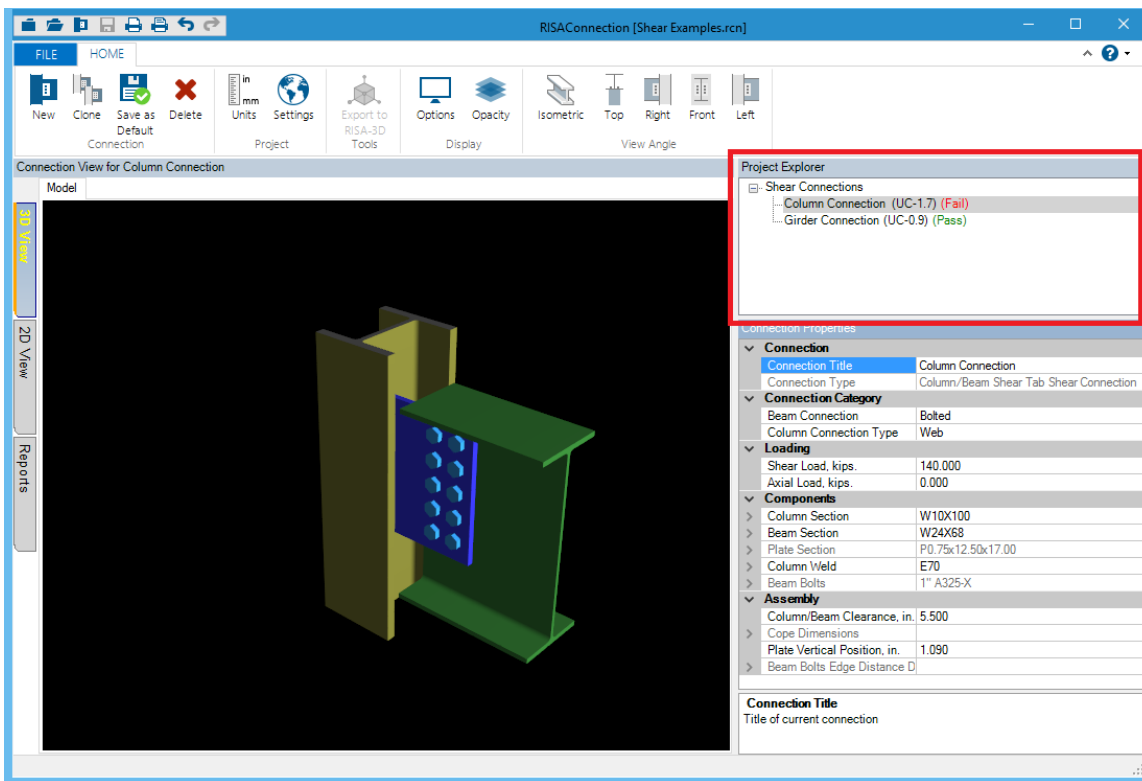

Connection Properties

The **Connection Properties** gives ability to define all of the parameters for the connection. Modifying this data automatically updates the design check calculations in standalone mode. If integrated with RISAFloor and/or RISA-3D, then you must re-solve the connection after changes.

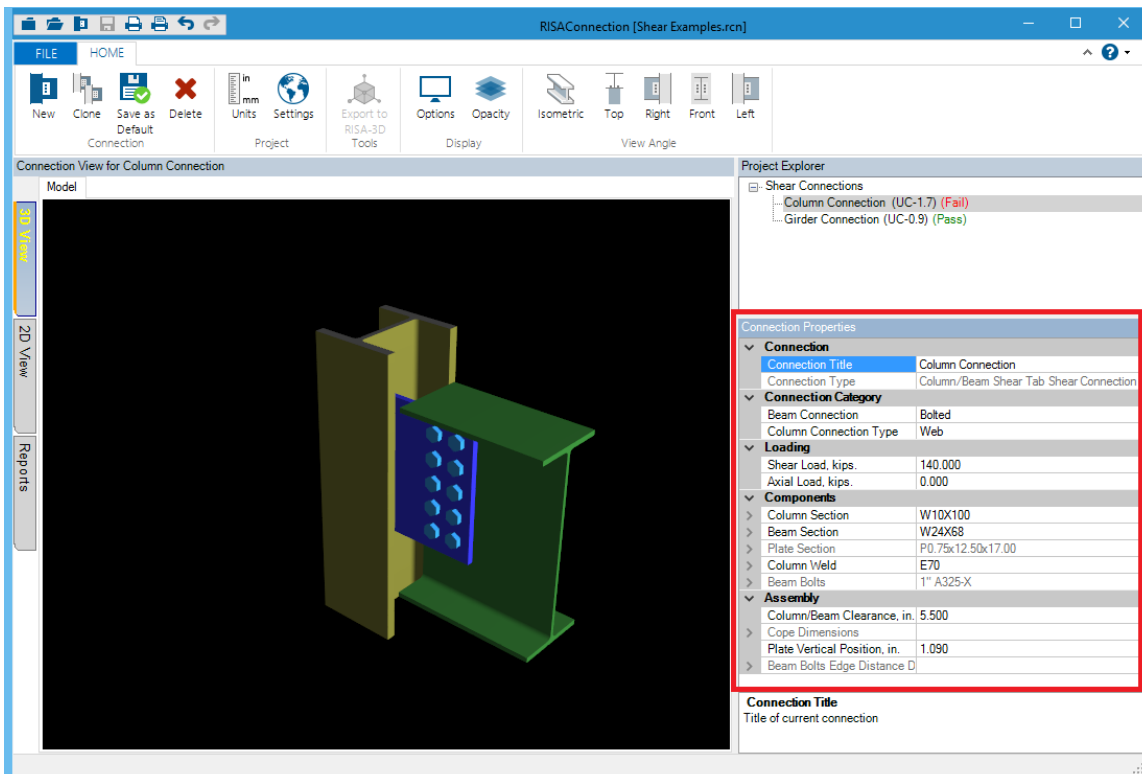

Note:

- If using RISACONNECTION integration with RISAFloor and/or RISA-3D, some of these fields are grayed out in certain scenarios. For more information on this see the [RISAFloor and RISA-3D Integration](#) topic.

Connection

The **Connection Title** allows you to give your connection a specific name. The **Connection Type** gives a quick description of the components of the connection.

Seismic Detailing

The Seismic Detailing section allows you to assign seismic parameters to your connection. This is only applicable to the following connection types:

- Column/Beam Direct Weld Moment Connection
- Column/Beam Extended End Plate Moment Connection
- Column/Beam Flange Plate Moment Connection
- Vertical Diagonal Braced Connection
- Vertical Chevron Braced Connection

For more information, see the [Seismic Detailing](#) topic.

Connection Category

The **Connection Category** allows you to define the connection type (bolted vs welded) and orientation.

Beam Connection allows you to choose a Welded or Bolted connection.

Column Connection Type will only be available when the column is a rectangular HSS tube where you have the option to connect the beam to the Wide or Narrow face of the column.

Loading

This is the location where you define the loading on your connection. For *shear* connections, you will define the **Shear Load** and the **Axial Load** (if applicable), which are simply the shear and axial demand for the connection. Positive axial loads designate compression loads, and negative axial loads designate tension loads.

Loading (LRFD)	
Shear Load, kips.	60.0000
Axial Load, kips.	0.0000
Top Column Dist, in.	20.0000
Column Force, kips.	50.0000
Story Shear, kips.	0.0000
Eccentric Moment Calculation	Ignore Eccentricity at Column

Note:

- If your axial load is less than 5% of your shear load, RISACONNECTION will assume that your axial load equals zero. This assumption is meant to help avoid an overly complicated design especially for models that are integrated with RISA-3D or RISAFloor and have just a small amount of axial load in the members.
- For information on Transfer Forces, see the topic under [Vertical Diagonal Brace connections](#).

Eccentric Moment Calculation

The **Eccentric Moment Calculation** input allows the user to control the eccentricities used to calculate the moment due to eccentricity at the connection.

- If the user selects **Include All Eccentricities**, the program will design for full moment due to eccentricity ($M_e = P \cdot e_y + V \cdot e_x$) and will calculate a bolt group eccentricity coefficient for the Beam Bolt Shear check based on the horizontal eccentricity.

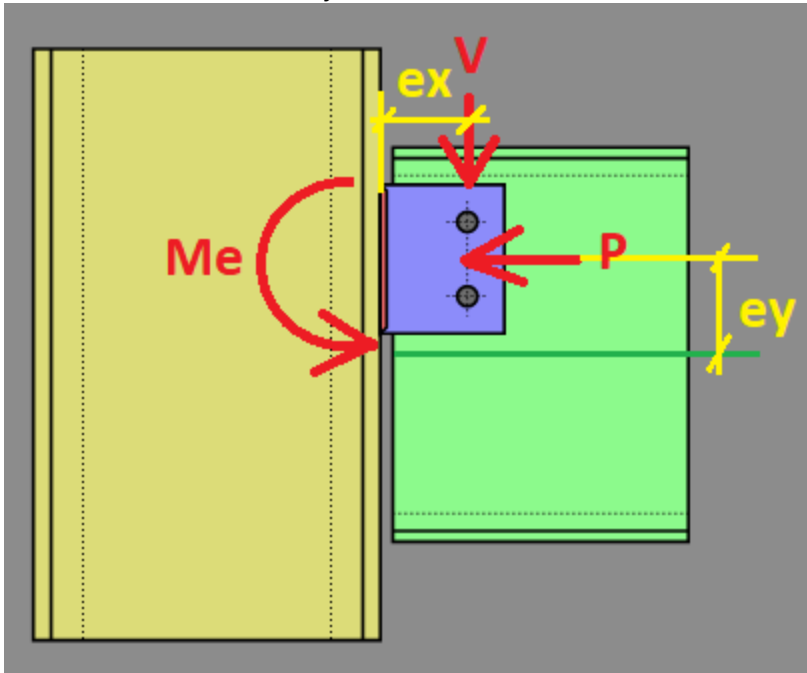

- If the user selects **Ignore Eccentricity at Column/Girder**, moment due to eccentricity (M_e) is assumed to equal zero for the Bolt Tension at Column checks (for bolted connections).
- If the user selects **Ignore Eccentricity at Beam**, the bolt group eccentricity (C) in the Bolt Shear at Beam check is assumed to always equal 1.0 (for bolted connections) or moment due to eccentricity in the Beam Weld Strength check is ignored (for welded connections).

Note:

- This was previously named **Eccentricity Consideration**, but the label was updated for clarity.

Moment Loads

For *moment* connections you will also define the **Moment Load** which is the required demand for the connection.

Loading	
Shear Load, kips.	60.0000
Axial Load, kips.	0.0000
Moment Load, kips-in.	720.0000
Top Column Dist, in.	20.0000
Column Force, kips.	50.0000
Story Shear, kips.	0.0000

Additional Loading Inputs

In addition to these, there are some extra inputs described below.

- Top Column Dist** is the distance from the top of the column to the top edge of the member framing in. This value is used for the [Column Flange Local Bending](#), [Column Web Yielding](#), [Column Web Buckling](#) and [Column](#)

[Web Crippling](#) checks. If the column is continuous past this connection, then simply input a value greater than $d_{col}/2$.

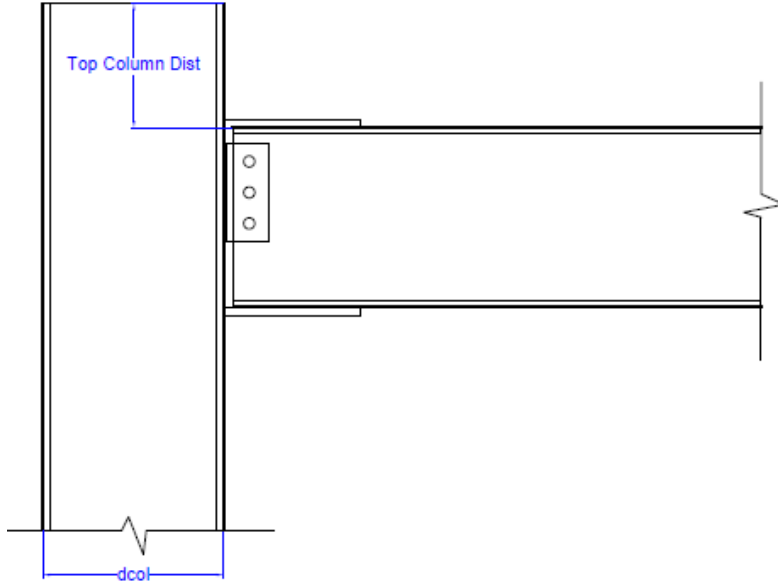

- **Column Force** is axial force in the column at the location of the connection. This is used in the [Column Panel Zone Shear](#) check.
- **Story Shear** is the shear force in the column at the location of the connection. This is used in the [Column Panel Zone Shear](#) check.

Components

The **Components** section is a location where you can input specific details about the different connection components. This is where you define member sections, materials, bolt information, weld information and other specifics. Most of these items are self-explanatory. Here are some details of the inputs.

Member Sections

In the **Shape Selection** dialog you can choose which shape Database you wish to use. This allows access to all of the RISA foreign shapes databases. Note that RISACONNECTION will NOT read in shapes from the AISC_BACKUP database.

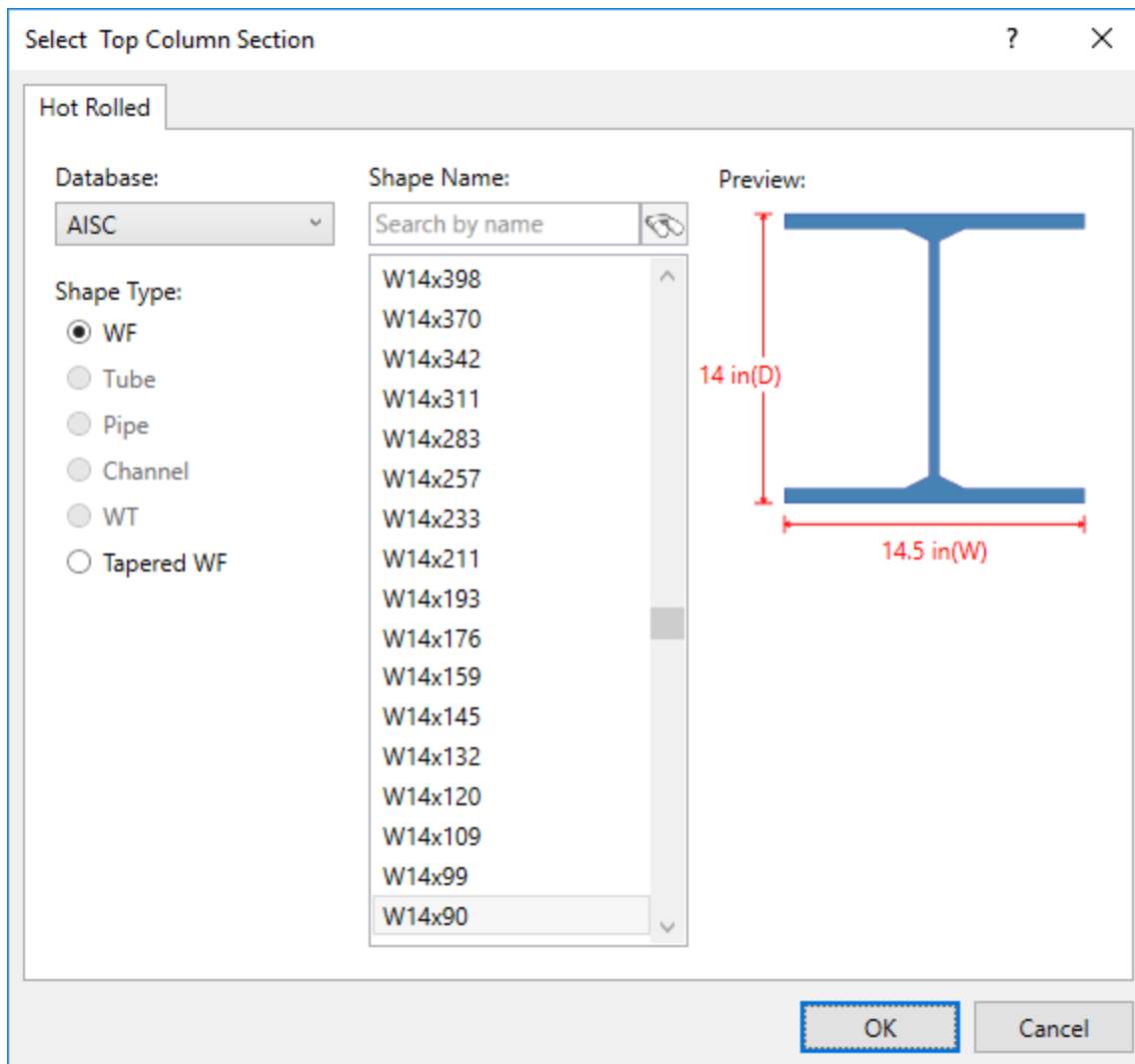

- The available Shape Types update depending on the connection and the member.

Channel Shapes

Channel members are available to be used as beam and brace members in the shear connections. Channel shapes are not currently available for moment connection members. When a channel shape is selected, the connector will always be attached to the back (web) of the channel section.

Note:

- Due to the limited cross-sectional information in the shape database, RISACONNECTION will assume flat plate sections per the published dimensions:

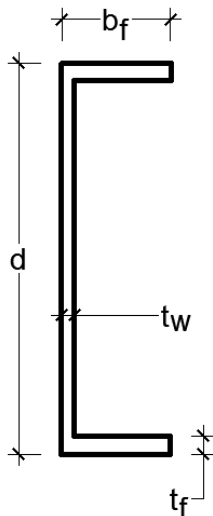

Tapered Wide Flange Shapes

RISACONNECTION will allow you to select a tapered WF shape for some members in some connections. Please see below for a list of available members.

Limitations:

- If you select a Tapered WF, you will also be required to designate which end is connected to the connection.

Components	
Column Section	Tap Column 1
Material	A992
Connected End	J End
Hole Type	STD

- RISACONNECTION will use the cross-sectional properties from the end selected in the design calculations and treat the member as though it was a prismatic (non-tapered) section.
- RISACONNECTION will make no attempt to render the tapered shape.
- Currently only doubly-symmetric (no unequal flanges) tapered WF shapes are available for use within RISACONNECTION.
- Since Tapered WF shapes are assumed to be built up (welded) plate girders, RISACONNECTION will use the following assumptions for the design calculations:

$$k_{des} = t_{flange}$$

$$k_{det} = t_{flange}$$

$$k_1 = 0.5 * t_{web}$$

$$k = t_{flange}$$

Double Clip Angles

When clip angle connections are not symmetric, the leg orientation will be specified as:

Angle Orientation	Explanation
LLS	Long Leg Supported (or Short Legs Back to Back)
SLS	Short Leg Supported (or Long Legs Back to Back)

Hole Types

The following table shows the different types of available hole types:

Hole Type	Explanation
STD	Standard holes
OVS	Oversize holes
XOVS	Extra Oversize Holes (applicable to Base Plates only (per AISC 360-10 Table C-J9.1))
SSLH	Short-slotted holes with the long dimension horizontal.
SSLV	Short-slotted holes with the long dimension vertical.
LSLH	Long-slotted holes with the long dimension horizontal.
LSLV	Long-slotted holes with the long dimension vertical.

- See Table J3.3 of the AISC 360-05 for the nominal hole dimensions for both imperial and metric units unless noted differently above.

Slip Critical

- If you have a slip-critical design consideration, choose which type of faying surface you have (Class A or Class B). This will define the mean slip coefficient for Eq J3-4 from the AISC 360-05 specification.
- The Hole Types used for slip critical connections define whether the connection should be designed for slip as a serviceability limit state or a strength limit state. Connections with standard holes and transverse slotted holes are designed for slip as a serviceability limit state. Connections with oversized holes and vertical slotted holes are designed for slip as a strength limit state.

Assembly

The **Assembly** section is where you define other required dimensions such as: coping dimensions, edge distances, clearances, etc. Many of these values can be changed manually. Some of these values have maximum values that if you exceed that value we will use the maximum value. Other values are grayed out, meaning their value is dependent on other dimensional properties of the connection.

Notice that for all of the input, a more detailed explanation will be displayed in the display at the lower right corner of the screen.

Connection Properties	
▼ Connection	
Connection Title	Flange
Connection Type	Column/Beam Flange Plate Moment Connection
▼ Seismic Detailing	
Seismic System	None
▼ Connection Category	
Beam Connection	Bolted
Beam Flange Connection	Bolted
Transverse Stiffeners	No
Web Doublers	No
▼ Loading	
Shear Load, kips.	48.000
Axial Load, kips.	0.000
Moment Load, kips-ft.	320.000
Top Column Dist, in.	0.000
Column Force, kips.	0.000
Story Shear, kips.	0.000
▼ Components	
> Column Section	W12X136
> Beam Section	W21X68
> Shear Plate Section	P0.38x4.00x12.00
> Moment Plate Section	P0.88x8.00x15.75
> Column Weld	E70
> Beam Bolts	3/4" A325-N
> Moment Column Weld	E70
> Moment Beam Bolts	1" A325-N
▼ Assembly	
Column/Beam Clearance, in.	0.500
Plate Vertical Position, in.	1.190
> Beam Bolts Edge Distance Dir	
> Moment Bolts Edge Distance	
Moment Bolts Gage, in.	4.500

Axial Load, kips.
Axial load for the connection. Positive indicates compression and negative indicates tension, kips.

Try clicking around in the various input cells to see this display change.

Here are some specific assembly details.

- **Beam Vert Offset** (for Girder/Beam connections): This value is positive if the beam is set downward from the girder and is negative if the beam is set upward from the girder.
- **Angle Vertical Position** (for Girder/Beam connections): This value is not allowed to be smaller than the top coped depth of the beam. There is no check that the angle doesn't foul the bottom flange.
- **Auto-Update Connections** (for Vertical Brace Connections): This option (Yes or No) tells the program whether you wish to completely reconfigure the Gusset to Beam and the Gusset to Column (diagonal brace connection only) connections. By stating **Yes** the program will completely optimize your connection AND reset everything for that connection each time you make a geometry change. By stating **No** the program will not modify these connections. Thus, if you are starting from scratch and just inputting the initial geometry information, keep this option on **Yes** to get optimized connections. However, once your connection is mostly laid out, switch this to **No** to save your connection information. When bringing a connection from RISA-Floor or RISA-3D this option will default to **No**. When starting a connection from scratch this option will default to **Yes**.

Units

The **Units** dialog allows the user to set the units designation for the project. You can work with Imperial units (Kips, inches, etc.) or Metric units (KN, meters, etc.), or any combination of the two. To access this dialog, simply click the Units button from the Home menu on the ribbon toolbar.

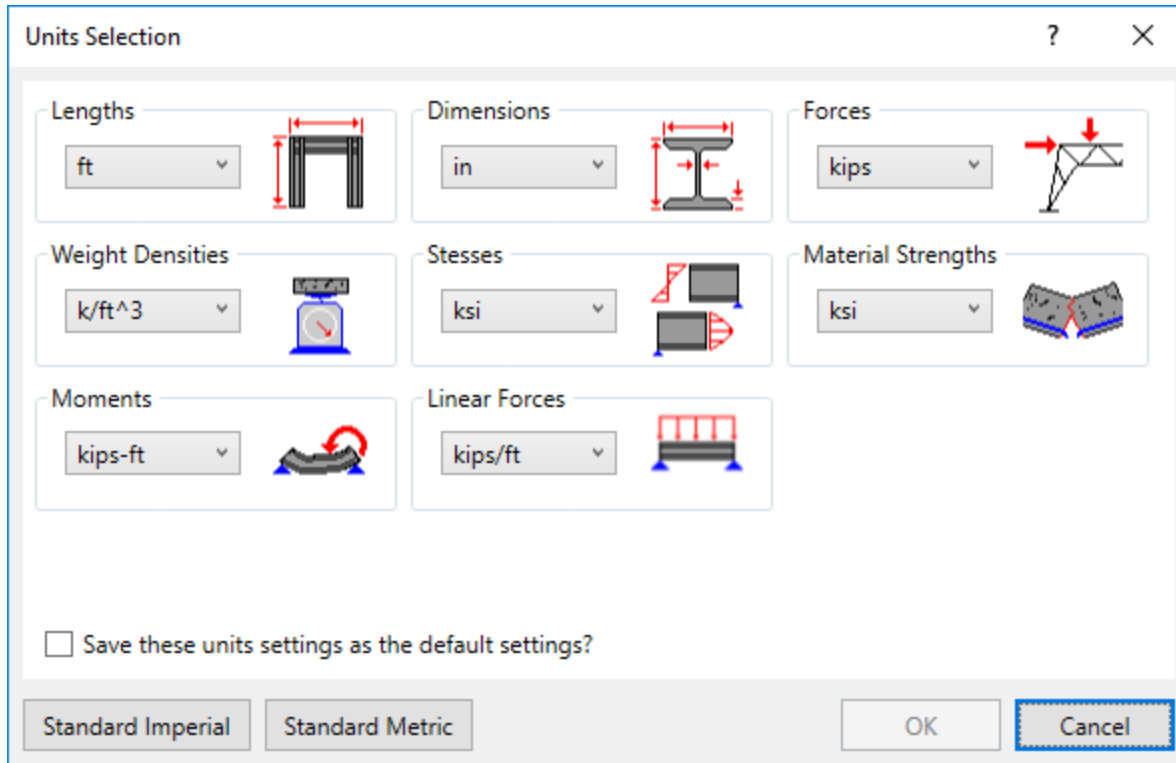
**Note:**

- Units can be changed at any time during modeling and the current units will be converted to the new units.
- Once units are set to the desired value, click the **Save As Defaults** button to make these units the default settings for any new models.

Sign Convention

RISACONNECTION uses a sign convention shown below:

Shear Connections:

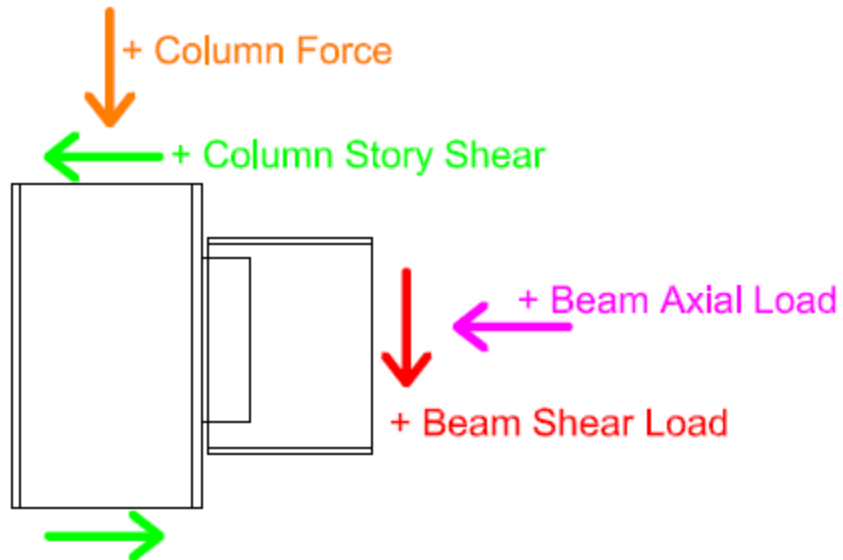

Moment Connections:

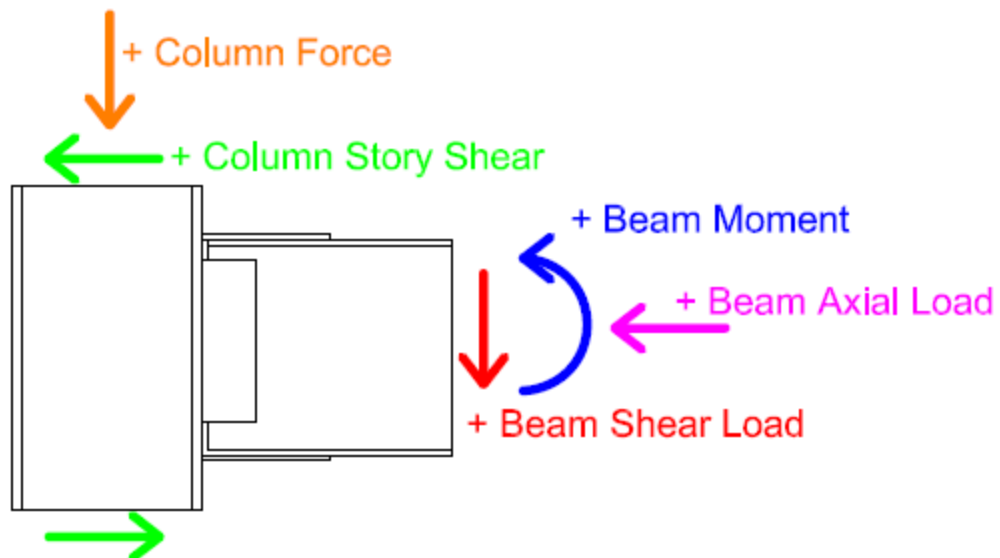

Vertical Diagonal Brace Connections:

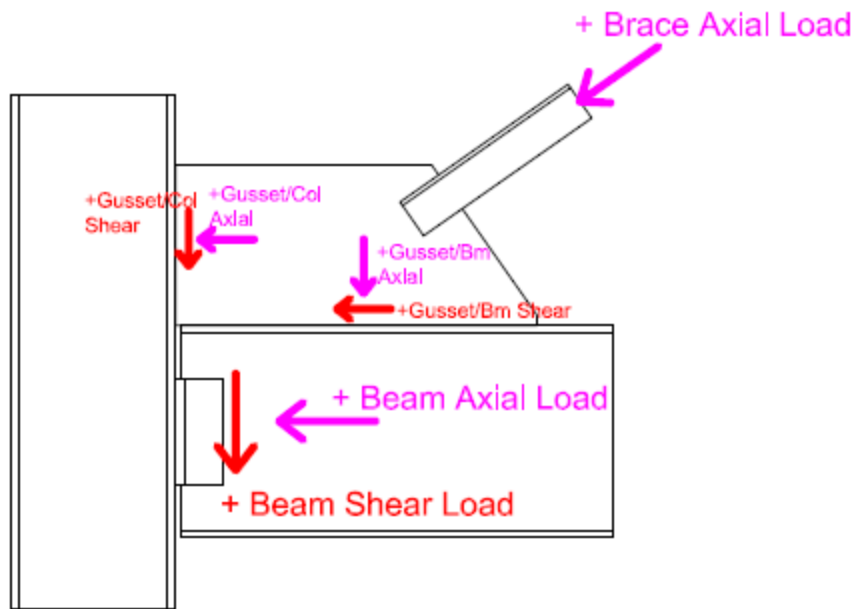

Chevron Brace Connections:

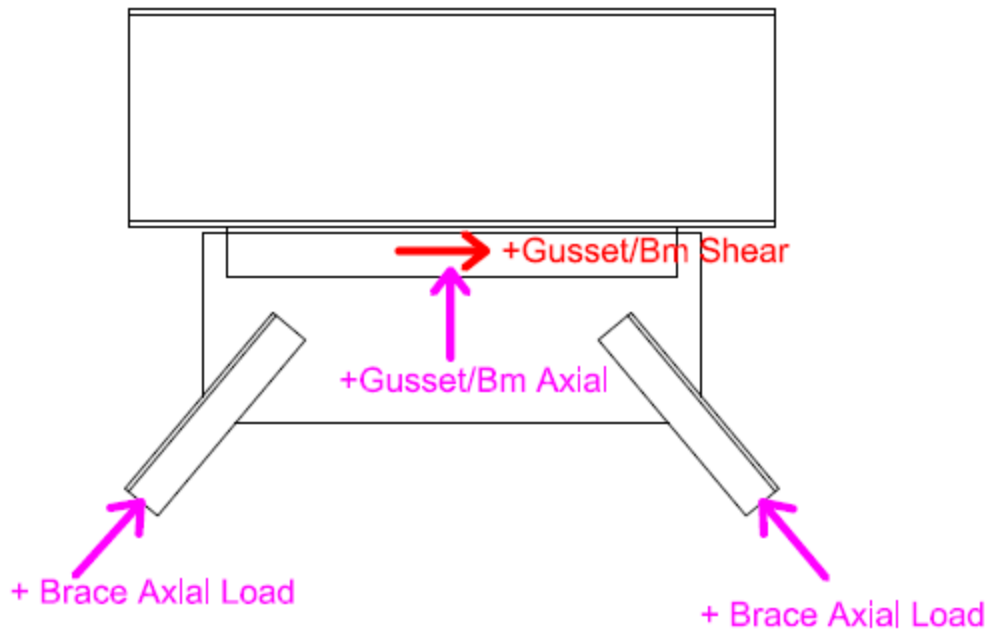

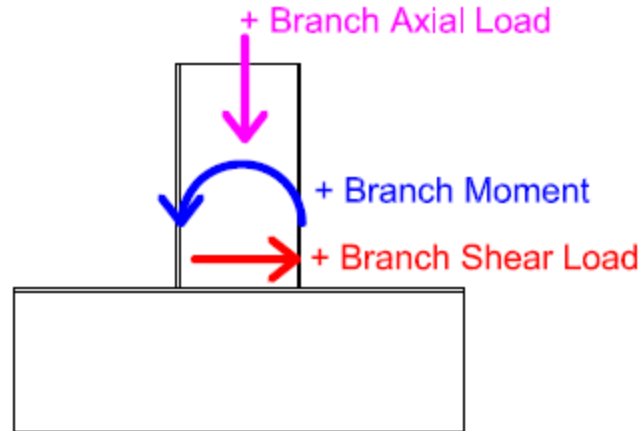
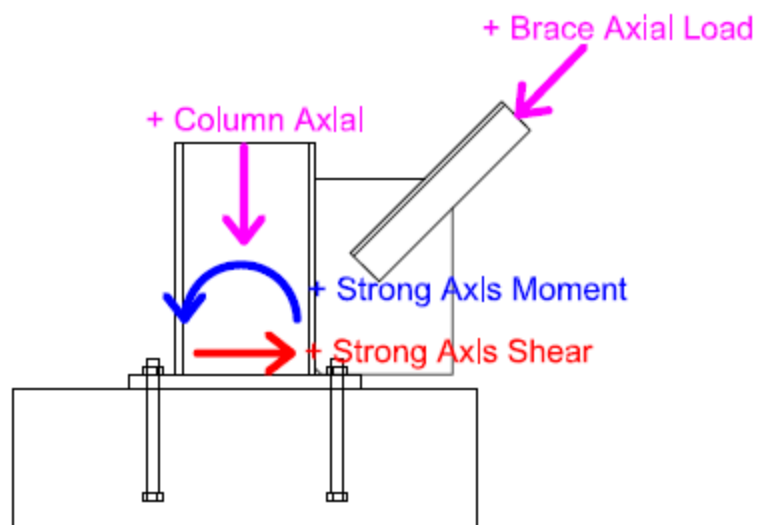
HSS T Connections:**Base Plate Connections:****Axial Load**

A positive axial load designates compression while a negative axial load designates tension. This is the same load convention used in RISA-3D and RISAFloor, so any loads imported from the integration shall stay consistent.

Note:

- If your axial load is less than 5% of your shear load, RISACONNECTION will assume that your axial load equals zero. This assumption is meant to help avoid an overly complicated design especially for models that are integrated with RISA-3D or RISAFloor and have just a small amount of axial load in the members.

Beam Shear

A downward load on the beam creates a positive shear in the connection. An upward load on the beam creates a negative shear in the connection. This is the same load convention used in RISA-3D and RISAFloor, so any loads imported from the integration shall stay consistent.

Beam Moment

The sign convention for beams with an end moment would normally result in a negative moment under gravity loads. The sign of beam moments do change the capacity calculations for the connection. In particular, the column's ability to resist the concentrated flange forces are affected by which flange is in tension or compression as well as the distance between the applied flange force and the top of the column.

Note:

- This sign convention agrees with the RISA-3D sign convention for moments, but is the opposite of RISAFloor's sign convention for moment.

Story Shear

A positive story shear will counteract the panel zone shear caused by a negative end moment in the beam..

Note:

- There are cases where the story shear will actually increase the shear demand in the panel zone. This is more likely to happen in cases where the positive bending moment caused by lateral forces is not enough to counteract the negative bending moment due to gravity forces. RISACONNECTION does take these rare cases into account.

Graphic Display

RISAConnection allows you to graphically view your connection in two- and three- dimensional views. Below, the functionality that is available within each of these views is explained.

3D View Controls

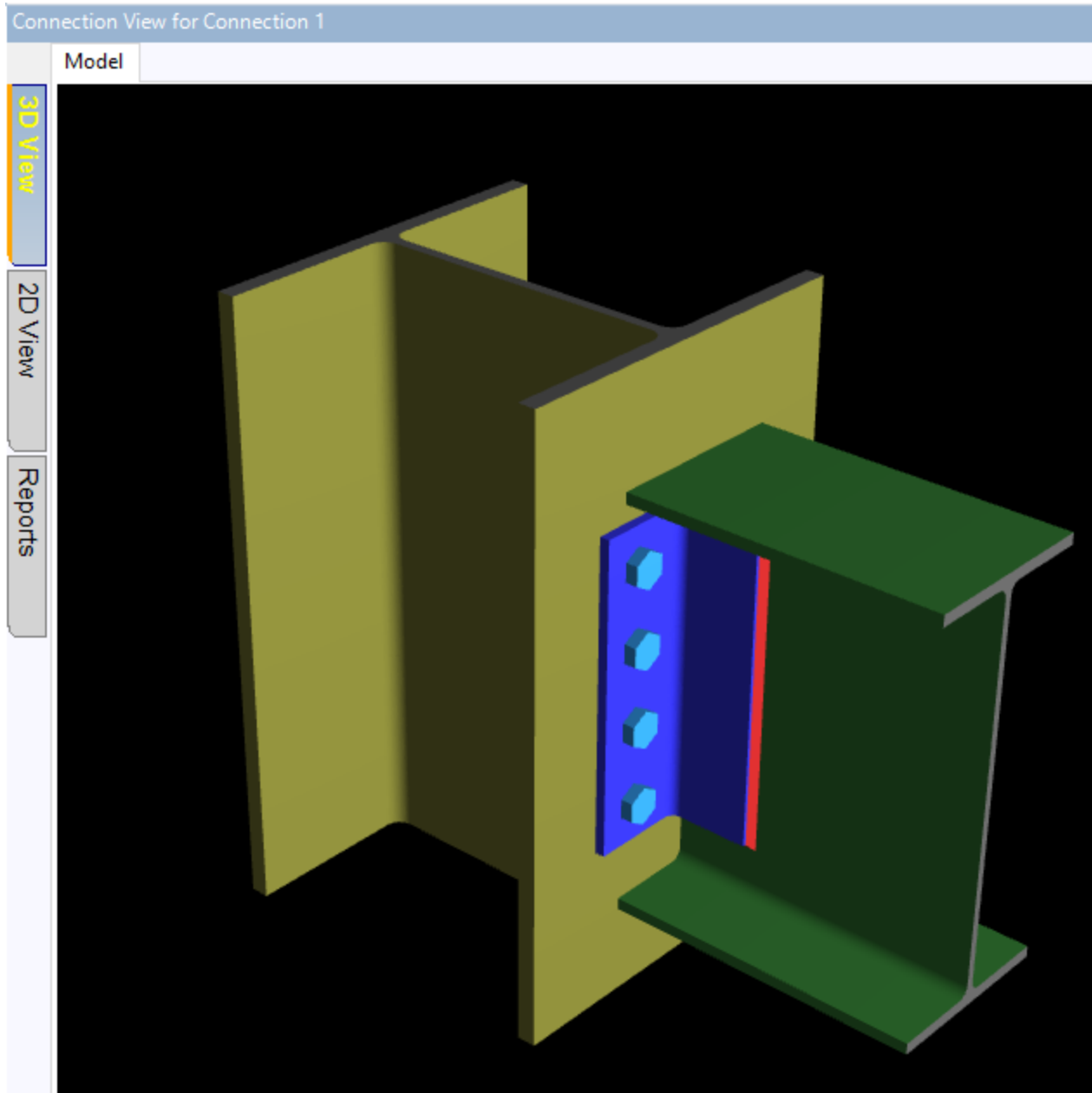

To view the 3D view, simply click the **3D View** tab in the [Connection View](#). This view allow you to see the connection from all sides by simply clicking and dragging the mouse. All of the elements in the connection are drawn/-modified in real time. Therefore, if you update a member size, or change the clip angle, you will see this update in the 3D View.

Mouse Controls

- Left-Click: If you left-click a component in the 3D view it will highlight that element in the [Connection Properties](#). This points you directly to where that component is located and provides quick access for modifying properties related to it.
- Left-Click Hold and Drag: This allows you to dynamically rotate your connection to view from all sides.
- Right-Click and Hold: This will allow you to move your connection around via panning.
- Middle Mouse Wheel Scroll: This will allow you to zoom in and out for your connection.
- Middle Mouse Wheel Click: This will snap your connection back into the initial isometric view.

2D View Controls

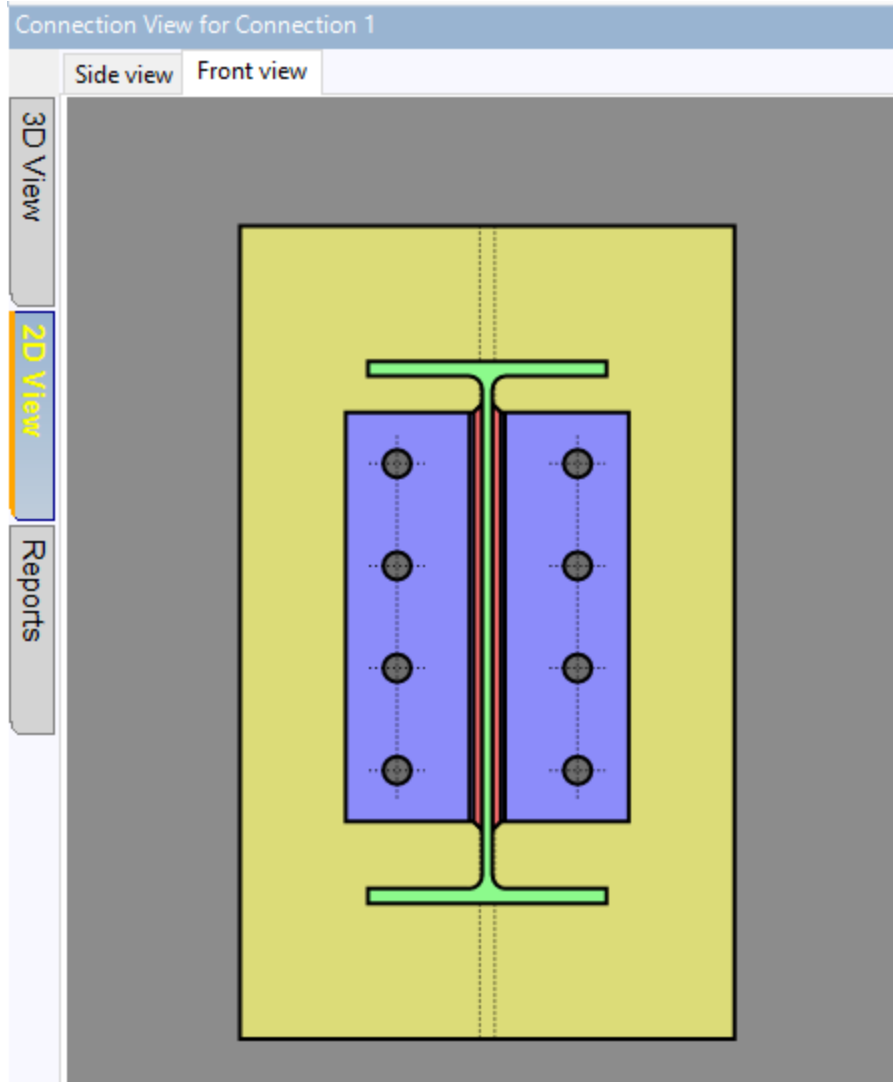

To view the 2D view, simply click the **2D View** tab in the [Connection View](#). This view allows you to use the tabs across the top of the screen to see the different connection components in various individual 2D Views. These dimensioned views allow you to double click the dimensions to show where this value is located in the [Connection Properties](#). This makes it very easy to change a dimension or property in a 2D view. There are also some component views available simply for viewing the connection assemblies.

Reports View

This view is available to show all of the output of the program. There are two main windows available: **Members** and **Results** (either **LRFD** or **ASD**, depending on the code chosen in [Global Parameters](#)). These reports are shown in real time. Therefore, whenever a property of the connection is changed, the program updates the result reports for this change.

Members

The **Members Report** view shows detailed properties of all of the components in the connection. Tabs within the report allow you to switch between these components for member properties, hole dimensions, coping and material information.

Connection View for Connection 1

LRFD Results Members Components

3D View

2D View

Reports

RISA Connection 1

Column/Beam Double Angle (One Side) Shear Connection

Members

Column Beam

Column W14x90

Material

Name	A992	Material name
F_y	50.0000 ksi	Minimum yield stress of material
F_u	65.0000 ksi	Minimum tensile stress of material
E	29000.0000 ksi	Modulus of elasticity

Member Properties

b_f	14.5000 in	Flange width
d	14.0000 in	Overall depth
t_w	0.4400 in	Web thickness
t_f	0.7100 in	Flange thickness
a	26.5000 in ²	Area
k_{des}	1.3100 in	Kdes
k_{det}	2.0000 in	Kdet
k_1	1.4400 in	K1

Hole

Hole type	Standard	
D_x	0.8125 in	Hole width
D_y	0.8125 in	Hole height
R	1	Number of rows of holes
C	4	Number of holes per row
R_s	3.0000 in	Row Spacing
C_s	3.0000 in	Column Spacing

In this example we have an end plate moment connection. Thus, we see tabs for each element in the connection, including the bolts for the connection. These are simply a presentation of properties of the connection. There are no engineering calculations used in these values.

Results

The **Results Reports** gives all of the design checks for the connection, as well as material properties for each component. These design checks are listed with the required strength, provided strength, unity check and whether the

connection passed that specific check. A red **FAILED** message will clearly alert you if you have a connection check that is not passing. In addition to a list of unity checks for each connection you can also click on the individual check to get a detailed calculation complete with explanation of each variable in that check.

Beam Shear Yield	80.0000 kips	140.7150 kips	0.57	PASS
$R_n = 0.6 * F_y * A_{gv} * C_v$		$\phi = 1.00$	(G2-1)	
F_y	50.0000 ksi	<i>Minimum yield stress of material</i>		
A_{gv}	4.6905 in ²	<i>Gross area subject to shear</i>		
C_v	1.0000	<i>Web shear coefficient (G2-2)</i>		
ϕR_n	140.7150 kips	<i>Shear yield strength</i>		

For more information/details on a specific design calculation, please see the specific check topic in the Help menu.

Plot Options

Plot Options settings provide both 2D and 3D viewing options as well as text size for the user interface and the printed reports.

3D View Tab

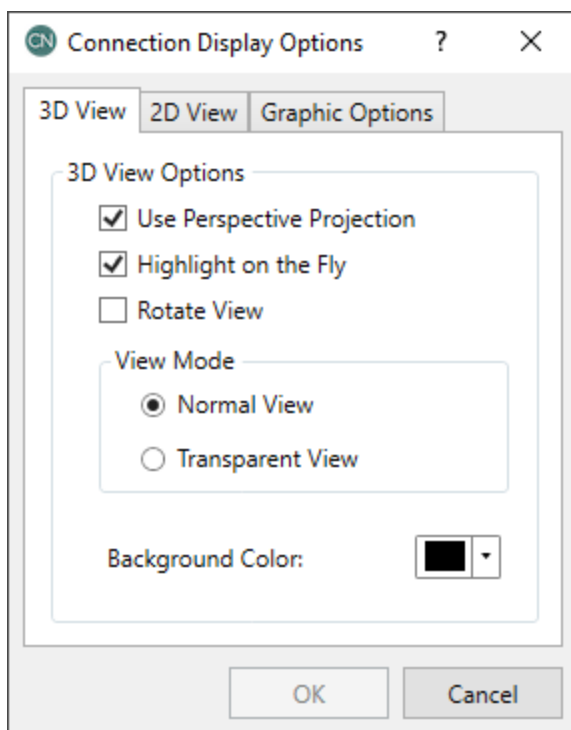

- **Use Perspective Projection** - This option puts the connection into an architectural perspective view. Pressing the "Del" key while in the Model View will toggle this option on/off.
- **Rotate View** - This animates the connection view for graphical purposes.
- **View Mode** - This gives a normal rendered view versus a transparent type view.
- **Highlight on the Fly** - With this check-box if you scroll over the connection it will highlight the specific part of the connection you are scrolling over.

2D View Tab

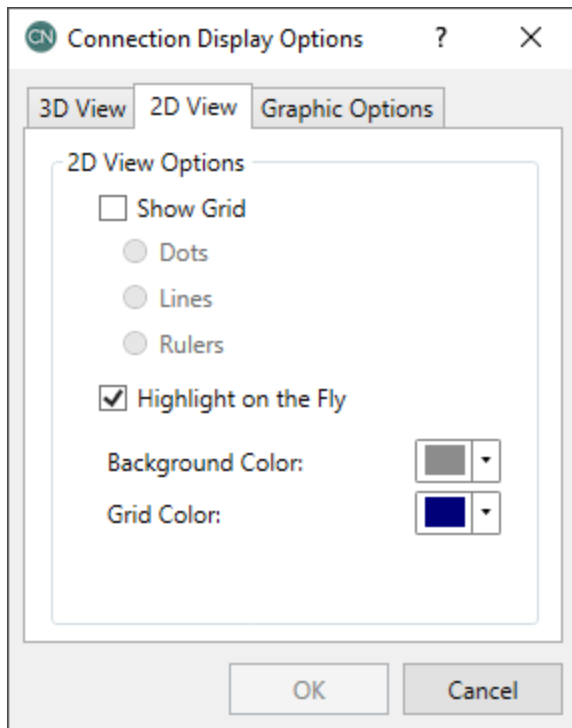

- **Show Grid** - This selection gives an option for how you want to view the background of the two-dimensional view.
- **Highlight on the Fly**- With this check-box if you scroll over the connection it will highlight the specific part of the connection you are scrolling over.

Graphic Options

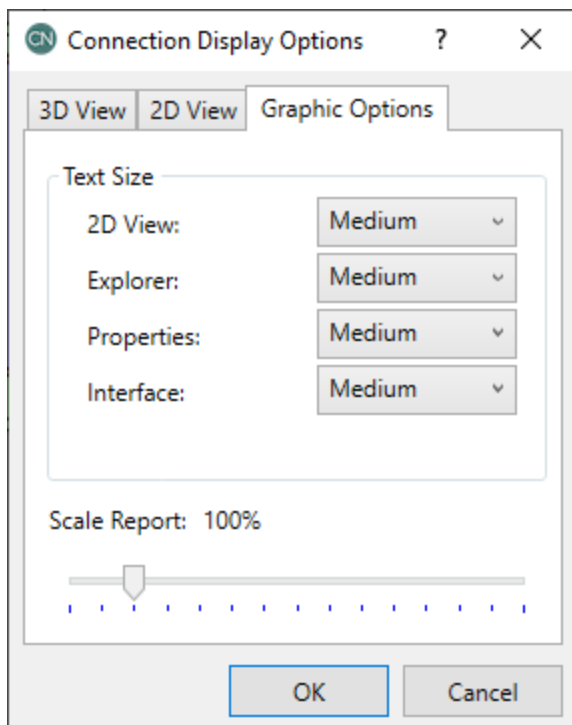

- **Text Size** - This selection gives an option to adjust the text size in the user interface.
- **Scale Report**- This slider adjusts the scaling of the text and images within the calculation reports in the "Reports" tab for each connection.

Customizing RISAConnection

You may customize several of the default parameters, and Preference options in RISAConnection. In this way you can modify the program so that it best suits you and your work processes. The **Preferences** option on the **Tools** menu provides you control over the behavior of the software. All customization may be defined or redefined at any time.

Preferences

Preferences options may be accessed by selecting **Preferences** from the **Tools** menu and are divided into the sections described below.

General Tab

The **General** tab of the **Preferences** dialog contains options that are generally straightforward and can be easily set to customize the program with every new model you create.

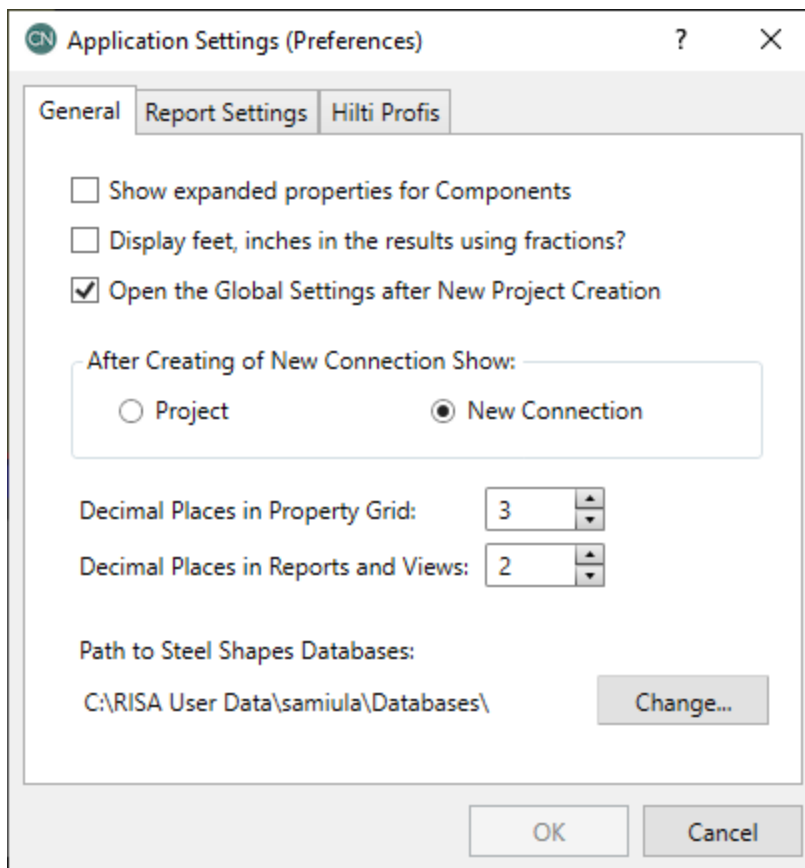

- The **Show Expanded Properties for Components** checkbox allows the user the option to expand the component information in the [Connection Properties](#) input. If this box is checked, the **Components** section of **Connection Properties** will expand to show all the section properties of your selected element (Column, Beam, Plate, etc.). If not checked, this section will condense down to just the editable properties (shape, material, etc.).
- The **Display Feet, Inches in the Results Using Fractions** checkbox allows the user control over the display of the results. If this is checked, results will display in fraction format. If it is unchecked, then they will be displayed in decimal format.

- The **Open Global Parameters After New Project Creation** checkbox controls whether or not the [Global Parameters](#) dialog box is automatically displayed to you when you start a new Project file. If this is left unchecked, then this dialog will not automatically open when you start a new model.
- The **New Connection** options allow the user to set what is displayed to you after a new Project is created. You can choose to show the entire **Project** (the main window will display thumbnails of each Connection that you have created) or automatically create a **New Connection** for you which you can then build into your Project.
- The **Decimal Places** entries allow the user control over the number of decimals that are shown in the **Property Grid** ([Connection Properties](#) spreadsheet) and the dimension values shown in the **Reports and Views**.
- The **Path to Steel Shapes Databases** shows where the program is looking for the shapes databases that it reads into the program. If your databases are not located in this path, you must either change the patch or move the databases to this directory.

Report Logo Tab

The **Report Logo** tab of the **Preferences** dialog contains options for the user to upload a company logo to include with the printed output. This image will then be displayed at the top of the design report.

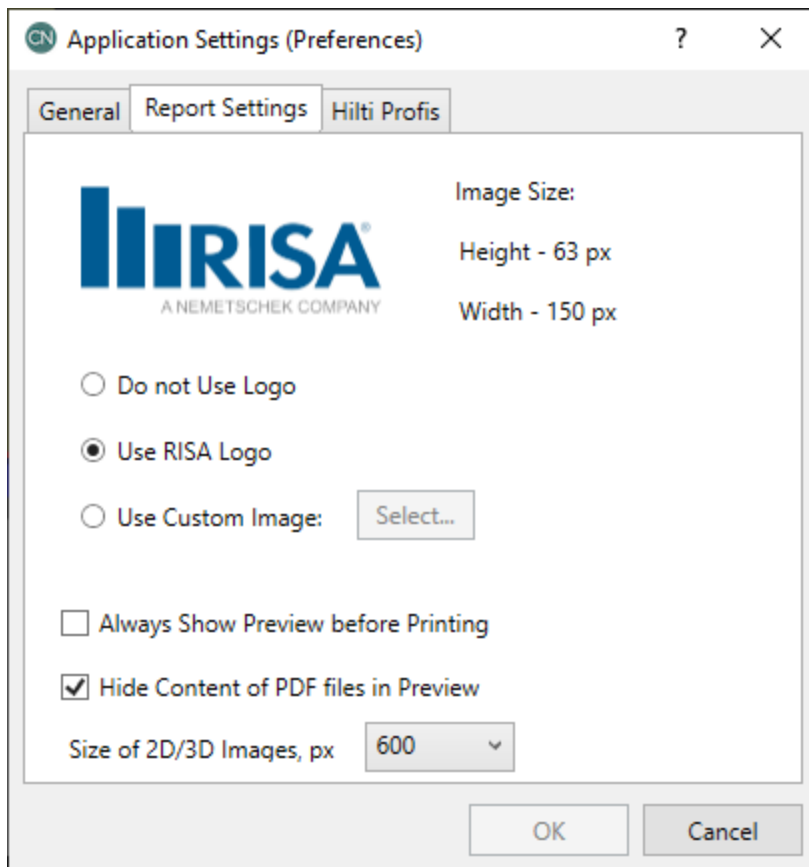

- The **Do not Use Logo** selection leaves the logo display blank.
- The **Use RISA Logo** selection uses the RISA logo for display on the report, both within the program and on the printed report.
- The **Use Custom Image** allows you to select your own custom logo to display on the report, both within the program and on the printed report.
- The **Always Show Preview before Printing** check-box allows the user to include a Print Preview within the Report Printing dialog.
- The **Hide Content of PDF files in Preview** check-box allows the user to hide the additional PDFs in the Report Printing Print Preview (this helps display the preview quicker).

- The **Size of the 2D/3D Images** menu allows the user to adjust the size of the images included in the printed report.

Hilti Profis Tab

The **Hilti Profis** tab of the **Preferences** dialog allows users to designate the directory for saving Hilti Profis calculation reports. This setting ensures that anchorage analysis results exported from Hilti Profis are stored in the specified user-defined location.

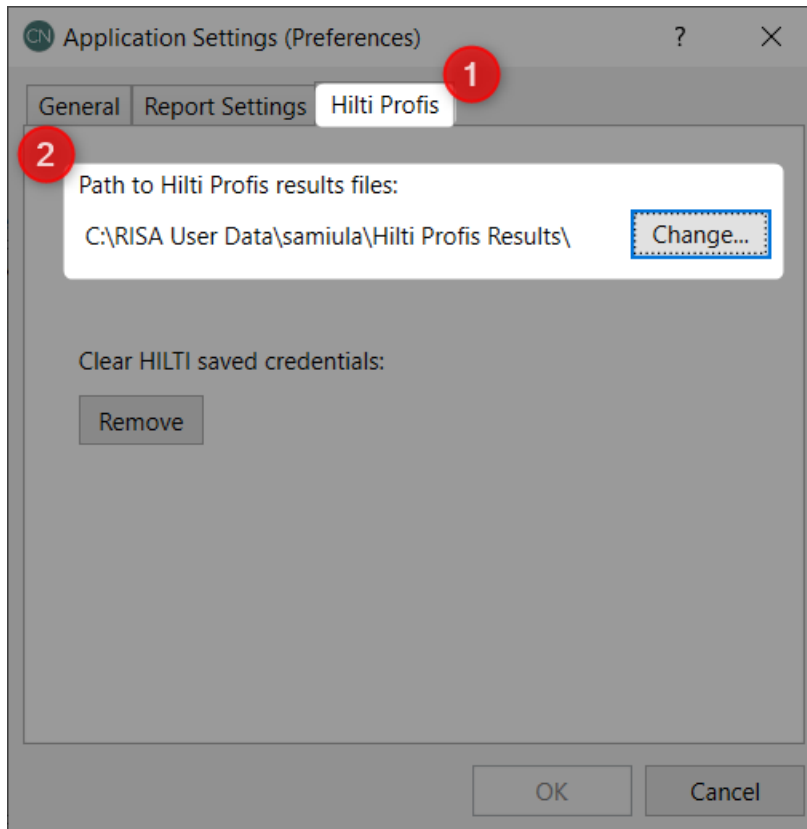

(Global) Project Settings

The (Global) Project Settings dialog is used to define information that influences the entire model and its solution in an overall (global) manner, including all the connections within a project.



To access the **(Global) Project Settings** dialog, click on the **Settings** icon from the Window toolbar.

Description

(Global) Project Settings

Description Solution

Company: RISA Tech, Inc.

Designer: CM

Project title: Verification Problems

Job number:

Notes:

Save As Defaults

OK Cancel

The entries under the **Description** tab are used to enter descriptive information such as a Title for the current project, the Name of the designer and a Job Number.

Solution

(Global) Project Settings

Description Solution

Design Code

Hot Rolled Steel AISC 15th (360-16): LRFD

Concrete ACI 318-19 (22)

Bolt Group Analysis Method

Center of Rotation Elastic

Weld Analysis Method

Center of Rotation Elastic

Consider Bolt Hole Deformation Full Shear Ecc. Considered

Check Weld Filler Metal Matching PZ Deform. Considered

Check Rotational Ductility Check Weld Base Mat. Thick

Include AISC 15th Out of Plane Web Checks

Reduce avail. bolt strength by prying effects factor Q

Display r_0 and r_u calculations for welds

Save As Defaults

OK Cancel

The **Solution** tab contains options which affect how the connections in the current project will be analyzed / designed.

Design Code

For steel connections, you may select from *AISC 360-22 (16th Edition)*, *AISC 360-16 (15th Edition)*, *AISC 360-10 (14th Edition)*, *AISC 360-05 (13th Edition)*, *CSA S16-09*, *CSA S16-14*, or *CSA S16-19*, with both ASD and LRFD design methods available for AISC codes.

For concrete connections, the options include *ACI 318-19* and *ACI 318-19 (22)*. Concrete design adheres strictly to strength design principles.

Note:

- If working in an integrated model with RISAFloor and/or RISA-3D, the **Design Method** will be grayed out and based on the settings from the RISAFloor or RISA-3D model.
- When entering loads in to the **Loading** input, be sure that they include the appropriate factors for the design method chosen.

- Some design checks also reference the additional design material provided by the *AISC Design Manual* and/or *Design Guides*.
- Once the Design Code (an other analysis options) are set to the desired value, click the **Save As Defaults** button to make these the default settings for any new models.

Bolt Group Analysis Method

The design of bolt groups with eccentric loading can be handled via the **Instantaneous Center of Rotation Method** or the **Elastic Method**.

For information on both methods see the *AISC 360-05 Manual*, Page 7-6 and the [Bolt Group Eccentricity](#) topic.

Weld Analysis Method

The design of welds with eccentric loading can be handled via the **Instantaneous Center of Rotation Method** or the **Elastic Method**.

For information on both methods see the *AISC 360-05 Manual*, Page 8-9 and the [Weld Calculations](#) topic.

Consider Bolt Hole Deformation

This check-box defines whether deformation at bolt holes at service load is a design consideration or not. If this is checked it means it *is* a design consideration. If not, it is *not* a design consideration. This impacts the Bolt Bearing Strength equations. See the [Bolt Bearing Strength](#) topic for more information.

When using the [Canadian code](#) (*CSA S16-2009*, *CSA S16-2014*, or *CSA S16-2019*), this box is automatically unchecked.

Check Weld Filler Metal Matching (CJP/PJP Weld Checks)

This check-box gives an option whether or not to check the weld material against the base material per the AWS. See the [CJP Weld Strength](#) section for more information.

Check Rotational Ductility

This check-box gives an option whether or not to check shear connections for the ability to rotate, thus verifying a "pinned" connection assumption.

Full Shear Ecc. Considered

This setting effects how the bolt group eccentricity is calculated for shear tab shear connections only. If it is selected then the program assumes that shear tab is always an Extended Configuration and uses the full distance from the bolt group to the face of the support as the eccentricity.

The image shows a software interface with a technical drawing on the left and a settings dialog box on the right. The drawing depicts a steel connection with dimensions: a vertical plate of 12.00 units, a horizontal plate of 3.50 units, and a bolt line with a spacing of 0.50 units. The bolt line is offset from the vertical plate by 1.50 units. The settings dialog box, titled '(Global) Project Settings', has a 'Solution' tab. It includes a 'Design Code' dropdown set to 'AISC 14th (360-10): LRFD'. Under 'Bolt Group Analysis Method', 'Center of Rotation' is selected. Under 'Weld Analysis Method', 'Elastic' is selected. A red box highlights the 'Full Shear Ecc. Considered' checkbox, which is checked. Other checked options include 'Consider Bolt Hole Deformation', 'Check Weld Filler Metal Matching', 'Check Rotational Ductility', and 'Check Weld Base Mat. Thick'. A 'Save As Defaults' button is at the bottom right of the dialog. Below the dialog is a table titled 'Rotational Ductility, Erection Stability' with a 'PASS' status. The table has two columns: 'Check Rotational Ductility' and 'Pass'. The 'Configuration' row is highlighted with a red box and shows 'Extended'. The table also includes technical specifications for plate thickness (t), maximum weld thickness (t_{max-weld}), maximum bolt thickness (t_{max-bolts}), and maximum plate thickness (t_{max-plate}).

Check Rotational Ductility	Pass
Configuration	Extended
t	0.38 in
t _{max-weld}	0.88 in
t _{max-bolts}	0.44 in
t _{max-plate}	0.64 in

Rotational Ductility, Erection Stability **PASS**

Per page 10-102 through 10-104 of Steel Design Manual
Plate thickness

Max. plate thickness to avoid weld failure (AISC 14th p. 9-14)

Max. plate thickness to avoid bolt failure (AISC 14th p. 10-104, exceptions)

Max. plate thickness to avoid plate rupture (AISC 14th p. 9-14)

If it is not selected, and the connection meets all the requirements of the Conventional Configuration (on *AISC 14th ed. Steel Design Manual page 10-102*), then the program will set the eccentricity as half the distance from the bolt group centroid to the face of support or as otherwise required per Table 10-9.

The screenshot shows the (Global) Project Settings dialog box with the 'Solution' tab selected. The 'Design Code' is set to 'AISC 14th (360-10): LRFD'. Under 'Bolt Group Analysis Method', 'Center of Rotation' is selected. Under 'Weld Analysis Method', 'Elastic' is selected. The 'Full Shear Ecc. Considered' checkbox is unchecked and highlighted with a red box. A red arrow points from this checkbox to the 'Configuration' row in the summary table below, which is also highlighted with a red box. The summary table shows 'Rotational Ductility, Erection Stability' with a 'PASS' result. The 'Check Rotational Ductility' is 'Pass' and the 'Configuration' is 'Conventional'. The table also lists parameters like t , $t_{max-weld}$, $t_{max-bolts}$, and $t_{max-plate}$ with their respective values and references to the AISC Steel Design Manual.

Rotational Ductility, Erection Stability		PASS
Check Rotational Ductility	Pass	
Configuration	Conventional	
t	0.38 in	Per page 10-102 through 10-104 of Steel Design Manual
$t_{max-weld}$	0.88 in	Plate thickness
$t_{max-bolts}$	0.44 in	Max. plate thickness to avoid weld failure (AISC 14 th p. 9-14)
$t_{max-plate}$	0.64 in	Max. plate thickness to avoid bolt failure (AISC 14 th p. 10-104, exceptions)
		Max. plate thickness to avoid plate rupture (AISC 14 th p. 9-14)

Notes:

- If the shear tab connection has any axial load, then it is assumed to be an Extended Configuration per *AISC 14th ed. Steel Design Manual page 10-103*.
- Both the AISC and CSA codes give parameters when bolt group eccentricity can be ignored for the [Bolt Shear Strength](#) check. If you wish to ignore the eccentricity when these codes allow for it make sure this check-box is unchecked. For more information see the [Bolt Checks](#) topic.

PZ Deform. Considered (or PZ Detail Considered for CSA S16)

This check-box determines which set of equations to use for the Column Panel Zone Shear limit state check on beam to Wide Flange column moment connections.

- **US Design (AISC 360-10 References below):**
 - When **PZ Deform. Considered** is not selected, the check will consider section J10.6(a).
 - When **PZ Deform. Considered** is selected, the check will consider section J10.6(b).
- **Canadian Design (CSA S16-14 References below):**
 - When **PZ Detail Considered** is not selected, the check will consider clause 27.2.4.2(b).
 - When **PZ Detail Considered** is selected, the check will consider clause 27.2.4.2(a).

Check Weld Base Mat. Thickness

This check-box determines if the program will include the base material proration factor, α to reduce the capacity of Weld Strength per the "Connecting Element Rupture Strength at Welds" section on page 9-5 of the AISC Steel Design Manual (14th edition). For more details on how this factor is calculated, see the [Weld Checks](#) topic. Because this requires some engineering judgment, this check-box allows the user to turn off this adjustment factor all together.

Include AISC 15th Out of Plane Web Checks

This check-box determines if the program will include the out of plane checks on a Wide Flange column web per the AISC 15th edition Steel Design Manual page 9-14 through 9-17. These checks were not included in older versions of the AISC Design Manuals so these can be applied retroactively along with the AISC 13th and 14th editions if you so choose. This is not available for the Canadian design codes. See the [Column Web Checks](#) section for more details on the following checks:

- [Column Web Punching Shear](#)
- [Column Web Axial Yielding](#)
- [Column Web Flexural Yielding](#)

Reduce Available Bolt Strength by Prying Effects Factor Q

This check-box determines if the program will use the [Alternative Method](#) of considering prying forces on bolts per the AISC 15th (360-16) and 14th (360-10) page 9-13 or AISC 13th (360-05) page 9-12. This is not available for the Canadian design codes.

Display r_0 and r_u Calculations for Welds

This check-box enables the display of detailed weld calculations, including the determination of r_0 and r_u values. Activating this feature provides greater transparency and insight into the weld calculations within the program.

Connection Modeling Process

RISACONNECTION is set up to consider multiple connections within a single project file. The idea is that an entire structure could have all of its connections in the same file. Each connection within the project is named something unique to let the designer know where this connection exists in the structure.

Note:

- This procedure is for standalone use only. For information on using RISACONNECTION integration see the [RISAFloor and RISA-3D Integration](#) topic.

Creating a Project

Creating a new project in RISACONNECTION is as easy as pressing  or going to **File-New-Project**:

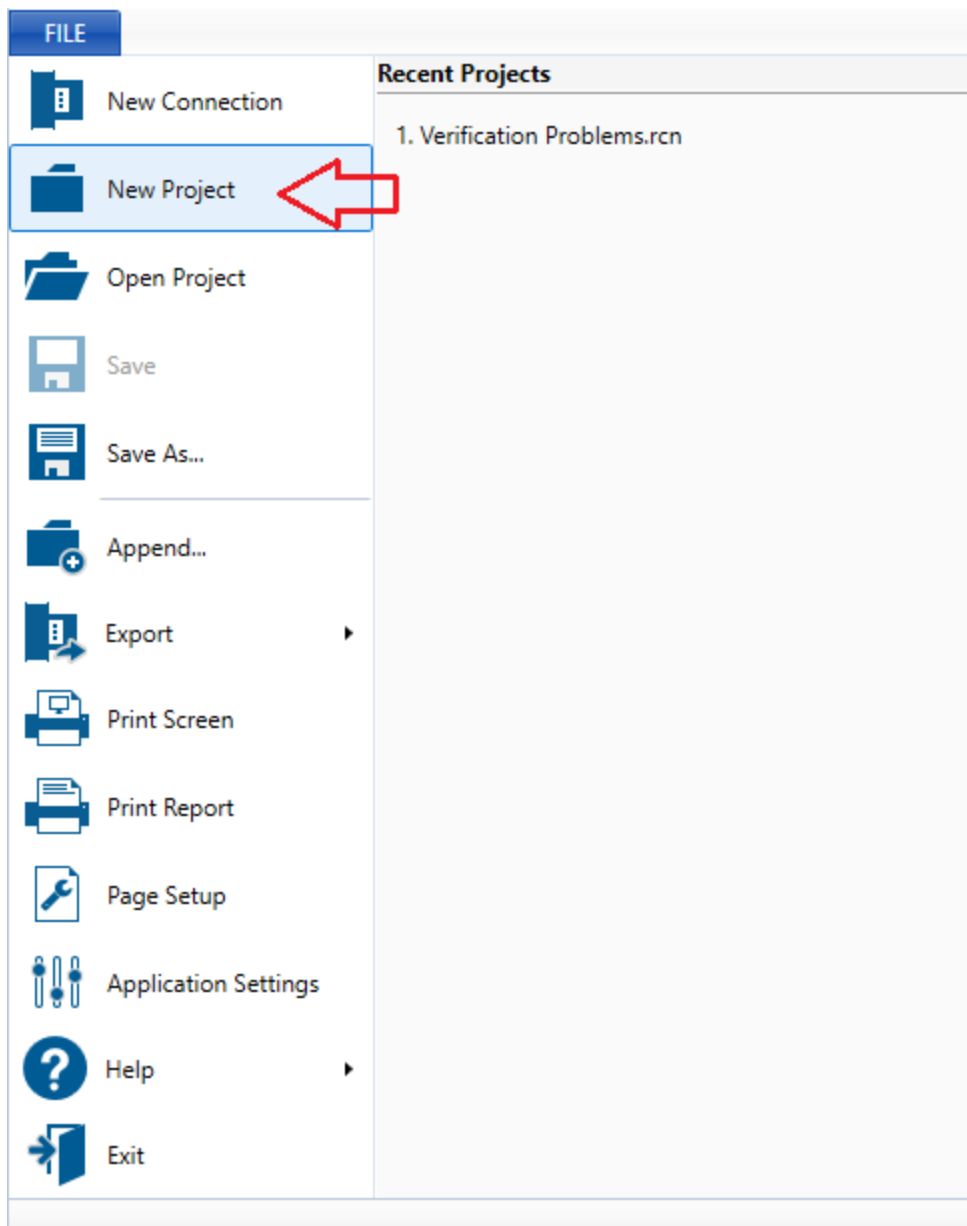

Once the project is added it shows up in the [Project Explorer](#).

Now you can modify the **Global Parameters** information into the [Global Parameters](#) dialog  to be appropriate for your project.

Creating a Connection

Once the project has been created, the next step is to add individual connections. To add a connection simply press the **Add New Connection** button  or right-click the project in the [Project Explorer](#) and choose **Add Connection**:

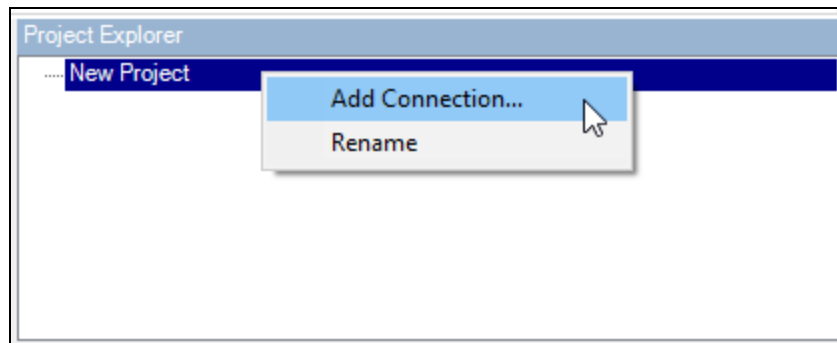

This opens up the **Create New Connection** dialog:

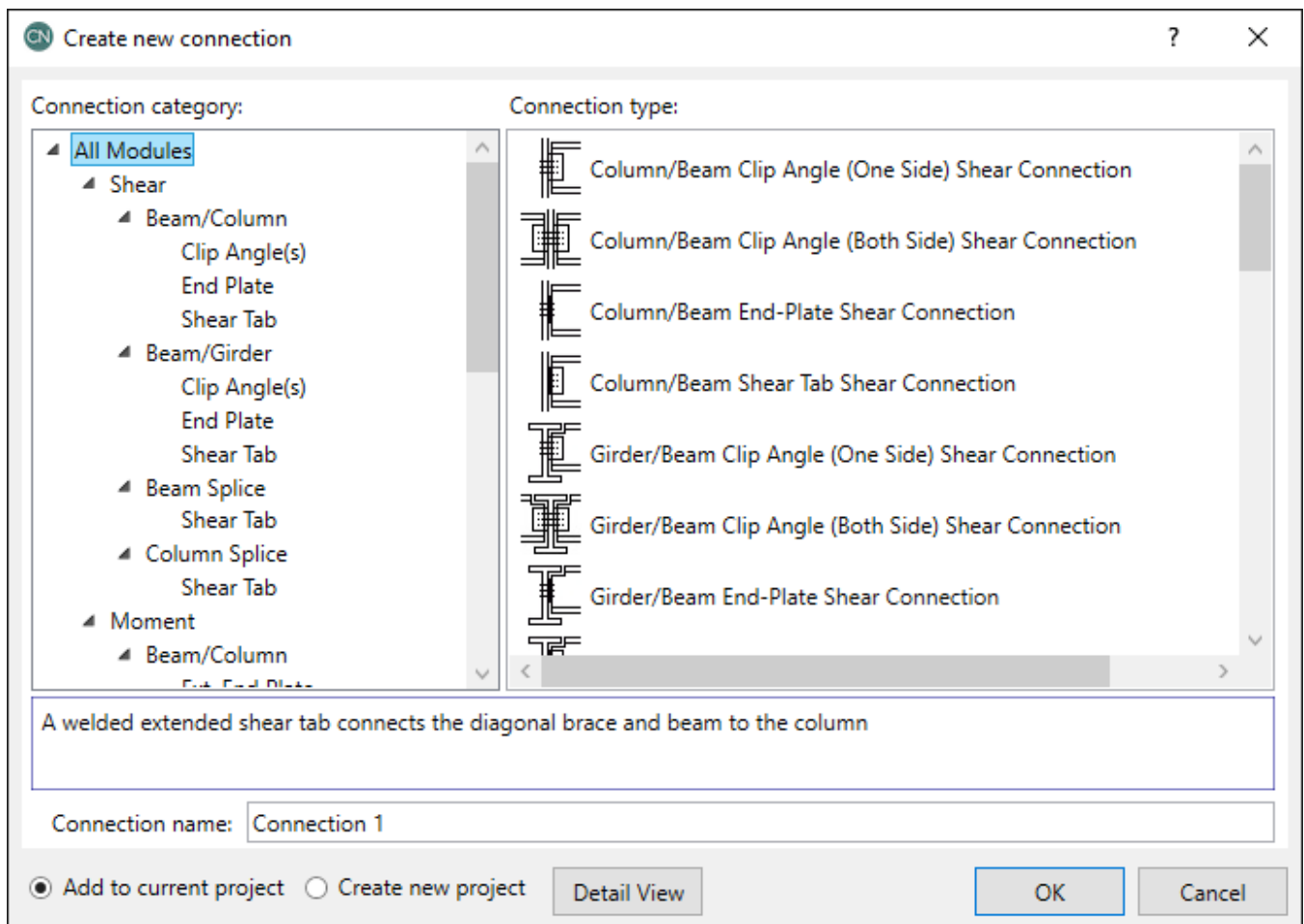

The **Connection Category** allows you to narrow down your selection options in the **Connection Type**. Here you can see all of the available connections in the program.

The **Connection Name** allows you to give the connection a unique name and either add this connection to the current project or create a new project with this connection in it. Press **OK** and the connection will be added.

You can also click the **Detail View** button (introduced in version 13) at the bottom of the new connection dialog. This will allow you to quickly specify more details about the connection before opening up the connection.

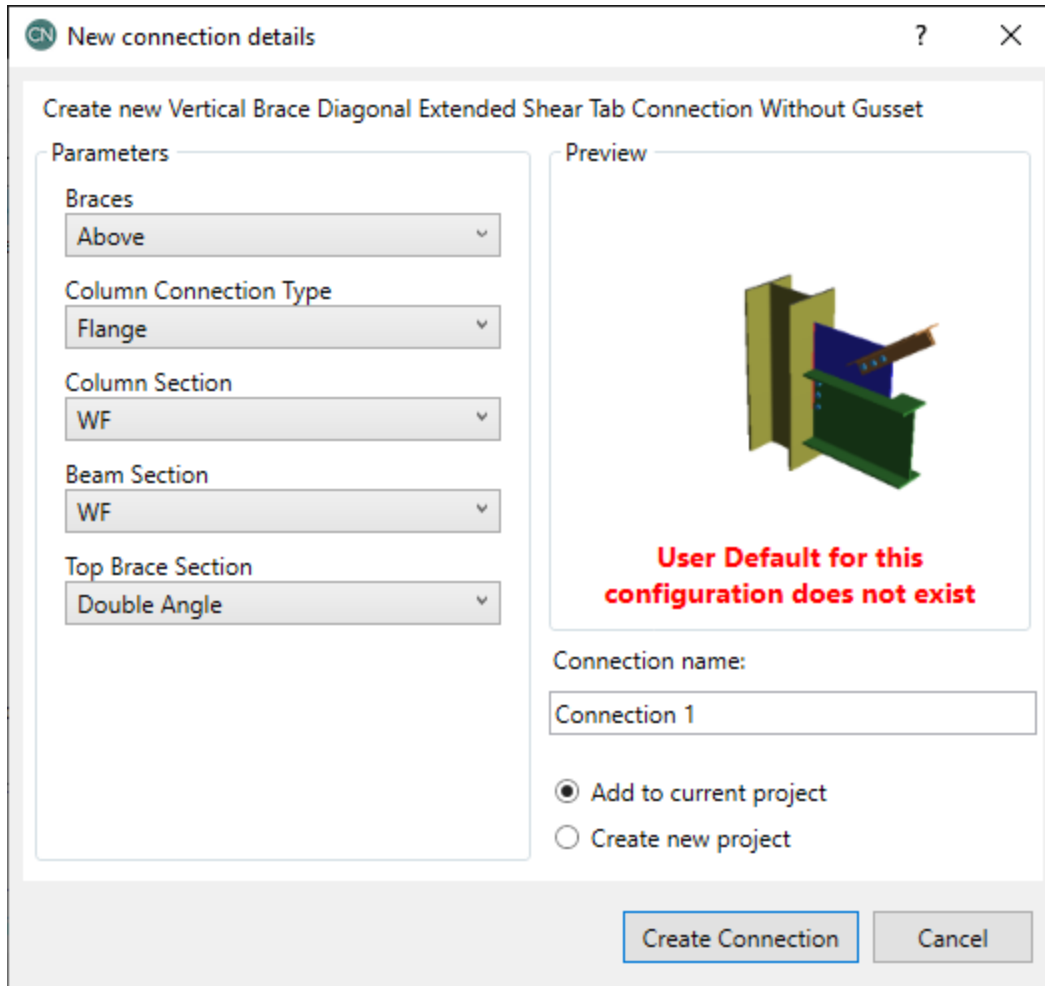

This dialog will also show a message if a user default for this configuration has not yet been set up. See the [Defaults Viewer](#) section for more information on connection defaults and how to set them.

Once added, connections will show up under the project in the **Project Explorer**. Here we can right-click the individual connections to cut, copy, paste, rename or delete the connection.

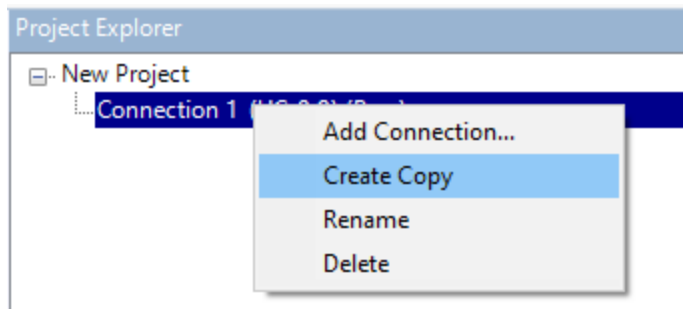

Thus, if you have several connections that are very similar you can create an initial connection and simply copy that connection and make minor revisions.

See [Seismic Detailing](#) for instructions on how to define a prequalified connection for seismic moment frames.

Available Connections

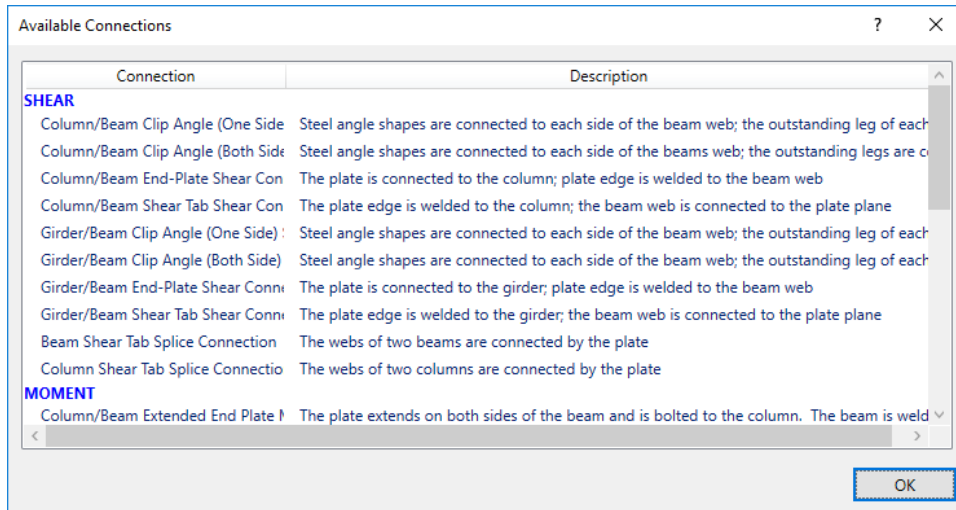

The **Available Connections** section provides a list of the connections currently supported in the program and is only a viewer. You may also review the [Available Connection Types](#) topic for details about the shape types allowed with each of these connections.

Defaults Viewer

The defaults viewer (added in RISACONNECTION version 13) allows you to view the program defaults for a specific connection.

It is important to note that it is possible to have various defaults for a single connection type. This is because each connection type can have a variety of different configurations (i.e. Column shape, beam shape, brace shape, etc). The program will store a default configuration for each permutation of the connection type and the default viewer allows you to quickly access these defaults.

A quick example of this is shown below where several configurations of a Vertical brace Chevron Connection is shown. Each of these configurations will have a different default stored in the program(6 different defaults - one for each configuration shown) and the default viewer allows you to view the defaults for each configuration.

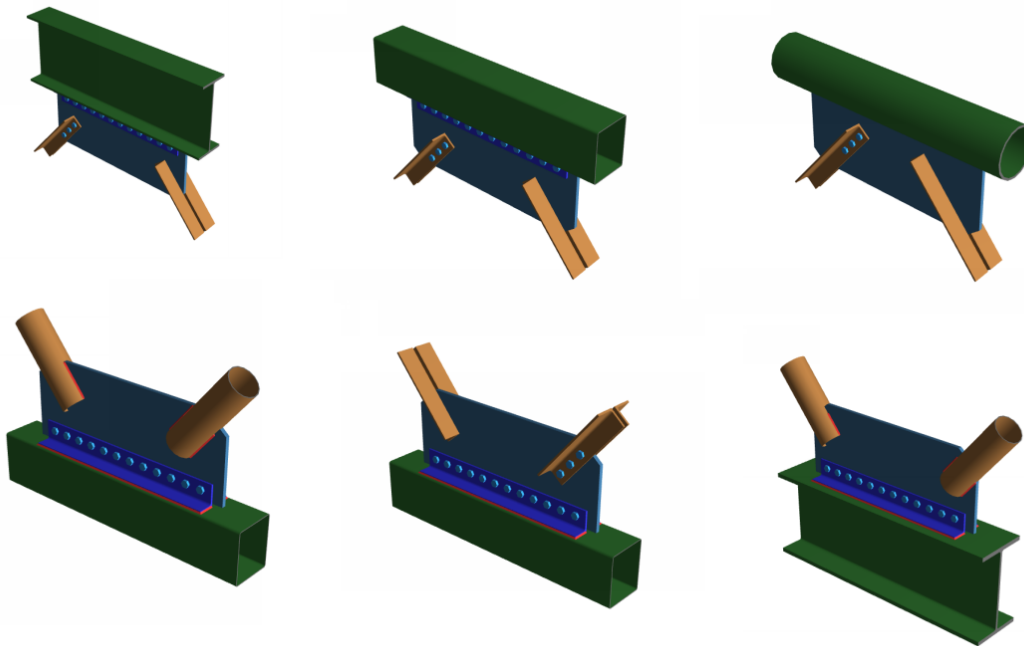

Accessing the Defaults Viewer

To access the default viewer, you can click on the **Defaults Viewer** button in the upper toolbar.

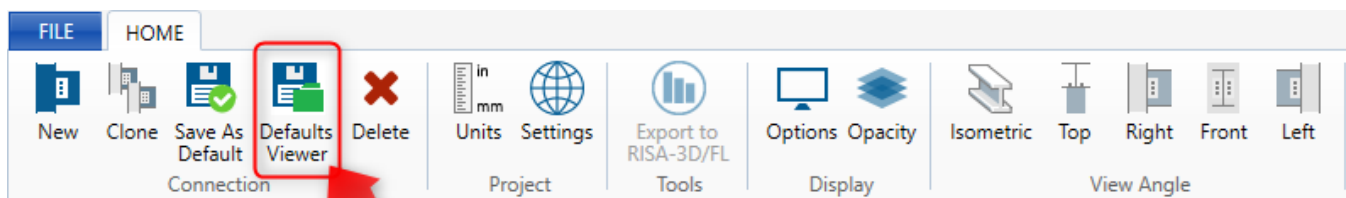

Defaults Viewer Interface

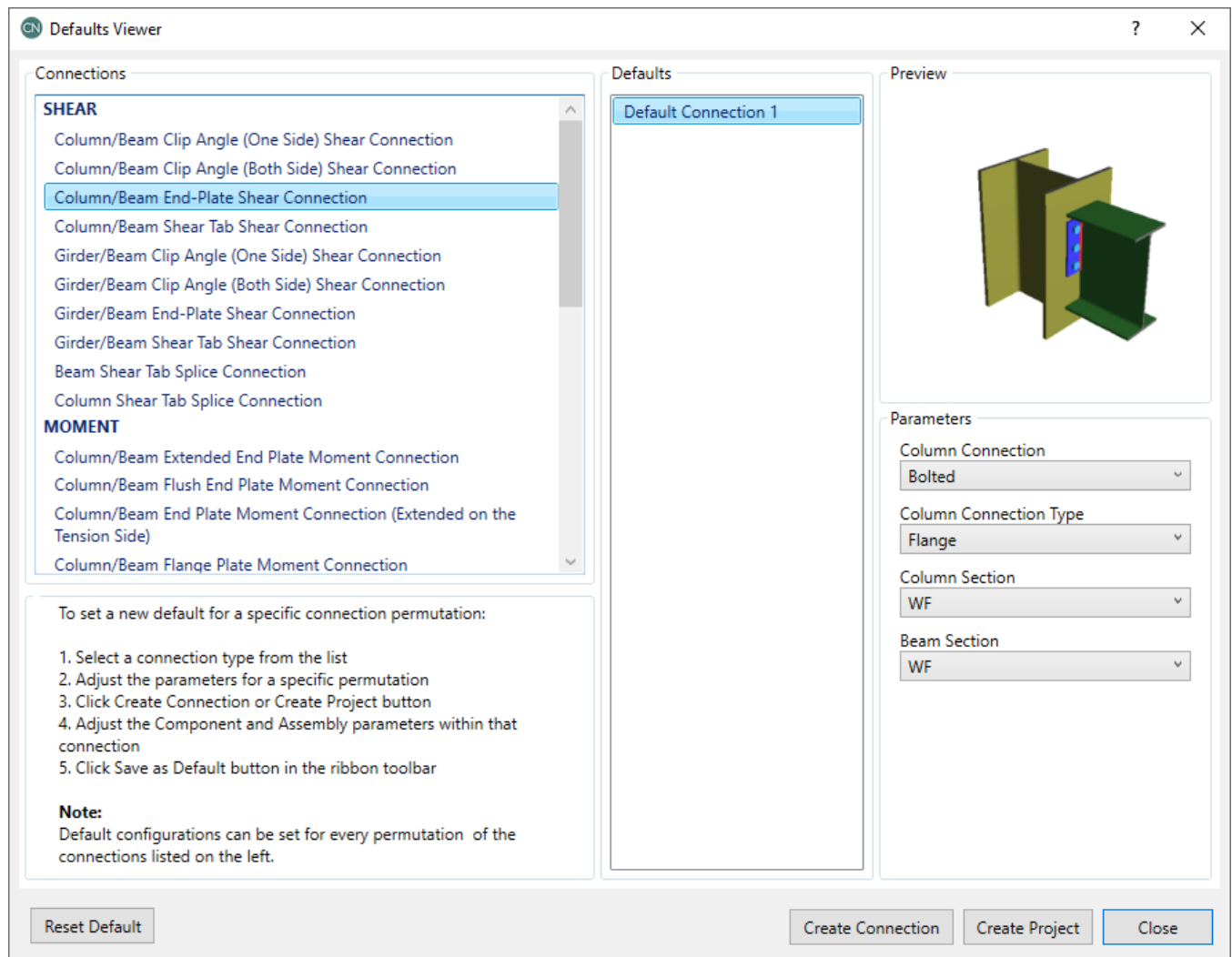

Once in the defaults viewer, you will want to select the specific connection that you are interested in on the left. The connections are categorized by type (Shear, Moment, etc).

After selecting a connection, you will see any user defined defaults show up in the Defaults list. Only user defined defaults will show in this list so there will not be any defaults that show in this list if you have not yet set any up. Please see the [Setting up a new default](#) section for more information on how to do this.

You can quickly change the parameters on the right side of the dialog in the Parameters section to change the connection configuration. If a user default is not defined for the specified configuration then the program will show the following message: *User Default for this configuration does not exist.*

Preview

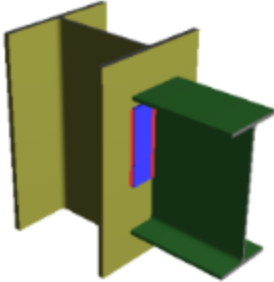

User Default for this configuration does not exist

Parameters

Column Connection
Welded

Column Connection Type
Flange

Column Section
WF

Beam Section
WF

Setting up a new Default

To set a new user defined default configuration you can follow the instructions:

1. Select the connection that you want to set from the list of connections
2. Adjust the parameters for the connection to match you desired configuration
3. Click Create Connection

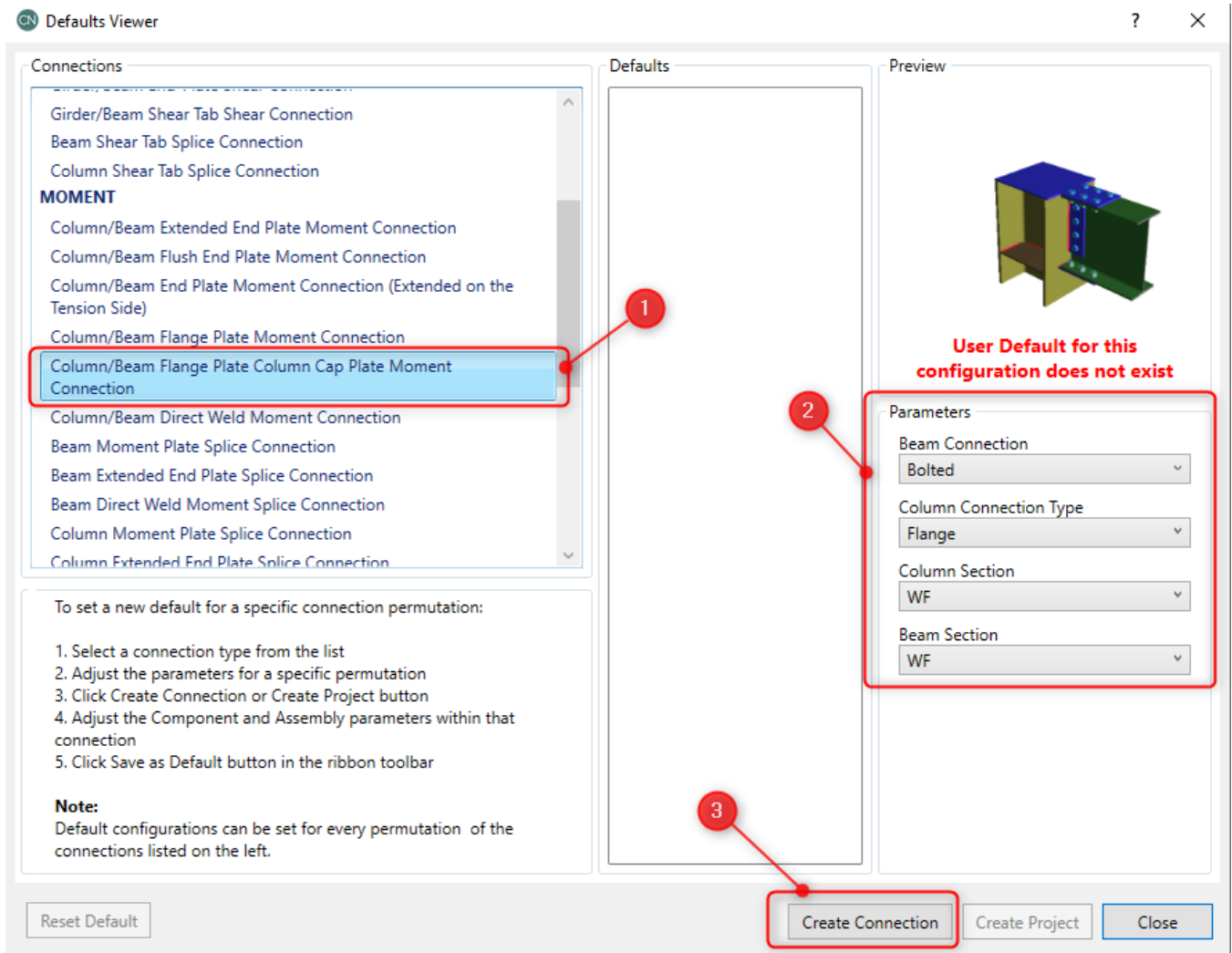

4. Adjust the connection and assembly settings (how many bolts, weld size, etc) within RISACONNECTION as you normally would.

5. Click the **Save As Default** button in the ribbon toolbar

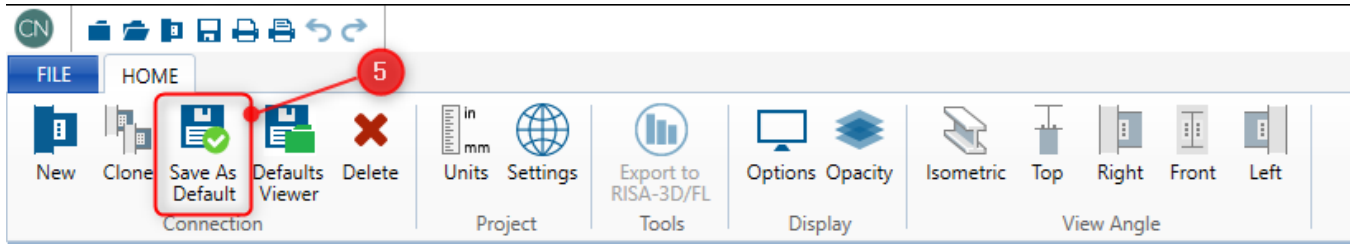

Note:

- This procedure is tailored for if you start in the Defaults Viewer dialog. You can always click the **Save As Defaults** button at any point in your connection modeling to save the default for that connection

Defaults Viewer Footer buttons

Reset Default: This option resets the selected user defined default to the original program default.

Create Connection: This option creates a new connection based on the connection type and selected parameters.

Create Project: This option will create a new project based on all the user defined defaults that were created for the selected project.

Close: This option will close the Defaults Viewer dialog.

Results

As soon as a new connection is created, or an old connection is modified, RISACONNECTION automatically updates the design calculations for both LRFD and ASD design if in standalone mode. These results may be viewed in the associated tabs from the Report Connection View. If you are working with the integration using RISAFloor or RISA-3D then the Project Explorer gives a summary of your results as well. See the [RISAFloor and RISA-3D Integration](#) topic for more information.

Connection View for Connection 21

LRFD Results | Members | Components

RISA Connection 21 LRFD

Beam Moment Plate Splice Connection
Connection design

Material Properties:

Left Beam	W410x60	G40.2-350W	$F_y = 350.00$ MPa	$F_u = 450.00$ MPa
Right Beam	W410x60	G40.2-350W	$F_y = 350.00$ MPa	$F_u = 450.00$ MPa
Plate	P5.99x309.88x154.76	G40.2-300W	$F_y = 300.00$ MPa	$F_u = 450.00$ MPa
Moment Plate	P10.01x170.10x459.99	G40.2-300W	$F_y = 300.00$ MPa	$F_u = 450.00$ MPa

Input Data:

Shear Load	0.00 kN	User Input Shear Load
Moment	0.00 kN-m	User Input Moment
Axial Load	0.00 kN	User Input Axial Force
Puf_c	0.00 kN	Required Flange Force (compression)
Puf_t	0.00 kN	Required Flange Force (tension)

Note: Unless specified, all code references are from AISC 360-10

Collapse All Expand All

Limit State	Required	Available	Unity Check	Result
Geometry Restrictions at Left Beam Web				PASS
Geometry Restrictions at Right Beam Web				PASS
Geometry Restrictions at Left Beam Flange				FAIL
Geometry Restrictions at Right Beam Flange				FAIL
Plate Shear Yield	0.00 kN	166.98 kN	0.00	PASS
Left Beam Shear Yield	0.00 kN	658.12 kN	0.00	PASS

These reports may be expanded (by clicking on each Limit State) to reveal the design calculation. This report not only calculates the code check for you, but also lists out the equation used, the various input variables, the load, the strength, and then the ultimate result: failure or passing.

Plate Shear Rupture at Beam	2.2295 kips	215.3250 kips	0.01	PASS
$R_n = 0.6 * F_u * A_{nv}$		$\phi = 0.75$ (I4-4)		
F_u	58.0000 ksi	Minimum tensile stress of material		
A_{nv}	8.2500 in ²	Net area subject to shear		
ϕR_n	215.3250 kips	Shear rupture strength		

Member Information

See the [Graphic Display](#) topic for more information.

Design Checks

For a detailed explanation of the specific design check see the table of contents to locate it in this manual.

Design Checks for Canadian Code

RISACONNECTION can perform code checks according to the Canadian (*CSA S16-2009*, *CSA S16-2014*, and *CSA S16-2019*) steel codes. This is offered only for the following connections:

- Shear Tab Connections
 - WF girders
 - WF or HSS Tube columns
- Clip Angle Connections
 - WF girders
 - WF or HSS Tube columns
- Direct Weld Moment Connections
 - WF or HSS Tube columns
- HSS Beam to Column Moment Connection
 - HSS Tube columns
 - HSS Tube beams
- Flange Plate Moment Connections
 - WF or HSS Tube columns
- Extended End Plate Moment Connections
- HSS to HSS Connections
- Vertical Diagonal Brace Connections
 - WF or HSS Tube columns
- Chevron Brace Connections
 - WF or HSS Tube beam
- Knee Brace Connections
 - WF or HSS Tube column
 - WF or HSS Tube beam

Connection Design Procedures

There is a difference in philosophy between the US and Canadian steel design codes. The AISC provisions seek to identify all possible failure modes. The CISC manual and CSA specification, on the other hand, try to limit the number of failure modes which need to be investigated by the engineer. They do this by ignoring failure modes which are not believed to control, or by combining multiple failure modes into a single simplified calculation.

The connection design procedures used in RISACONNECTION are based on the AISC design procedures, but modified to fit the CSA S16 code provisions. AISC formulas and phi factors have been replaced by CSA formulas and phi factors in most cases. Therefore, the program will generally try to check all possible failure modes, even when they are not likely to control. This means that some failure modes are calculated in circumstances when the CSA code says they do not need to be checked.

In some cases, there is not a direct CSA/CISC counterpart to an AISC equation. In those cases, some engineering judgment is required. RISA engineers have chosen to look for the CSA code provisions that are most similar to the AISC code provisions and use them. In some cases this may mean the code equations cited by RISACONNECTION come from a clause (like the seismic chapter) which CSA does not expressly require to be checked.

There are also instances where the CSA code requires a failure mode to be investigated but does not give any direct guidance on how to do so. In these cases, the equations used for the AISC checks will also be used for the Canadian code. The only differences would be the use of Canadian phi factors.

Accounting for the Weld Strength Reduction Factor, M_w

One significant difference between the AISC and CSA code provisions related to how the code accounts for fillet welds where the orientation of the weld segments vary. The Canadian code reduces the strength of some weld segments by the value M_w which can be as much as a 15% reduction. RISACONNECTION does not fully account for this

reduction at this time. Instead, the program identifies cases where some weld segment will have a M_w value of less than 1 and conservatively reduces all weld segments in those connections by 15%.

The result of these changes is that the RISACONNECTION results will not directly match the CISC capacity tables for welds.

Per CSA S16-19, Clause 13.13.2.2 updates the definition of M_w for weld groups with multiple orientations. RISACONNECTION continues to use the conservative approach of applying $M_w = 0.85$ to all weld segments rather than calculating individual values per segment.

Electrode Strength Coefficient, C_1

The [ICR method](#) of weld capacity calculations was done for E70xx welds. Extrapolating these values to higher strength welds introduces some uncertainty into the weld capacities. AISC uses an additional 10% strength reduction for weld strengths above 80 ksi and less than 200 ksi, as well as a 15% reduction for weld strength above 100 ksi. RISACONNECTION reduces Canadian weld strengths using the same approximate criteria.

Design Procedures for End Plate Moment Connections

The design procedure used for End Plate Moment connections comes primarily from AISC Design Guides #4 and #16.

Note:

- The Phi factor for bolt moment strength calculations has been changed to 0.8 to be more consistent with CSA provisions.
- The Phi factor used for End Plate Shear Yielding has been changed to 0.9 to be more consistent with CSA provisions.
- Section 21.3b of the 2014 CSA provisions is NOT considered for column flange bending. Instead the formulas from design guide 4 and 16 (based on column yield lines) are used same as they are for the AISC connections.

Rotational Ductility

The AISC manual has specific checks to ensure that shear connections are flexible enough to accommodate the end rotations of simple beams. These [rotational ductility](#) checks are given in the manual, based on the requirements of section J1.2. The CSA provisions have similar requirements in Clause 21.2, but the manual does not give specific guidance on how to address these requirements. For this reason, the procedure used for AISC connections will also be used when code checking to the CSA provisions. These requirement may be turned off by unchecking the box on the solution tab of the global parameters.

Lateral Stability / Stabilizer Plates

The CSA manual does not directly address the stability issues of extended shear tabs where the torsional flexibility of the plate can be insufficient to insure the lateral stability of the connection. In these cases, a stabilizer plate may be required per equation 10-6 of the AISC 14th edition.

Since this issue is not directly addressed by the CSA manual, this is checked using the AISC formulas directly. More information on RISACONNECTIONS implementation of these provisions is given in the [Stability and Geometry Checks](#) topic.

Elastic Method for Weld or Bolt Groups

The current version of the Canadian steel manual only gives the Instantaneous Center of Rotation (ICR) method for dealing with weld or bolt groups loaded eccentrically. However, the elastic method is still valid and conservative. Therefore, it is included as an option in the RISACONNECTION program. Furthermore, the elastic method is required for some weld groups where the ICR method is not fully defined. See the [Weld Checks](#) topic for more details.

The elastic procedures are based on the AISC steel manual procedures which are based off of the method described by Blodgett.

Coped Beams

Clause 14.8.1 requires that the effects of Copes be accounted for in the design of the member. For CSA S16-09 and CSA S16-14, the CISC Manual (page 3-59/3-63) references AISC provisions; therefore, [coped beam](#) failure calculations use the equivalent AISC 13th Edition equations for those code editions.

For CSA S16-19, the CISC Manual 12th Edition (page 3-63) now references Dowswell (2018) for flexural and shear web buckling in simple-coped beams. Since the Dowswell (2018) equations align with the AISC 15th Edition Steel Construction Manual guidance, RISACONNECTION uses AISC 15th Edition equations for Coped Beam Local Web Buckling under CSA S16-19.

The Coped Beam Flexural Rupture check is not required for CSA S16-19 as it is not referenced in the updated CISC 12th Edition guidance for this code edition.

For CSA S16-19, Section 13.11 now explicitly applies block shear provisions to welded connections via an added note. RISACONNECTION implements **Block Shear** and **Tearout** checks for coped beams with welded clip angles and other welded connections. Failure planes for welded connections follow AISC Commentary J4.3 methodology. When the efficiency factor (U_t) is not defined for a specific welded connection type per the CSA, then $U_t = 1.0$ is used conservatively.

Bolt Material Properties

When using an imperial designation for the bolt material (A325, A490), RISACONNECTION uses the strength of the bolt from the ASTM, not the "soft conversion" values given in the CISC manual for table 3-3.

ASTM F3125/F3125M high-strength bolts are used per the 2019 edition.

Bolt Hole Deformation

The code checks for bolt bearing in the Canadian code do NOT have the option for reducing the capacity of the connection in cases where limiting the deformation of the bolt hole is desired.

Bolt Tension for Eccentric Load - Special Case

RISACONNECTION does not use the procedure described in the CISC manual on page 3-36. That procedure is described as an easy to use and conservative procedure. Instead, RISA uses the procedure described in the [Eccentricities](#) topic. This procedure is more complicated, but should be more accurate and less conservative.

Bolt Hole Sizes

The assumed size for bolt holes is based on clause 22.3.5.2 of the CSA specification and Table 3-48 of the CISC manual. Slotted bolt holes are based on the Miscellaneous Fastener Detailing Data on page 6-166.

Note:

- For some diameters (1/2", 5/8"), the program will not allow for oversize or slotted bolt holes.
- Short Slot hole lengths are assumed to be 2mm larger than the oversize bolt hole diameter.
- Long Slot bolt holes are assumed to be 2.5 times the nominal bolt diameter.

Slip Critical Bolts

Slip Critical Bolts are not currently checked for the Canadian code.

Weld Access Holes

The assumed dimensions of Weld Access Holes for direct weld moment connections are based on figure 5.1 of CSA W59-2003. The program always assumes the beam is a rolled shape.

Material Properties for CSA S16-19

For CSA S16-19, material properties are based on G40.20/G40.21-13 (R2018) per the CISC Manual 12th Edition (Table 3-22 and Table 6-3). The following differences apply relative to earlier Canadian code editions:

- Grade 300W — Ultimate Tensile Strength (F_u): $F_u = 440$ MPa for WF shapes, Channels, Angles, and Plates. This differs from CSA S16-09 (450 MPa). For WT brace shapes assigned Grade 300W, $F_u = 440$ MPa is used, as the 450 MPa footnote in Table 3-22 applies only to the 300WT designation.
- Grade 380W — Shape Availability: Per CISC Manual 12th Edition, Table 6-3, Grade 380W is available in angles and bars only. If Grade 380W is selected for a Plate, Tube, or Pipe component when using CSA S16-19, the program will report No Calc for that element.
- Grades 380W–550W — Minimum Yield Stress (F_y) for Thick Plates: For plate thickness $t > 65$ mm, F_y values per CISC Manual 12th Edition Table 6-3 are now used.

Column Stiffener Checks for Moment Connections

Panel Zone Shear Capacity

Clause 27.2.4 of the CSA provisions give regarding the strength of a columns panel zone in a seismic moment connection. Checking this strength is not explicitly required for other types of loading. However, to be consistent with parallel AISC provisions, RISACONNECTION will always run the panel zone shear check, regardless of the applied load.

The higher Panel Zone capacity due to increased the detailing requirements of 27.2.4.3 are NOT assumed in the RISACONNECTION calculations. The capacity of the panel zone is NOT reduced based on the presence of axial load as it would be if the AISC provisions were selected.

Demand Shear for Web Doubler Plates

Clause 21.3 appears to assume that the capacity of the web will be based on clause 13.4.2 (shear strength for Plastic Analysis). RISACONNECTION uses the panel zone capacity from 27.2.4 (as described above) to determine the shear demand on the web doubler plate.

Buckling of Web Doubler Plates

The AISC design guide on column strengthening / stiffening recommends a maximum b/t ratio for the doubler plates to prevent local buckling of the doubler plate under applied shear stress. For the Canadian code, RISACONNECTION uses an h/t ratio of $1014/\sqrt{F_y}$ for this maximum ratio. This is based on the h/t limits given in clause 13.4.1.1. Note: this max ratio must be calculated using MPa for the units of the yield stress.

Column Web Yielding and Buckling

Clause 21.3 (a) and (b) give equations for the yielding or buckling of the column web. These provisions assume that web buckling can only occur for class 3 or class 4 webs. RISACONNECTION will always check the web for BOTH failure modes regardless of the web classification.

For Bolted end plate connections, the formula for web yielding is taken as $(12*t_{fc} + 2*t_p + t_{fb}) * F_y * t_{wc}$. This increase accounts for the larger spread of force allowed by the presence of the end plate.

For Bolted end plate connections, the formula for web buckling is taken as $640,000 * t_{wc} * (12*t_{fc} + 2*t_p + t_{fb}) / (h/t_{wc})^2$. This increase accounts for the larger spread of force allowed by the presence of the end plate.

RISAConnection uses the method described in the commentary to clause 21.3 to reduce the Web Yielding and Buckling capacities when the connection is located close to the end of the column. This involves using a bearing distant of $(N + 4t)$ instead of $(N+10t)$.

Column Flange Bending

Clause 21.3 (a) does not directly address the situation where the concentrated force occurs close the top of the column. For this case, RISAConnection uses the AISC method of reducing the capacity by 50% whenever the connection is within $10*t_{fc}$ of the end of the column.

Column Web Crippling

Clause 14.3.2(a)(ii) for web crippling applies specifically to the bearing resistance of a beam. This is analogous to concentrated loads applied to columns, but is not directly mentioned in the connection section of the CSA code. Since this is described as a web crippling capacity calculation, RISAConnection uses it wherever AISC connections are checked for web crippling.

Transverse Stiffener Checks

For the r value calculation, RISAConnection is conservatively ignoring the presence of the column web. Rather than including the $25t_w$ web strip discussed in clause 14.4.2.

Plate Interaction for Welded Connections

Per CSA S16-19, Clause 21.12 introduces a strength interaction equation for welded connection plates subjected to combined moment, normal force, and shear:

$$\frac{M_f}{M_p} + \left(\frac{N_f}{T_r}\right)^2 + \left(\frac{V_f}{V_r}\right)^4 \leq 0.8$$

This check replaces separate plate flexural yield and rupture checks for CSA S16-19. It applies to:

- Shear tab connections (all configurations for CSA S16-19; extended configuration only for CSA S16-09 and CSA S16-14)
- Brace connection gusset plates
- Other welded connection plates subject to combined loading

HSS Checks per the CIDECT Manual

HSS members are available for design per the CSA S16 design codes for the following connections: Shear Tab, Clip Angle (One Side), Direct Weld Moment, Flange Plate Moment, HSS to HSS, Vertical Diagonal Brace, Chevron Brace, and Knee Brace. The HSS section checks are all referenced per the *CIDECT Design Guide 3 (2nd Edition) for Rectangular Hollow Section (RHS)* members and the *CIDECT Design Guide 1 (2nd Edition) for Circular Hollow Section (CHS)* members. The majority of HSS checks come from *CIDECT Design Guide Tables 4.1 and 7.1*. The applicability of this table depends on the "Range of Validity" at the end of the table. This means that if a connection falls outside these limits then the procedures given by this table may not be sufficient to guarantee a safe connection. It does not necessarily mean that the given code checks are invalid. It may mean that the parameters of the connection fall outside the limits of existing test data or that other limit states not listed could control. These parameters are checked as part of the HSS Limitations limit state, which includes checks for:

- Wall Slenderness
- Yield

- Ductility
- Class
- Material
- Connection Width Ratios
- Aspect Ratios

These limit states are very similar to those used in the AISC Chapter K checks. See the [HSS Checks](#) section for more details about which limit states are checked.

Resistance Factor, ϕ

Per CIDECT Clause 1.2.1, the resistance should be multiplied by 0.9 when the nominal yield strength of the HSS member exceeds 355 MPa.

Additional HSS Weld Provisions (CSA S16-19)

Clause 13.13.4.3 includes updated provisions for fillet welds to HSS members:

Minimum Weld Strength:

When using the "effective length concept," fillet welds to HSS must be designed for the greater of:

- Applied force in the connected member, **OR**
- 50% of the yield resistance of the connected HSS wall

This applies only when loading is compression normal to axis of weld. The 50% yield resistance is calculated as:

- Double fillet: $V_c = 2 \times (0.58 \times F_{yc} \times t_c) \times L_w$
- Single fillet: $V_c = (0.58 \times F_{yc} \times t_c) \times L_w$

Directional Strength Enhancement Factor:

Per CISC Commentary 13.13.4.3, the factor **(1.00 + 0.50sin^{1.5} θ)** is **not applied** to fillet welds to HSS when using the effective length concept. The reduction factor **M_w** is still applied.

Effective Weld Size for Short Welds:

When deposited weld length is less than max(38 mm, 4 × weld size), the effective weld size is reduced to: $D_{w,eff} = 0.25 \times$ Effective weld length.

Canadian Code Limitations

The current implementation of the Canadian code does not support the following features:

- End Plate Shear Connections
- Beam or Column splice connections
- Slip Critical Bolts
- Non-matching electrodes are not supported for CSA S16-19. For fillet welds, PJP welds, and CJP welds under CSA S16-19, RISAConnection currently requires matching electrodes. The electrode matching check (using Table 4 from CSA S16-14) is applied.

Stability and Geometry Checks

This section focuses on checks concerned with stability, ductility and geometry restrictions.

Erection Stability

RISACONNECTION provides checks for erection stability, as prescribed in the AISC 14th Edition Manual. The following checks are performed:

Double Angle Shear Connection

A warning is given if angle length does not exceed 1/2 of the T dimension of the supported beam. See AISC 14th Edition Manual, Page 10-9.

End-Plate Shear Connection

A warning is given if plate length does not exceed 1/2 of the T dimension of the supported beam. See AISC 14th Edition Manual, Page 10-49.

Shear Tab (Single-Plate) Connection

A warning is given if plate length does not exceed 1/2 of the T dimension of the supported beam. See AISC 14th Edition Manual, Page 10-106.

Single Angle Shear Connection

A warning is given if angle length does not exceed 1/2 of the T dimension of the supported beam. See AISC 14th Edition Manual, Page 10-133.

Erection Stability		PASS
Check condition: $L_y \geq (d - 2 * k_{des}) / 2$		
L_y	12.0000 in	Connector length (vertical)
d	15.9000 in	Beam depth
k_{des}	0.8320 in	Beam fillet
L_{min}	7.1180 in	Min connector length

Rotational Ductility

RISACONNECTION provides checks for rotational ductility for shear connections, as prescribed in the AISC 14th Edition Manual. These checks are only done when enabled through the [Global Parameters](#) dialog. Rotational ductility ensures that a shear connection will allow the necessary rotation to act as a "pinned" connection without a brittle failure.

The following checks are performed:

Double Angle Shear Connection

A warning is given if angle thickness exceeds 5/8". See AISC 14th Edition Manual, Page 10-9.

End-Plate Shear Connection

A warning is given if plate thickness exceeds 5/8". See AISC 14th Edition Manual, Page 10-49

Shear Tab (Single-Plate) Connection

In order to ensure adequate rotational ductility in a shear tab shear connection the following three conditions must be satisfied:

- The plate must yield in flexure prior to any weld failure due to flexure
- The plate must yield in flexure prior to any bolt failure due to flexure
- The plate must yield in flexure prior to rupturing in flexure
- The internal tmax-weld ductility check for shear tabs is consistent with the AISC Manual recommendation that the support fillet weld be sized approximately as 5/8tp so that the plate yields before the weld.

Configuration Classification by AISC Edition

The criteria for classifying a shear tab as Conventional versus Extended configuration differ between AISC editions:

- AISC 14th and 15th Editions — A shear tab may qualify as a Conventional configuration when the bolt spacing satisfies the applicable conditions listed above and all other criteria on AISC 15th Edition Manual pages 10-87 through 10-90 are met.
- AISC 16th Edition (360-22) — A shear tab qualifies as a Conventional configuration only when the bolt spacing is exactly 3 inches. Any other bolt spacing forces the connection to be classified as an Extended configuration regardless of other parameters. See AISC 16th Edition Manual pages 10-48 through 10-51.

When the Extended configuration is assigned under AISC 360-22, the following note is included in the design report:

"The beam is assumed to be braced at points of support."

This assumption is inherent to the Extended configuration design procedure and is flagged in the report for the user's awareness.

The plate's flexural yield capacity is a direct function of its thickness. If a plate is too thick then its flexural yield capacity can be greater than the other capacities listed above, resulting in a non-ductile failure due to flexure.

Each of the three conditions above checks the maximum thickness based on AISC 360-10 (14th edition) eqn (10-3):

$$t_{max} = \frac{6 \cdot M_{max}}{F_y \cdot d^2}$$

The calculation of M_{max} is as follows:

- **T_{max-weld}** uses the Instantaneous Center of Rotation method to calculate $M_n = M_{max}$. This is equivalent to calculating M_n per AISC 14th edition equation (J2-7) which is very complex.
- **T_{max-bolts}** also uses the Instantaneous Center of Rotation method to calculate the bolt eccentricity coefficient, C' . The C' coefficient is defined in the AISC 14th Edition, Eqn 7-21:

$$C' := \sum_{i=1}^n \left(l_i \cdot \left(1 - e^{-\left(\frac{10 \cdot l_i \cdot \Delta_{max}}{t_{max}} \right)^{0.55}} \right) \right) \quad \text{AISC Steel Design Manual Equation (7-21)}$$

- Then the maximum moment is calculated based on the bolt shear capacity. This is then converted into a maximum allowed thickness per AISC 14th Edition, Eqn 10-3.

$$M_{max} := \left(\frac{F_v}{0.9} \right) \cdot A_b \cdot C'$$

Bolt shear strength derived from AISC Steel Design Manual eqn.(10-4)

$$t_{max_bolts} := \left(\frac{6 \cdot M_{max}}{F_y \cdot d^2} \right)$$

Maximum plate thickness per AISC Steel Design Manual eqn. (10-3)

- **T_{max-plate}** uses AISC 14th edition eqn (9-4) to calculate $M_n = M_{max}$. Note, M_{max} is taken as the unfactored capacity for the t_{max} check.

For reference see AISC 14th Edition Manual, Pages 9-14 and 10-104.

Rotational Ductility, Erection Stability		PASS
Check Rotational Ductility	Pass	
t	0.3750 in	Plate thickness
t _{max-weld}	0.8801 in	Maximum allowed plate thickness to avoid weld failure
t _{max-bolts}	0.4375 in	Maximum allowed plate thickness to avoid bolt failure
t _{max-plate}	0.6419 in	Maximum allowed plate thickness to avoid plate rupture
Check Erection Stability	Pass	Condition: $L_y \geq (d - 2 \cdot k_{des})/2$
L _y	12.0000 in	Connector length (vertical)
d	15.9000 in	Beam depth
k _{des}	0.8320 in	Beam fillet
L _{min}	7.1180 in	Min connector length

Minimum Weld Size for Ductility

In addition to the t_{max} checks above, RISACONNECTION includes a supplementary check for minimum weld size based on plate thickness per the AISC Steel Manual recommendations (13th ed. p.10-101, 14th ed. p.10-102, 15th ed. p.10-87).

Check: Weld Size $\geq (5/8) \times t_p$

Applicability:

- Only when Check Rotational Ductility is enabled in Global Project Settings
- Only for 36 ksi and 50 ksi plate materials
- Only for double fillet welds (not CJP welds)

Affected Connections:

- Column/Beam Shear Tab Shear Connection
- Girder/Beam Shear Tab Shear Connection
- Vertical Brace Diagonal Extended Shear Tab Connection (certain configurations)

This check can be toggled on/off using the "Check 5/8* t_p (Ductility)" drop down box in the Components section of the Connection Properties. The check is enabled by default.

Connection Properties		
>	Connection	
>	Connection Category	
>	Loading (LRFD)	
∨	Components	
∨	Column Section	W14X90
	Material	A992
>	Beam Section	W16X36
>	Plate Section	P0.38x3.50x12.00
∨	Column Weld	E70
	Type	Double Fillet
	Fillet Size, Sixteenths.	4.000
	Check $5/8 \times t_p$ (Ductility)	Yes
>	Beam Bolts	3/4" Group A-N
>	Assembly	

Note:

- This check is more conservative than the $t_{max-weld}$ check and does not account for weld electrode strength. In cases where this check fails but $t_{max-weld}$ passes, users may choose to disable the $(5/8) \times t_p$ check using the drop down box shown above.

Single Angle Shear Connection

No rotational ductility checks are done for single angle connections. The AISC manual gives no guidelines on criteria, and these connections are typically considered to be sufficiently ductile regardless of configuration.

Bolts Located Between Horizontal Welds

In the Shear Tab Connection module, when bolts are located between two horizontal welds, the connection lacks sufficient rotational ductility to be considered a proper shear connection. Therefore, the program will automatically fail such configurations under geometry restrictions due to inadequate rotational ductility as shown below.

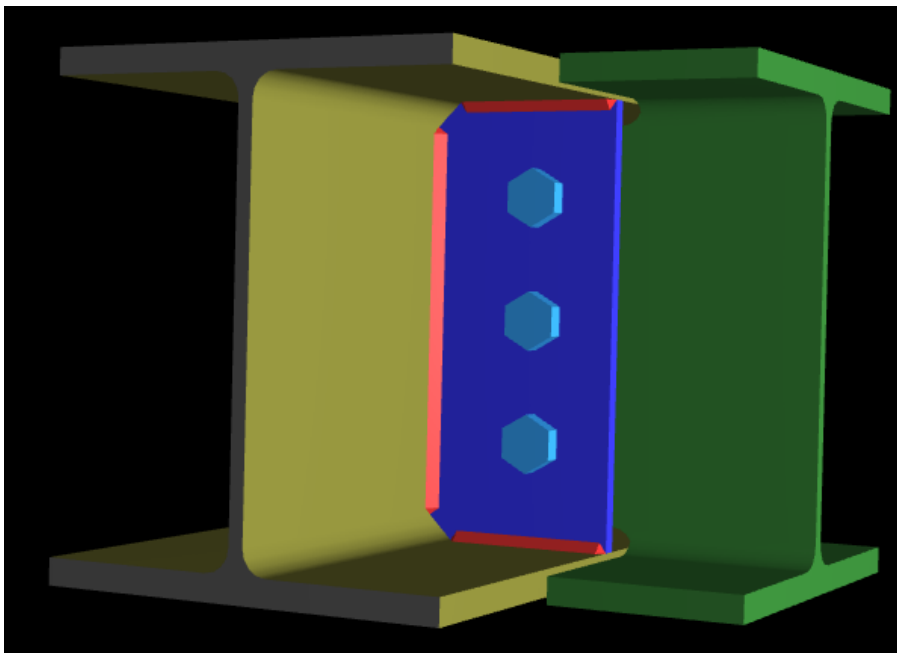

Limit State	Required	Available	Unity Check	Result
Geometry Restrictions at Beam				FAIL
Check Min Bolt Spacing	Pass	Condition: $S_{min} \geq (2+2/3) * d_{bolt}$	(J3.3)	
S_{min}	3.00 in	Min bolt spacing		
d_{bolt}	0.75 in	Bolt diameter		
Check Max Bolt Spacing	Pass	Condition: $S_{max} \leq \min(12.00 \text{ in}, 24*t)$	(J3.5a)	
S_{max}	3.00 in	Max bolt spacing		
t	0.36 in	Thickness of governing element (Beam)		
Check Min Edge Distance	Pass	Condition: $ED_{min} \geq ED_{allow}$	(J3.4)	
Check Max Edge Distance	Pass	Condition: $ED_{max} \leq \min(6.00 \text{ in}, 12*t)$	(J3.5)	
Check Bolt Placement	Fail	Bolts are located between horizontal welds		

Bolt Geometry Restrictions

In these checks the program will check bolt spacing and edge distances against code prescribed minimums and maximums. These are checked for each element that is bolted in the program. Thus, this check will be given for each bolted element in a connection. When we do these checks we do them for both the member and the connector. We will check the worst case between the member and the connector.

Geometry Restrictions at Column				PASS
Check Min Bolt Spacing	Pass	Condition: $S_{min} \geq (2+2/3) * d_{bolt}$	(J3.3)	
S_{min}	3.0000 in	Min bolt spacing		
d_{bolt}	1.0000 in	Bolt diameter		
Check Min Edge Distance	Pass	Condition: $ED_{min} \geq ED_{allow}$	(J3.4)	
Check Max Edge Distance	Pass	Condition: $ED_{max} \leq \min(6.0000 \text{ in}, 12*t)$	(J3.5)	
Check Bolt Constructability	Pass	Condition: $h - p_f - p - p_c > d_h$		
h	15.0400 in	Clear distance between beam flanges		
p	4.0000 in	Column bolts pitch		
p_f	2.0700 in	Column bolts flange pitch		
p_c	1.5000 in	Compression bolts flange pitch		
d_h	1.0625 in	Bolt hole diameter		

Check Minimum Bolt Spacing

Section J3.3 of the AISC 360-10 specification gives a minimum spacing of $2 \frac{2}{3} * d$. Thus, we will check both vertical and horizontal spacing of bolts against this minimum.

Check Maximum Bolt Spacing

Section J3.5 of the AISC 360-10 specification gives a maximum spacing requirement for bolts. The program considers the members in the connection NOT subject to corrosion, thus uses a maximum distance of $24 * \text{thickness of thinner plate}$ or 12 inches. J3.5(b) is not considered within the program. The program will check for the maximum edge distance in two orthogonal directions: the direction along the axial load in the connection, and the direction perpendicular to that.

Check Minimum Edge Distance

Section J3.4 of the AISC 360-10 specification gives minimum edge distance requirements. This provision considers both Table J3.4 and J3.5, depending on the type of hole. Thus, the program combines the values from both Table J3.4

and J3.5 for checking minimum edge distance.

Regarding sheared edges versus rolled edges, the program makes this assumption:

- All plate elements (shear tabs, end plates, flange plates, etc.) assume minimum edge distances based on sheared edges.
- All wide flanges and angles (and any other rolled shapes) assume minimum edge distances based on rolled or thermally cut edges.

Note that this check will only give detailed information if the minimum edge distance requirement was not met.

Check Maximum Edge Distance

Section J3.5 of the AISC 360-10 specification gives a maximum edge distance of 12*thickness of connected part not to exceed 6 inches. Note that this check will only give detailed information if the maximum edge distance requirement was not met.

Check Bolt Constructability

This check is applicable to all End Plate Moment connections. This common sense check ensures that the interior bolts do not overlap by limiting their spacing by a distance equal to the bolt hole dimension.

Limitation

The program does not do any checks for Entering and Tightening Clearances per Tables 7-15 and 7-16 of the AISC 14th Edition Manual. Thus, you will have to verify these dimensions manually.

Stabilizer Plates

The AISC 14th edition steel manual introduced a new stability check for extended shear tab connections to determine if the shear tab needs to be stabilized or not.

Lateral Stability / Stabilizer Plates		103.0776 kips	88.7224 kips	1.16	FAIL
$R_n = 1.500 * \pi * ((L * t_p^3) / a^2)$				$\phi = 0.90$	(14-th edition, eq. (10-6))
Connection requires stabilizer plates.					
V	100.0000 kips		Applied shear force		
P	25.0000 kips		Applied axial force		
$R = (V^2 + P^2)^{0.5}$	103.0776 kips		Resultant shear force		
a	5.5000 in		distance from the support to the first line of bolts		
t_p	0.3750 in		thickness of plate		
L	12.0000 in		depth of plate		
ϕR_n	88.7224 kips		available strength to resist lateral displacement		

If this check fails there are different ways to resolve it:

- When the shear tab connects to the web of a column, the user can add in stabilizer plates.
- When the shear tab connects to the web of a girder, the user can extend the shear tab up or down to connect to one or both of the girder flanges.
- When the shear tab connects to the flange of a column, the program cannot add stabilizer plates for this configuration. But, the user may be able to increase the depth or thickness of the shear tab to make the connection pass.

Material Checks

These material checks are common to many different connection types.

Shear Yield Strength

Shear yielding occurs over the gross cross section of elements in shear, such as shear tabs. The shear yielding capacity is calculated per the AISC 360-10 specification, section J4.2.

Clip Angle Shear Yield	80.0000 kips	194.4000 kips	0.41	PASS
$R_n = 2 * 0.6 * F_y * A_{gv}$		$\phi = 1.00$ (J4-3)		
F_y	36.0000 ksi	Minimum yield stress of material		
A_{gv}	4.5000 in ²	Gross area subject to shear		
ϕR_n	194.4000 kips	Shear yield strength		

A special case occurs when considering the beam web shear yielding. In this case the shear yielding capacity is calculated per the AISC 360-10 specification, section G2.1. The capacity is calculated per equation G2-1 and the C_v values are calculated using G2-2, G2-3, G2-4 and G2-5.

Beam Shear Yield	80.0000 kips	140.7150 kips	0.57	PASS
$R_n = 0.6 * F_y * A_{gv} * C_v$		$\phi = 1.00$ (G2-1)		
F_y	50.0000 ksi	Minimum yield stress of material		
A_{gv}	4.6905 in ²	Gross area subject to shear		
C_v	1.0000	Web shear coefficient (G2-2)		
ϕR_n	140.7150 kips	Shear yield strength		

Shear Rupture Strength

Shear rupture occurs over the net cross section of elements in shear, such as shear tabs. The shear rupture capacity is calculated per the AISC 360-10 specification, section J4.2.

Beam Shear Rupture	80.0000 kips	137.1971 kips	0.58	PASS
$R_n = 0.6 * F_u * A_{nv}$		$\phi = 0.75$ (J4-4)		
F_u	65.0000 ksi	Minimum tensile stress of material		
A_{nv}	4.6905 in ²	Net area subject to shear		
ϕR_n	137.1971 kips	Shear rupture strength		

Plate Tension Yield

Tensile yielding occurs over the gross cross section of elements in tension such as flange plates in a moment connection or even the beam itself. The tensile yielding capacity is calculated per the AISC Specification J4.1.

Flange Plate Tension Yield	44.2396 kips	85.0500 kips	0.52	PASS
$R_n = F_y * A_g$		$\phi = 0.90$ (J4-1)		
F_y	36.0000 ksi	Minimum yield stress of material		
A_g	2.6250 in ²	Gross area subject to tension		
ϕR_n	85.0500 kips	Tensile yield strength		
d_m	16.2750 in	Moment arm between the flange forces		
R_{req}	44.2396 kips	Required Flange Force (tension)		

Tension Rupture

Tensile yielding occurs over the gross cross section of elements in tension such as flange plates in a moment connection or even the beam itself. This effective area is taken as the minimum of the [net area](#), or 85% of the gross area. The tensile rupture capacity is calculated per the AISC Specification J4.1.

Brace Tensile Rupture	100.0000 kips	191.9120 kips	0.52	PASS
$R_n = F_u * A_e$		$\phi = 0.75$ (D2-2)		
F_u	58.0000 ksi	Brace tensile stress		
A_e	4.4118 in ²	Effective net area $A_e = A_n * U$		
A_n	5.1650 in ²	Net area subject of tension		
$U_{D3.1}$	0.8542	Shear lag factor (table D3.1)		
U_{Bound}	0.4967	Shear lag factor (lower bound)		
U	0.8542	Governing shear lag factor, $\max(U_{D3.1}, U_{Bound})$		
ϕR_n	191.9120 kips	Brace tensile rupture strength		

Shear Lag Factor

For the braces in vertical brace connections a shear lag factor is included per the AISC 360-10 specification, Section D3.

Shear Lag Factor Lower Bound

The program also checks the shear lag lower bound factor per the Commentary to section D3 on page 16.1-284. This section allows the "ratio of the area of the connected element to the gross area" as a reasonable lower bound value.

$$U_{low\ bound} = \frac{A_i}{A_g}$$

<u>Brace Cross Section</u>	<u>Area, A_i</u>	<u>Area, A_g</u>

Shear Lag Factor for Pipe and Tube Braces

When AISC 360-22 (16th Edition) is selected, the eccentricity of connection \bar{x} used in the shear lag factor calculation per Table D3.1 is calculated explicitly for Pipe and Tube braces using the formulas below. For earlier AISC editions, \bar{x} is not reported separately in the check output.

Pipe Brace:

$$\bar{x} = R \sin \theta - tp/2$$

where:

- R = outer radius of the pipe
- $\theta = 90^\circ - \arcsin(tp/2R)$ (in radians)
- tp = gusset plate / knife plate thickness

The shear lag factor is then: $UD3.1 = 1 - \bar{x}/l$, per Table D3.1, Case 3.2-10.

Tube (Rectangular HSS) Brace:

$$\bar{x} = (b-2b^2)t+(H-2t)^2 / 2(2H+4b-4t)$$

where:

- t = tube wall thickness
- H = the dimension of the tube wall parallel to the gusset plate
- $b = B - t_p/2$, with B = the dimension of the tube wall perpendicular to the gusset plate
- t_p = gusset plate / knife plate thickness

The shear lag factor is then: $UD3.1 = 1 - \bar{x}/l$, per Table D3.1.

The lower bound shear lag factor U_{bound} is taken per AISC 360-22 Commentary to Section D3, page 16.1-348. The parameters \bar{x} , l , and $UD3.1$ are all reported in the Brace Tensile Rupture check output when AISC 360-22 is selected.

Gross and Net Areas

The gross area is the full cross-sectional area (ignoring the bolt holes). The net area removes the area of bolt holes from the gross area. This is done per AISC 360-10 section B4.3b which says that "the width of a bolt hole shall be taken as 1/16 in greater than the nominal dimension of the hole."

Beam Flexural Rupture

For Flange Plate Moment Connections, the nominal flexural strength of the beam is checked per AISC 360 equation F13-1.

Beam Flexural Rupture		720.0000 kips-in	2471.2738 kips-in	0.29	PASS
$M_n = F_u * A_{fn} * S_x / A_{fg}$				$\phi = 0.9$	(F13-1)
F_u	65.0000 ksi				Minimum tensile stress of material
A_{fn}	2.2532 in ²				Net area of tension flange
A_{fg}	3.0057 in ²				Gross area of tension flange
S_x	56.3522 in ³				Beam section modulus
ϕM_n	2471.2738 kips-in				Beam flexural rupture strength

Beam Tension Rupture

To compliment the Beam Flexural Rupture check (see above) for Flange Plate Moment Connections, the Beam Tension Rupture limit state will also be checked per AISC 360 equation D2-2 when there is an axial tensile force present. This check does not apply for zero axial or compressive loads.

Beam Tension Rupture		100.0000 kips	393.0469 kips	0.25	PASS
$R_n = F_u * A_e$				$\phi = 0.75$	(D2-2)
F_u	65.0000 ksi				Minimum tensile stress of material
A_e	8.0625 in ²				Effective net area $A_e = A_n * U$
A_n	8.0625 in ²				Net area of tension member
U	1.0000				Shear lag factor, Table D3.1, case 1
ϕR_n	393.0469 kips				Beam tension rupture strength

Block Shear Strength

Block shear is a combination of tensile rupture, and either shear yielding or shear rupture. The program checks both types of block shear per the AISC 360-10 specification, section J4.3.

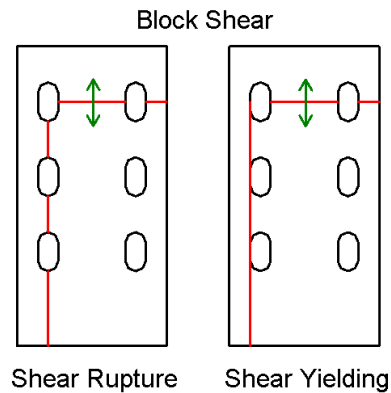

Note:

- When multiple rows of bolts are present for a block shear calculation, a U_{bs} value of 0.5 is used. Otherwise this value is taken as 1.0.
- Net area is calculated per AISC 360-10 section B4.3b which says that "the width of a bolt hole shall be taken as 1/16 in greater than the nominal dimension of the hole."

Block Shear on Un-Coped Beams

Block shear is not likely to control for beam webs unless the beam is coped. However, RISACONNECTION does check this failure state for completeness. The area of the beam flange directly above the web on either side will yield or rupture with the web. In the image below, for example, the orange area of the web represents shear yielding or rupture of the web area. The red shading is the area of the flange (one on each side of the web) that must also fail for the block shear limit state to occur.

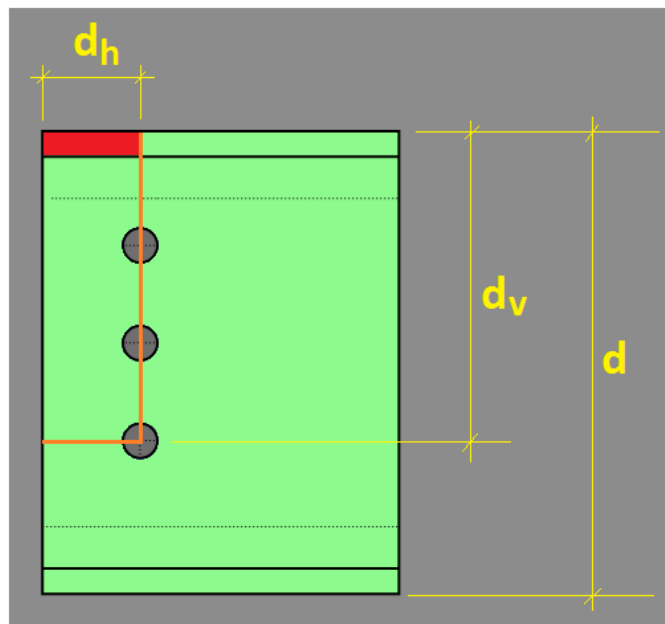
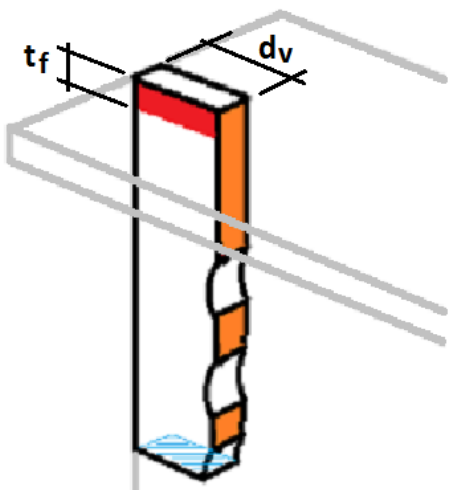
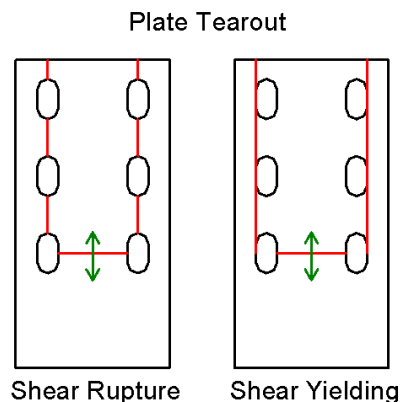

Plate Tearout

This failure mode is calculated as [block shear](#) using an "inside" perimeter rather than an "outside" perimeter.



Tearout Failure Patterns — U-Shaped and L-Shaped (AISC 360-22)

RISACONNECTION checks two tearout failure patterns depending on the connection type and applied loading:

- U-Shaped Tearout (Plate Tearout) — This is the standard tearout failure mode applicable to all AISC editions. The failure path forms a U-shape around the bolt or bolt group, with shear planes on two sides and a tension plane at the top or bottom. This check is performed for both pure shear loading and combined shear-and-axial loading configurations.
- L-Shaped Tearout — When AISC 360-22 (16th Edition) is selected, the beam fastener type is bolted, and an axial tension load is present, and a combined axial tension and shear load is present, an additional L-shaped tearout check is performed. In this failure mode, the failure path involves a single shear plane and a single tension plane, forming an L-shape at the corner of the bolt group. This failure mode is checked separately from the U-shaped tearout and may govern when the axial tension component is significant relative to the shear.

Comparison of U-shaped and L-shaped tearout failure path is shown below:

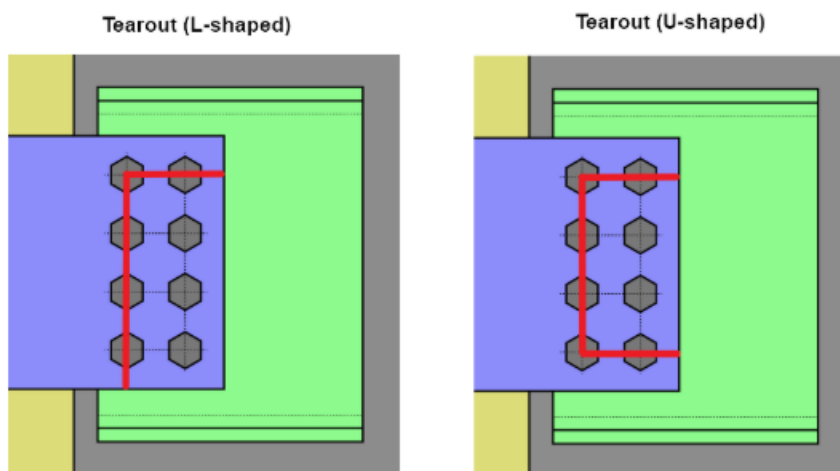

Both checks are reported individually in the design output when they are applicable. The net area subject to tension, A_n , is calculated differently for each pattern based on the geometry of the respective failure path.

Note: The L-shaped tearout check applies to all simple shear connections subject to combined axial tension and shear loading, including clip angle, shear tab, splice, and brace connections, when the beam fastener type is bolted. It is not performed when AISC 15th Edition or earlier is selected.

The **Net Area Subject to Tension (A_n)** and **Gross Area Subject to Shear (A_{gv})** used to calculate plate tearout is shown in the figure below.

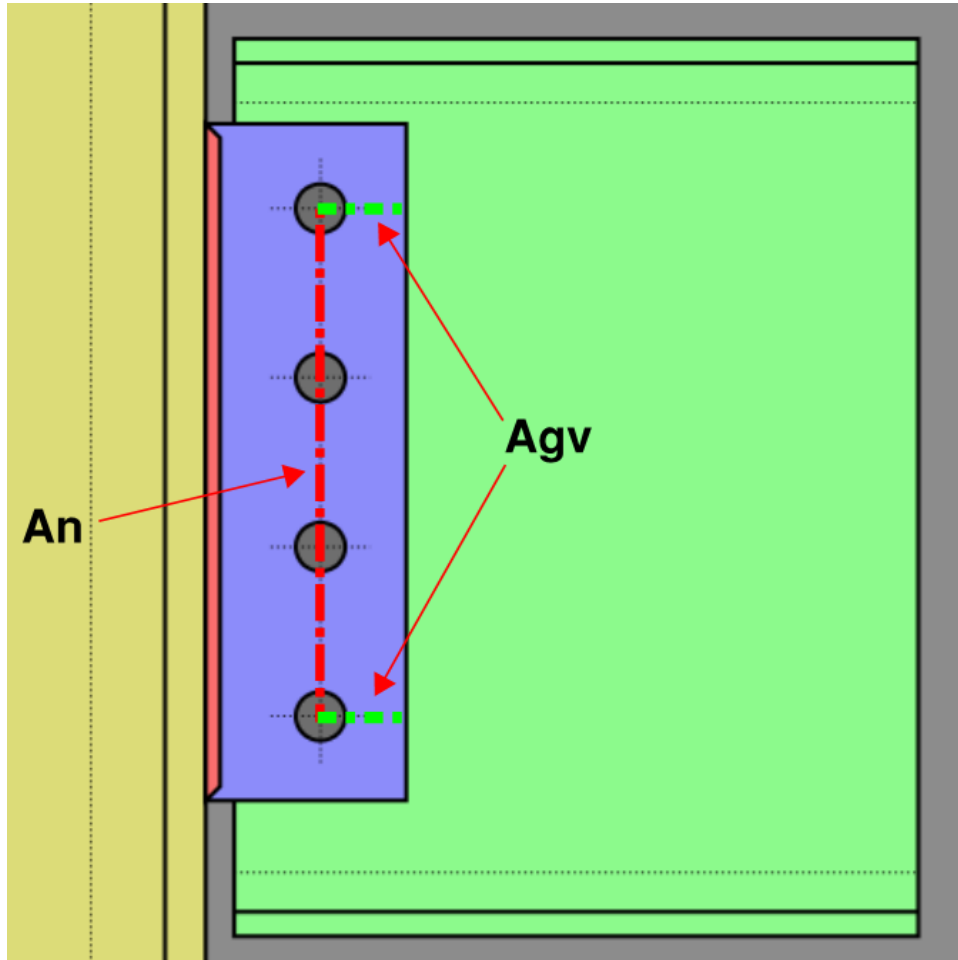

Gusset Plates

On gusset plates where the free edge of the tearout portion is not perpendicular to the direction of force an effective shear area is used. This program ignores the minimum amount of shear area necessary in order to produce a symmetric tearout pattern. See the dialog below.

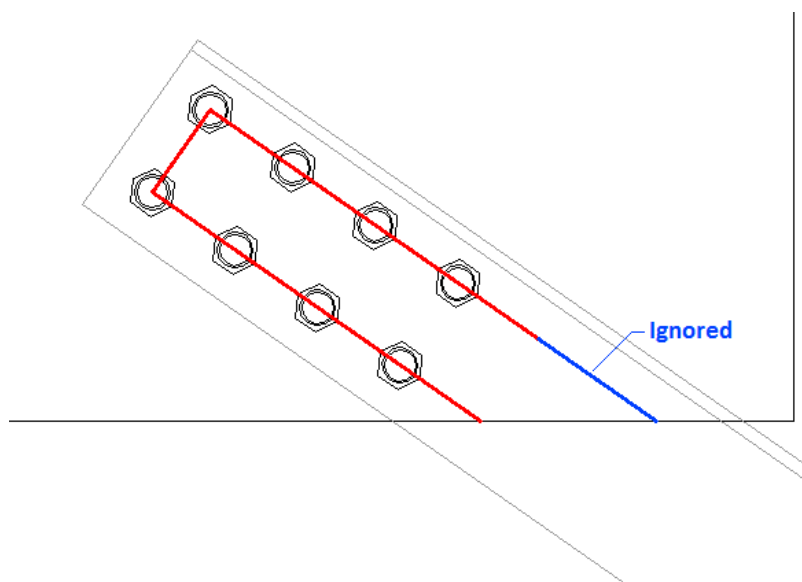

Beam Block Shear		60.0000 kips	123.9551 kips	0.48	PASS
$R_n = [\min(0.6 \cdot F_u \cdot A_{nv}, 0.6 \cdot F_y \cdot A_{gv}) + U_{bs} \cdot F_u \cdot A_{nt}]$			$\phi = 0.75$ (J4-5)		
A_{gv}	4.8300 in ²		<i>Gross area subject to shear</i>		
A_{nv}	3.9266 in ²		<i>Net area subject to shear</i>		
U_{bs}	1.0000		<i>Uniform tension stress factor</i>		
A_{nt}	0.3134 in ²		<i>Net area subject to tension</i>		
F_u	65.0000 ksi		<i>Minimum tensile stress of material</i>		
F_y	50.0000 ksi		<i>Minimum yield stress of material</i>		
ϕR_n	123.9551 kips		<i>Block shear strength</i>		

Plate Flexural Yielding

Flexural yielding occurs in elements of shear connections which take moment due to eccentricity. This effect is negligible, and is therefore ignored for clip angles and end plates. This effect also does not affect moment connections, since eccentricity may be ignored. The program does check flexural yielding for shear tabs, as it can be a controlling failure mode for extended configurations.

This check is not required if all of the following conditions are met:

- The shear tab is bolted to the beam.
- Only one row of bolts is present.
- There are between 2 and 9 bolts present.
- The bolts are less than 3.5" (horizontally) from the face of support.
- No oversized or long slotted holes are used.
- A horizontal edge distance equal to twice the bolt diameter is present on both the beam and the shear tab.
- The thickness of either the beam web or the plate is thin enough to produce ductile behavior.
- A minimum vertical edge distance is met for both the plate and beam (if coped).
- No axial force is present in the beam.

For more information, see the AISC 13th Edition Manual, page 10-101.

The design check for flexural yielding is outlined in the AISC 13th Edition Manual, page 10-103.

Note:

- The modified bolt ICR coefficient from the design procedure is omitted. Ductility checks are performed to ensure that this is acceptable.

Plate Flexural Yielding for Splice Connections

Per the specifications in the AISC design code, shear splices are designed for the following:

- Symmetrical shear splices will have both sides designed for full shear and axial load, and one half of the eccentric moment.
- Non-symmetrical shear splices will design the more rigid side for full shear, axial, and the full eccentric moment. The less rigid side will be designed just for the full shear and axial load.
- Rigidity is determined in the following way:
 - If one side is welded and the other bolted, the welded side is always assumed to be more rigid.
 - If both sides are bolted, the side with more bolts is assumed to be more rigid.
 - If both sides are welded, the side with the larger fillet weld size is assumed to be more rigid.

Please see page 10-139 of the AISC 14th edition (pg 10-129 of the AISC 13th edition) for more information.

Plate Flexural Rupture

Flexural rupture is a check exclusive to extended shear tab connections. For more information see [Flexural Yielding](#), and the AISC 14th Edition Manual, page 9-6.

Plate Flexural Rupture	12.00 kips	59.30 kips	0.20	PASS
$R_n = F_u * Z_{net} / a$		$\phi = 0.75$		
F_u	58.00 ksi	<i>Plate tensile strength</i>		
Z_{net}	12.00 in ³	<i>Plastic modulus of net section</i>		
a	8.80 in	<i>Design eccentricity</i>		
ϕR_n	59.30 kips	<i>Plate flexural rupture</i>		

Plate Flexural Rupture for Splice Connections

Per the specifications in the AISC design code, shear splices are designed for the following:

- Symmetrical shear splices will have both sides designed for full shear and axial load, and one half of the eccentric moment.
- Non-symmetrical shear splices will design the more rigid side for full shear, axial, and the full eccentric moment. The less rigid side will be designed just for the full shear and axial load.
- Rigidity is determined in the following way:
 - If one side is welded and the other bolted, the welded side is always assumed to be more rigid.
 - If both sides are bolted, the side with more bolts is assumed to be more rigid.
 - If both sides are welded, the side with the larger fillet weld size is assumed to be more rigid.

Please see page 10-139 of the AISC 14th edition (pg 10-129 of the AISC 13th edition) for more information.

Plate Compression Buckling

Compression yielding occurs over the gross cross section of elements in compression such as the shear plate or clip angle under compressive axial loads. The compression buckling capacity is calculated per the AISC Specification J4.4.

Compression Buckling of the Plate	50.0000 kips	145.8000 kips	0.34	PASS
$R_n = F_y * A_g$		$\phi = 0.9$	(J4-6)	
K	1.0000	Effective length factor		
L	2.0000 in	Unbraced length		
r	0.1084 in	Radius of gyration		
KL/r	18.4544	Plate slenderness		
F_y	36.0000 ksi	Capacity = Minimum Yield stress for $KL/r \leq 25$		
A_g	4.5000 in ²	Gross area subject to compression		
ϕR_n	145.8000 kips	Compressive strength		

$$K = 1.0$$

L = distance between the applied load and the resisting element

$$r = \sqrt{\frac{I}{A}} = 0.289 * t$$

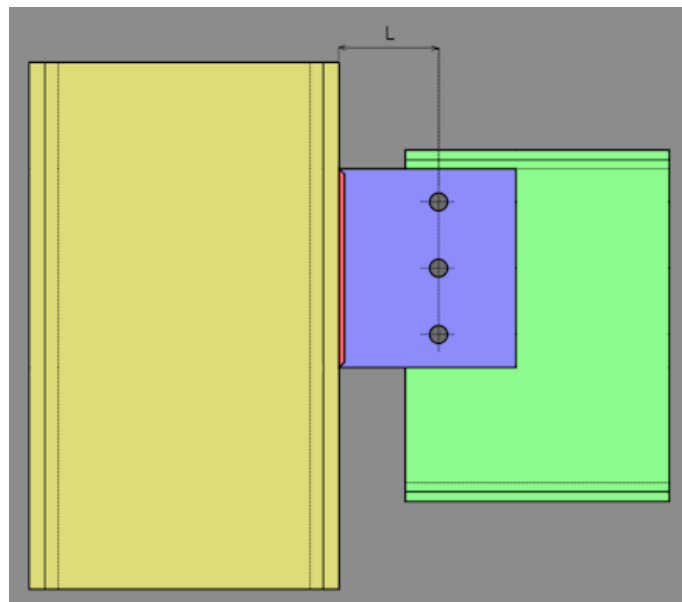

Shear Tab Interaction Checks

For cases where axial, shear and moment act simultaneously on a shear plate type of element, the program will consider interaction equations for yielding, rupture and buckling according to the discussions below.

Plate Flexural Yielding

If you have applied an axial force in addition to the shear load, the Plate Flexural Yielding check will change slightly to take into account the combined effects of the axial, shear and moment interaction. When this is the case, the capacities will be determined from the appropriate code sections (please see below) and the Unity Check value is determined from the following interaction equation:

Plate Flexural Yield		0.37	PASS
$(V_r/V_c)^2 + (P_r/P_c + M_r/M_c)^2 \leq 1$		<i>(AISC 14th Eq.10-5)</i>	
P_r	-10.00 kips	<i>user input tensile load</i>	
V_r	60.00 kips	<i>user input shear load</i>	
F_y	36.00 ksi	<i>plate yield stress</i>	
A_g	12.00 in ²	<i>gross area of the plate</i>	
Z_{pl}	36.00 in ³	<i>plastic modulus of the shear plate</i>	
V_c	172.80 kips	<i>available shear strength $V_c=1/\Omega*0.6*F_y*A_g$, $\Omega=1.50$, (J4-3)</i>	
e_x	6.00 in	<i>horizontal eccentricity</i>	
e_y	0.45 in	<i>vertical eccentricity</i>	
M_r	355.50 kips-in	<i>moment due to eccentricity = $V_r*e_x + P_r*e_y$</i>	
M_c	776.05 kips-in	<i>available moment $M_c=1/\Omega*(F_y*Z)$, $\Omega=1.67$</i>	
UC	0.37	<i>unity check per interaction equation, $(V_r/V_c)^2 + (P_r/P_c + M_r/M_c)^2 \leq 1$</i>	

This interaction equation is a variation of Equation 10-5 of AISC 14th edition. With the axial force being added directly with the moment which is more conservative than squaring each individual term.

For Column/Girder/Beam shear tab connections, a new Plate Interaction check is used for AISC 16th, combining axial, shear, and moment per AISC 360-22 Eq. 12-2 and 12-3; this replaces the previous two separate plate flexural interaction checks used for 14th/15th editions.

Note:

- For a shear tab, the demand moment is merely equal to the applied shear times the eccentricity of the connection.
- For a gusset plate, the moment (if present) is determined from the connection geometry using the [Uniform Force Method](#) calculations.
- Since this is a yielding equation, the moment capacity is assumed to be equal to the plastic capacity of the plate element.

The tension demand and capacity details are reported in the **Plate Axial Yield** calculations. The shear demand and capacity details are reported in the **Plate Shear Yield** calculations.

13th Edition Formula

The AISC 13th edition specifies a different interaction formula for yielding (refer to page 10-103) based on the Von Mises yield criteria.

Compression Loads

If you have a compressive axial load applied along with a shear load, the Plate Flexural Yielding interaction check works the same as it does for tension.

Plate Flexural Rupture

The Interaction equation for Plate Flexural Rupture is similar to what is shown for plate flexural yielding above. However, the rupture calculations ignore axial compression forces (which do not cause rupture). This was added to the program to address the case where axial tension forces may become significant. Specifically for cases where the plate is a gusset plate connected to a vertical brace in tension.

Plate Flexural Rupture		0.44	PASS
$(V_r/V_c)^2 + (P_r/P_c + M_r/M_c)^2 \leq 1$		<i>(Eq.10-5)</i>	
P_r	-10.00 kips	<i>user input tensile load</i>	
V_r	60.00 kips	<i>user input shear load</i>	
F_u	58.00 ksi	<i>Plate tensile stress</i>	
A_n	8.50 in ²	<i>Net area of the plate</i>	
Z_{net}	25.50 in ³	<i>Plastic modulus of net section</i>	
V_c	147.90 kips	<i>available shear strength $V_c = 1/\Omega * 0.6 * F_u * A_n$, $\Omega = 2.00$, (J4-4)</i>	
e_x	6.00 in	<i>horizontal eccentricity</i>	
e_y	0.45 in	<i>vertical eccentricity</i>	
M_r	355.50 kips-in	<i>moment due to eccentricity = $V_r * e_x + P_r * e_y$</i>	
M_c	739.50 kips-in	<i>available moment $M_c = 1/\Omega * (F_u * Z_{net})$, $\Omega = 2.00$</i>	
UC	0.44	<i>unity check per interaction equation, $(V_r/V_c)^2 + (P_r/P_c + M_r/M_c)^2 \leq 1$</i>	

For Column/Girder/Beam shear tab connections, a new Plate Interaction check is used for AISC 16th, combining axial, shear, and moment per AISC 360-22 Eq. 12-2 and 12-3; this replaces the previous two separate plate flexural interaction checks used for 14th/15th editions.

13th Edition Formula

The AISC 13th edition does not specify a formula to use for this situation. Therefore, engineering judgment is required. To ensure consistency between codes, RISACONNECTION uses the 14th edition equation even if the 13th edition code has been specified.

Plate Flexural Buckling

AISC does not have a true interaction equation for shear tabs subjected to shear in combination with axial compression. However, the commentary associated with AISC 14th edition equation 10-5 suggests that it should be done. Rather than using the square terms similar to equation 10-5, RISACONNECTION has taken a more conservative stance and directly added the two effects.

Plate Flexural Buckling		1.05	FAIL
$P / (P_n * \phi) + V / (V_n * \phi) \geq 1.0$		$\phi = 0.90$	(AISC 13 th Edition)
P	10.0000 kips	User input compression load	
V	60.0000 kips	User input shear load	
L	2.0000 in	Length of connecting element (distance between the applied load and resisting element)	
r	0.0722 in	Radius of gyration of the plate	
KL/r	27.6817	Slenderness ratio	
F _e	373.5197 ksi	Elastic critical buckling stress, per eqn E3-4, $F_e = (\pi^2 * E) / (KL/r)^2$	
F _y	36.0000 ksi	Plate yield stress	
F _{cr_Comp}	34.5767 ksi	Compression stress, per eqn E3-2, $F_{cr} = (0.658)^{F_y / F_e} * F_y$	
A _g	3.0000 in ²	Gross area of the plate	
P _n	103.7300 kips	Compressive capacity, per eqn E4-1, $P_n = F_{cr_Comp} * A_g$	
λ	0.4693	Buckling factor (pg 9.9)	
Q	1.0000	Buckling factor (pg 9.9)	
F _{cr_Flex}	36.0000 ksi	Critical stress, per pg 9-8, $F_{cr} = F_y * Q$	
S _{net}	4.3501 in ³	Section modulus of net section	
a	2.0000 in	Design eccentricity	
V _n	70.4711 kips	Plate flexural buckling, per pg 9-7, $V_n = (F_{cr_Flex} * S_{net}) / a$	
UC	1.0531	Unity check per interaction equation, $P / (P_n * \phi) + V / (V_n * \phi) \geq 1$	

Clip Angle Interaction Check

When AISC 360-22 (16th Edition) is selected, the separate Clip Angle Flexural Yield and Clip Angle Flexural Rupture checks used in earlier editions are replaced by a Clip Angle Interaction check. This check applies to clip angle shear connections where combined moment, shear, and axial force act simultaneously on the angle leg.

The interaction equation follows the same form as the Plate Interaction check per AISC 360-22 Eq. 9-1:

$$M_r / M_c + (P_r / P_c)^2 + (V_r / V_c)^4 \leq 1.0$$

where the component strengths P_c and V_c are drawn from the corresponding Clip Angle Axial Yield, Clip Angle Tension Rupture, Clip Angle Shear Yield, and Clip Angle Shear Rupture sub-checks, which are reported separately. As with the Plate Interaction check, the interaction check header does not display standalone Available and Required values — refer to the supporting sub-checks for individual component capacities.

This check is not performed when AISC 15th Edition or earlier is selected.

Angle Leg Bending

When the angle connection is welded and there is axial tension present in clip angle shear connection, the program automatically places a weld on the bottom of the clip angles as well to provide a weld configuration that can resist the load. However, allowing this type of force introduces the possibility that the connection will fail via angle leg bending and the limit state is introduced as shown below:

Angle Leg Bending	10.37 kips-in	13.67 kips-in	0.76
$M_n = t^2 * L * F_y / 4$			$\phi = 0.90$
M_{req}	10.37 kips-in	<i>Demand moment, $M_{req} = 0.5 * P * d_m$</i>	
P	5.00 kips	<i>Applied tension force</i>	
d_m	4.15 in	<i>Moment arm, $d_m = b + 0.5 * t_b$</i>	
b	4.00 in	<i>Angle width</i>	
t_b	0.29 in	<i>Beam web thickness</i>	
t	0.38 in	<i>Angle thickness</i>	
L	12.00 in	<i>Angle length</i>	
F_y	36.00 ksi	<i>Minimum yield stress of material</i>	
ϕM_n	13.67 kips-in	<i>Bending moment capacity of the angle</i>	

The procedure for checking this limit state is taken from page 15-10 of the *AISC Steel Design Manual* (equation 15-21). This procedure can also be found in the 3rd edition of *Steel Structures: Design and Behavior*, by Salmon and Johnson. The assumption is that the legs act as a simply supported beam between weld points subjected to a point load at the mid point of the beam. The capacity would be equal to the plastic bending capacity of an equivalent plate.

When the angle connection is bolted and there is axial tension present in the clip angle shear connection, the program will also check that the angle will not fail due to bending. The procedure for this limit state comes from page 15-10 of the AISC 14th edition Steel Design Manual. The program conservatively uses the 14th edition version of this equation for design per both the 13th and 14th edition design manuals. If you have selected a Canadian design code, the procedure from the Salmon and Johnson textbook will be used.

- Note that this limit state is only checked when the clip angle is welded at the vertical edges only. If the clip angle is welded to the supporting element with a L or C shaped weld, we assume that the angle cannot bend so the check is not included.

Bearing Limitation

At this time the program is not considering beam or column bearing per section J1.4(2(i)) or page 14-14, of the AISC 14th edition, respectively.

Bolt Checks

These bolts checks are common to many different connection types.

Bolt Material Options

The following ASTM bolt material designations are available in RISAConnection:

Bolt Designation	AISC 13th Ed.	AISC 14th Ed.	AISC 15th Ed.	AISC 16th Ed.
A307	A307	A307	A307	A307
A325	A325	Group A	Group A	Group 120
A490	A490	Group B	Group B	Group 150
F3043	-	-	Group C	Group 200
F3148	-	-	-	Group 144

Metric bolt sizes are supported for every bolt designation.

The material properties of metric bolts are not exactly equal to the imperial ASTM with the same designation as there is as much as a 0.5% difference between 120 or 150 ksi used in the imperial ASTMs and the 830 or 1035 MPa used in the metric ones.

When bolts are designated with a material property of A325, the bolt strength in the ASTM varies based on the bolt diameter. Bolts up to an inch in diameter have a strength of 120 ksi, larger bolts have a strength of 105 ksi. This is enforced for the CSA S16-09 and the CSA S16-14 codes, but is NOT enforced for the AISC codes. This was ignored for AISC even though it is unconservative. That is because the larger values are given directly in AISC specification table J3.2 without regard to bolt size.

Bolt Group Eccentricity

When bolt groups are subjected to shear loads that are eccentric to the centroid of the bolt group, then bolt group eccentricity is introduced. To account for this eccentricity, the AISC 14th Edition Manual provides two different methods: the Instantaneous Center of Rotation method (IC method) and the Elastic Method. These are given as options in [Global Parameters - Solution](#) tab. Information on these methods are found on pages 7-6 through 7-9 in the AISC 14th edition manual and most steel design textbooks.

Bolt Group Eccentricity		0.3427
IC method		(AISC 14 th p. 7-6)
C	0.3427	Coefficient (2.7415 / 8)
N _{rows}	2	Number of rows of bolts
N _{cols}	4	Number of bolts per row
D _x	3.0000 in	Horizontal bolt spacing
D _y	3.0000 in	Vertical bolt spacing
E _x	11.0000 in	Horizontal eccentricity
E _y	0.4500 in	Vertical eccentricity
Ang	50.1944	Angle of force in degrees, relative X axis
IC _x	-1.2880 in	Center of rotation, X
IC _y	1.4475 in	Center of rotation, Y

The IC method is used to compute the values in Tables 7-7 through 7-14, thus program values can be compared to these tables.

Bolt Group Eccentricity		0.2663
Elastic method		(AISC 14 th p. 7-6)
C	0.2663	Coefficient (2.1303 / 8)
N _{rows}	2	Number of rows of bolts
N _{cols}	4	Number of bolts per row
D _x	3.0000 in	Horizontal bolt spacing
D _y	3.0000 in	Vertical bolt spacing
E _x	11.0000 in	Horizontal eccentricity
E _y	0.4500 in	Vertical eccentricity
Ang	50.1944	Angle of force in degrees, relative X axis

- The E_x value given is the horizontal distance from the face of the supporting member to the centroid of the bolt group.
- The E_y value given is the vertical distance between the centerline of the beam and the centroid of the bolt group.
- The **Ang** value given is the angle between the X axis and the resultant load (resultant of the shear and axial loads).
- Once this coefficient is computed it is used in the [Bolt Shear Strength](#) check.
- Generally the Elastic method is more conservative than the IC method.

Note:

- The shear tabs for moment connections do not consider any eccentricities, thus this section will not be included in these connections. This is because moment connections have the rotational restraint in the flanges, thus not allowing the rotation to occur that is typical in a simple shear connection.

When Eccentricity Can Be Ignored

Both the AISC and CSA codes give parameters when this eccentricity can be ignored for the **Bolt Shear Strength** check. If you wish to ignore the eccentricity when these codes allow for it make sure the Full Shear Ecc. Considered checkbox is unchecked on the [Global Parameters - Solution](#) tab.

AISC 13th Edition (360-05) Double Angle Connections

For double angles that meet this criteria, the bolt group eccentricity coefficient can be ignored (per page 10-8 of manual):

- Standard or short-slotted holes
- Single row of bolts through the web of the supported beam
- Bolts located at workable gages.

AISC 13th Edition (360-05) Shear Tab Connections

For shear tabs that meet this criteria, the bolt group eccentricity coefficient can be ignored (per page 10-102 of manual):

- Standard configuration
- Standard holes for up to 9 bolts
- For standard holes with $n = 10$ to 12 , use $e = n - 4$ and 1.25 factor on C.
- Short-slotted holes for up to 12 bolts

AISC 14th Edition (360-10) Double Angle Connections

For double angles that meet this criteria, the bolt group eccentricity coefficient can be ignored (per page 10-8 of manual):

- Bolts located at gages not exceeding 3"
- Standard or short-slotted holes
- Single row of bolts through the web of the supported beam

AISC 14th Edition (360-10) Shear Tab Connections

For shear tabs that meet the standards of the conventional configuration, Table 10-9 is used.

CSA (S16-09 and S16-14) Double Angle Connections

From page 3-58 of the manual the eccentricity can be ignored for single row of bolts in the web-framing leg. Because the AISC manual is more detailed regarding this the 13th edition criteria are also used here.

CSA (S16-09 and S16-14) Shear Tab Connections

From page 3-70 of the manual there is a discussion of how eccentricity was considered in the following table. Because there is no formal layout of parameters the AISC 13th edition was used.

Slip Critical Considerations

This check is calculated per equation J3-4 of the AISC 360-10 specification. The bolts can be considered slip critical if you select Slip Critical Class A or Class B listed in the Components Bolts section.

The slip critical value is multiplied by the C coefficient determined from the Center of Rotation method or the Elastic method specified in the Global Parameters. See [Bolt Group Eccentricity](#) for more information on the calculation of the C coefficient. This method was taken from the "Design of All-Bolted Extended Double Angle, Single Angle, and Tee Shear Connections" by Perry Green, Thomas Sputo, and Adam Higgins.

Slip Critical calculations are not supported for the CSA S16-09 or the CSA S16-14 design codes.

Strength vs. Serviceability (AISC 360-05)

The program will use serviceability limit state for standard holes (STD) or slots transverse to the direction of load (SSLH, LSLH). The program will select required strength level if the hole is oversized (OVS) or slots are parallel to the direction of the load (SSLV, LSLV).

If the holes are defined with contradicting hole types, the program will use required strength level. For example if the beam bolts use a standard hole, and the attached clip angle uses oversized holes, required strength level will be used.

Combined Tension and Shear

When a slip-critical connection is subjected to a tension load in addition to the shear load, the program will also calculate the k_s factor per section J3.9 and apply this factor to the available slip resistance per equation J3-4.

Axial Loads

If you have applied axial loads (compression or tension) in addition to shear loads, the required load at the beam bolts will be calculated as the resultant force created by the axial load and the shear load. This resultant force (R) will be divided by the available slip critical capacity per equation J3-4 to give the Unity Check value in the results report.

Slip Critical Calculations

Beam Slip Critical		25.0000 kips	17.7111 kips	1.41	FAIL
$R_n = \mu * D_u * h_f * T_b * n_s * N_{rows} * N_{cols} * C$			$\phi = 1.00$	(J3-4)	
μ	0.3000		Mean slip coefficient (class A)		
D_u	1.1300		Min. bolt pretension		
h_f	1.0000		Factor for fillers		
T_b	28.0000 kips		Min. fastener Pretension per Table J3.1		
n_s	1		Number of slip planes		
N_{rows}	2		Number of rows of bolts		
N_{cols}	4		Number of bolts per row		
C	0.2332		Eccentricity coefficient		
ϕR_n	17.7111 kips		Slip critical		

Bolt Shear Strength

This shear capacity check is calculated per section J3.6 (shear only or shear and compression) or J3.7 (combined tension and shear) of the AISC 360-10 specification. Expand this section of the design report and RISACONNECTION will provide you with the exact equation, specification reference, listed variables, as well as the code check value and pass or failure notification.

Shear Connections

Bolt Shear at Beam		25.0000 kips	33.3853 kips	0.75	PASS
$R_n = F_{nv} * A_b * N_{bolt} * C$			$\phi = 0.75$	(J3-1)	
F_{nv}	54.0000 ksi		Shear stress N type		
A_b	0.4418 in ²		Area of bolt		
N_{bolt}	8		Number of bolts		
C	0.2332		Eccentricity coefficient		
ϕR_n	33.3853 kips		Bolt shear rupture strength		

Note:

- The Eccentricity Coefficient, C is calculated in the [Bolt Group Eccentricity](#) check, as explained above.
- If you have applied a compressive axial load in addition to the shear load, the required load at the beam bolts will be calculated per section J3.6 as the resultant force created by the axial load and the shear load. This resultant force (R) will be divided by the available bolt shear capacity per equation J3-1 to give the Unity Check value in the results report.
- If you have applied a tensile axial load in addition to the shear load, the required load at the beam bolts will be calculated per section J3.7 as the resultant force created by the axial load and the shear load. This resultant force (R) will be divided by the available bolt shear capacity per equation J3-2 to give the Unity Check value in the results report.

Moment Connections

If this check is part of a moment connection (End Plate or Flange Plate Moment Connection), the check will also convert the allowable shear strength to an allowable moment and check this against the user input Moment Load.

Bolt Shear at Flange Plate	45.2830 kips	107.3541 kips	0.42	PASS
$R_n = F_{nv} * A_b * N_{bolt} * C$		$\phi = 0.75$ (J3-1)		
F_{nv}	54.0000 ksi	Shear stress N type		
A_b	0.4418 in ²	Area of bolt		
N_{bolt}	6	Number of bolts		
C	1.0000	Eccentricity coefficient		
ϕR_n	107.3541 kips	Bolt shear rupture strength		
d_m	15.9000 in	Moment arm between the flange forces		
R_{req}	45.2830 kips	Required Flange Force (worst) in bolts due to moment		

Note:

- The Eccentricity Coefficient, C is calculated in the [Bolt Group Eccentricity](#) check, as explained above.

Limitation

- The reduction in shear capacity for very long connections as specified in the footnotes of AISC Specification, Table J3.2 is not accounted for, as this is a rare case.

Bolt Tensile Strength

The bolt tensile capacity check is calculated for column or girder bolts in tension per section J3.7 of the AISC 360-10 specification. Expand this section of the design report and RISACONNECTION will provide you with the exact equation, code reference, listed variables, as well as the code check value and pass or failure notification.

Bolt Tension at Column	15.37 kips	29.82 kips	0.52	PASS
$R_n = F_{nt} * A_b$		$\phi = 0.75$ (J3-2)		
Check User Note Limit:	$f_{rt}/(F_{nt} * \phi) \leq 0.3$			
f_{rt}	24.86 ksi	Required tensile stress = $(T_{bolt} - P) / n_b / A_b$		
F_{nt}	90.00 ksi	Nominal tensile stress, per Table J3.2		
Because $f_{rt}/(F_{nt} * \phi) > 0.3$, the Bolt Tensile Check is required				
Check Interaction Limit:	$f_{rv}/(F_{nv} * \phi) \leq 0.3$			
f_{rv}	7.55 ksi	Required shear stress: $f_{rv} = (V / n_b) / A_b$		
F_{nv}	54.00 ksi	Nominal shear stress, per Table J3.2		
Because $f_{rv}/(F_{nv} * \phi) \leq 0.3$, this check shall use the regular F_{nt} stress				
V	20.00 kips	User input shear load		
P	-20.00 kips	User input axial load		
A_b	0.44 in ²	Bolt cross sectional area		
n_b	6	Number of bolts		
T_{bolt}	7.65 kips	Max tension load per bolt due to eccentricity = $0.5 * (6 * M_e / (b * d^2)) * A_t * k_{eff}$		
M_e	103.29 kips-in	Moment due to eccentricity = $(V * e_x) - (P * e_y)$		
e_x	3.23 in	Horizontal eccentricity		
e_y	1.93 in	Vertical eccentricity		
b	3.50 in	Connector width		
d	9.00 in	Connector depth		
A_t	10.50 in ²	Maximum tributary area per bolt		
k_{eff}	0.67	Coefficient correction factor		
T_u	15.37 kips	Required tensile strength (see 'Bolt Prying' check)		
ϕR_n	29.82 kips	Bolt tensile strength		

Applicability Checks

This limit state includes two checks: the *User Note* check which will check the limit per the specification User Note in section J3.7, and the *Interaction Limit* check which sets upper limits on the frv (required shear stress) value. Please reference Figure C-J3.1 in the Commentary for a graphical representation of the limit.

If the User Note check determines that the check is not required, you will see the following result:

Bolt Tension at Column		$\phi = 0.75$ (J3-2)	N/A
$R_n = Fnt * Ab$			
Check User Note Limit:	$frt/(Fnt*\phi) \leq 0.3$		
frt	12.4652 ksi	Required Tensile Stress = $(Tbolt-P/nb)/Ab$	
Fnt	90.0000 ksi	Nominal Tensile Stress, per Table J3.2	
Because $frt/(Fnt*\phi) \leq 0.3$, the Bolt Tensile Check is not required			
Tbolt	3.8403 kips	Max Tensile Load (per bolt) due to eccentricity = $0.5 * (6*Me/(b*d^2))*At*k_{eff}$	
Me	51.8438 kips-in	Moment due to eccentricity = $(V * ex) - (P * ey)$	
V	10.0000 kips	User Input Shear Load	
P	-10.0000 kips	User Input Axial Load	
ex	3.2344 in	Horizontal eccentricity	
ey	1.9500 in	Vertical eccentricity	
Ab	0.4418 in ²	Bolt cross sectional area	
b	3.5000 in	Connector width	
d	9.0000 in	Connector depth	
At	10.5000 in ²	Maximum tributary area per bolt	
nb	6	Number of bolts	
k_eff	0.6667	Coefficient correction factor	

Canadian Code

The Canadian code (CSA S16-09 or CSA S16-14) includes clause 13.12.1.4 to cover cases where bolts are subjected to combined tension and shear. This is listed as a separate check in RISACONNECTION as shown below: .

Bolt Interaction at Column		1.01	FAIL
$(V_f/V_r)^2 + (T_f/T_r)^2 \leq 1$		(clause 13.12.1.4)	
V_r	17.81 kips	Bolt shear strength	
V_f	12.50 kips	Factored shear demand of the bolt	
T_r	31.81 kips	Bolt tension strength	
T_f	22.95 kips	Factored tensile demand of the bolt	
UC	1.01	unity check per interaction equation	

Eccentricities

While any applied moment force is considered to be resisted by the beam flanges and not the bolts themselves, we do account for the moment due to eccentricity in this check. The eccentricities are measured between the center line of the beam and the centroid of the connecting elements, as shown below:

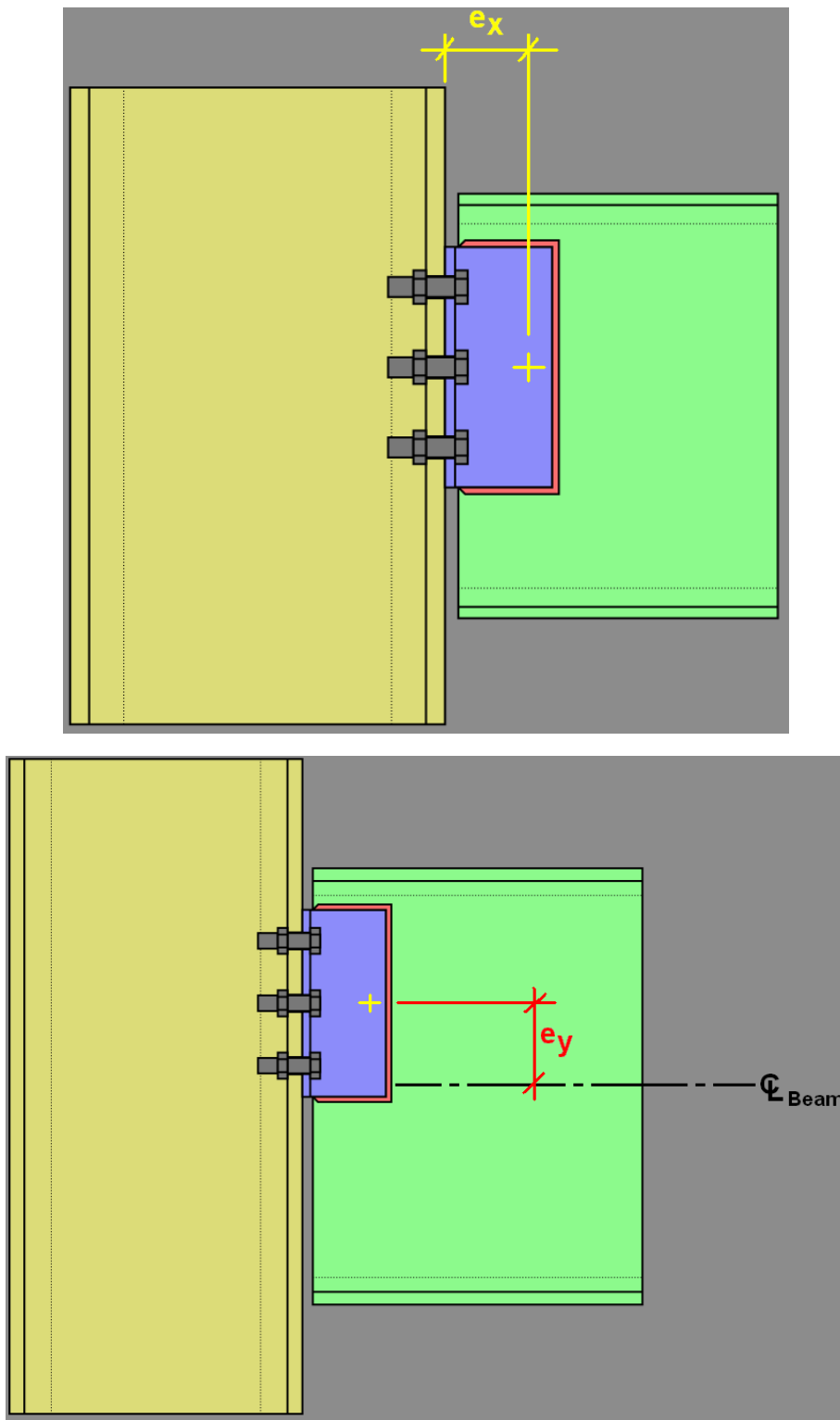

Worst Case Bolt Tension

The procedure for calculating the worst case bolt tension caused by moment due to eccentricity is borrowed from *Steel Structures: Design and Behavior*, 3rd Edition by Salmon and Johnson. In this procedure, the bolt tension due to moment is added to the bolt tension caused by a pure axial force to come up with a total required force.

To calculate the axial load due to moment, we assume that the plate or clip angle acts as a solid rectangular beam in flexure. The flexural stress at the bolt row furthest from the center is then multiplied by the tributary area of the

bolt (A_T). A_T is the maximum tributary area to a bolt at the outer-most layer, please the images below for a graphical image of this area:

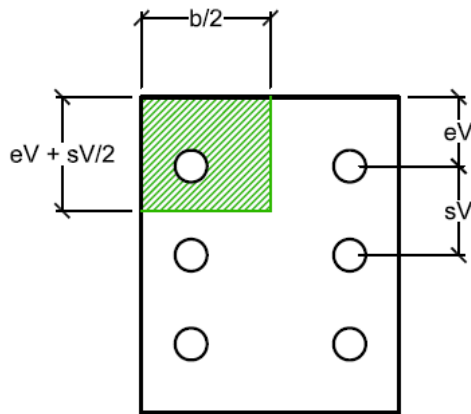

End Plate (1 row of bolts)

$$A_T = (b/2) * (eV + sV/2)$$

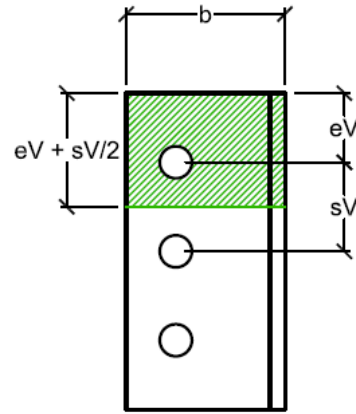

Clip Angle (1 row of bolts)

$$A_T = b * (eV + sV/2)$$

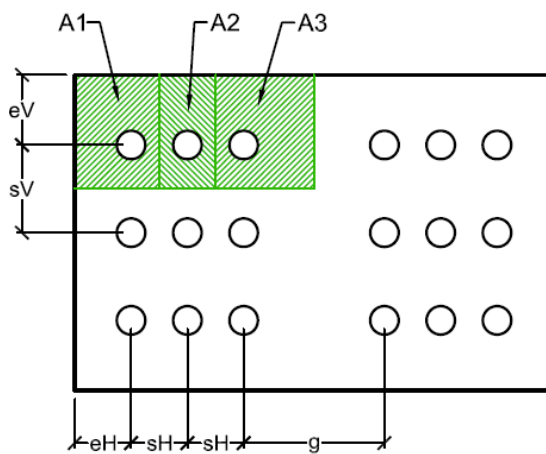

End Plate (Multiple rows of bolts)

$$A1 = (eH + sH/2) * (eV + sV/2)$$

$$A2 = sH * (eV + sV/2)$$

$$A3 = (sH/2 + g/2) * (eV + sV/2)$$

$$A_T = \max(A1, A2, A3)$$

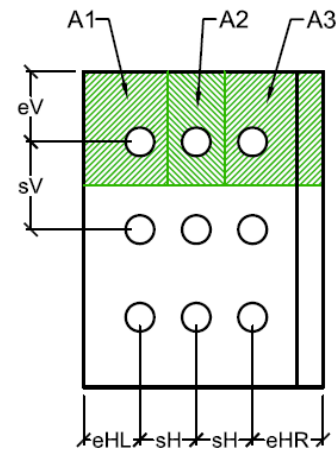

Clip Angle (Multiple rows of bolts)

$$A1 = (eHL + sH/2) * (eV + sV/2)$$

$$A2 = sH * (eV + sV/2)$$

$$A3 = (eHR + sH/2) * (eV + sH/2)$$

$$A_T = \max(A1, A2, A3)$$

Coefficient Correction Factor, k_{eff}

Because our bolts do not connect to the extreme fiber of the connecting plate or clip angle, we use the k_{eff} coefficient to scale back the calculated value of T_{bolt} to be exactly that at the location of the bolt.

Bolt Prying in Shear Connections

The bolt tension check will include bolt prying as long as the Bolt Prying check determines that there are prying forces in the connection. Using the default method, this is determined with the following two checks: minimum

thickness and bolt strength. Alternatively, the effects of prying action can be considered using the alternative method specified on page 9-13 of the AISC 15th Edition Manual.

Default Method

Check #1: Minimum Thickness

The first check compares the thickness of the angle leg or plate to the t_{min} value per equation 9-20 of the AISC 14th Edition Manual.

Bolt Prying		PASS
(AISC 14 th p.9-10)		
Check Angle Leg Thickness:	Pass	Condition: $t_{min} \leq t_{angle}$
t_{angle}	0.3750 in	Clip angle leg thickness
P	-5.0000 kips	User input axial load
F_u	58.0000 ksi	Minimum tensile stress of material
nb	6	Number of bolts
Tbolt	3.1106 kips	Tension Load per bolt due to moment (See 'BoltTension Check')
d_b	0.7500 in	Bolt diameter
d_{hole}	0.8125 in	Bolt hole diameter
b'	1.2500 in	Distance from the inner edge of the bolt hole to the face of the stem, $b' = (b - d_b) / 2$
p	3.0000 in	Length of flange tributary to each bolt along the longitudinal axis of the angle
T	3.9440 kips	Total tension force with moment, $T = Tbolt + (P/nb)$
t_{min}	0.3549 in	Minimum thickness required to eliminate prying action, $t_{min} = ((4 / \phi) * T * b' / (p * F_u))^{0.5}$, $\phi=0.9$

- If the thickness of the connecting element (plate or angle) is more than the t_{min} value, then the first check passes, indicating that prying forces need not be considered. In this case, the second check is not necessary so it will not be included.
- If the thickness of the connecting element is less than the t_{min} value, the first check will fail and the second check will be included to calculate the amount of prying force in the connection. The overall Bolt Prying check will still report as Passing because the prying force will then be included in the Bolt Tension check.

Check #2: Bolt Strength

If required by the first check, the second "check" will calculate the bolt prying force. This prying force is calculated per the equation 9-28 of the AISC 14th Edition Manual. This is then used in the [Bolt Tension](#) check.

Bolt Prying		(AISC 15 th p.9-10)	Prying
Check Angle Leg Thickness:	Prying Considered	Condition: $t_{min} \leq t_{angle}$	
t_{angle}	0.44 in	Clip angle leg thickness	
P	0.00 kips	User input axial load	
F_u	58.00 ksi	Minimum tensile stress of material	
nb	8	Number of bolts	
Tbolt	2.81 kips	Tension Load per bolt due to moment (See 'Bolt Tension Check')	
d_b	0.75 in	Bolt diameter	
d_{hole}	0.81 in	Bolt hole diameter	
b	3.28 in	Distance from bolt centerline to the centerline of angle leg	
b'	2.91 in	Distance from the inner edge of the bolt hole to the centerline of angle leg, $b' = (b - d_b / 2)$	
p	3.00 in	Length of flange tributary to each bolt along the longitudinal axis of the angle	
T	2.81 kips	Total tension force with moment, $T = Tbolt + (P/nb)$	
t_{min}	0.46 in	Minimum thickness required to eliminate prying action, $t_{min} = ((4 / \phi) * T * b' / (p * Fu))^{0.5}$, $\phi=0.9$	
Prying Force:			
a	1.50 in	Distance from bolt centerline to the outer edge of the leg	
a'	1.88 in	Distance from inner edge of bolt hole to the outer edge of the leg, $a' = (a + d_b / 2) \leq (1.25 * b + d_b / 2)$	
ρ	1.55	Ratio of b' to a', $\rho = b' / a'$	
δ	0.73	Ratio of the net area at the bolt line to the gross area at the face of the stem, $\delta = 1 - d_{hole} / p$	
B	29.82 kips	Total tensile capacity per bolt, $B = A_b * F_{nt} * \phi$, $\phi = 0.75$	
t_c	1.49 in	Flange thickness required to develop the available strength of the bolt without prying action, $t_c = ((4 / \phi) * B * b' / (p * Fu))^{0.5}$, $\phi=0.9$	
α	0.12	Ratio of moment at bolt line to moment at stem line, $\alpha = \max [1/\delta [T/B (t_c/t)^2 - 1, 0]$	
q	0.35 kips	Factored prying force per bolt, $q = B [\delta \alpha \rho (t/t_c)^2]$	
Tu	3.17 kips	Total tension on the bolt including the prying force, $Tu = T + q$	

Alternative Method

The AISC Steel Design Manual presents an alternative design approach to bolt prying on page 9-13 (AISC 15th Edition Manual). To use the alternative method, select the **Reduce Avail. Bolt Strength by Prying Effects Factor Q** check-box on the [Solution tab of the \(Global\) Model Settings](#).

This alternative method reduces the available capacity of the bolts by the factor Q which is defined by equations 9-32, 9-33 and 9-34. The appropriate Q equation is dependent on the value of α' which is calculated in the **Bolt Prying** section. The Q equation used is shown at the end of **Bolt Prying** section.

Bolt Prying		N/A
Alternate method		(AISC 14 th p.9-13)
t_{angle}	0.38 in	Clip angle leg thickness
F_u	58.00 ksi	Minimum tensile stress of material
d_b	0.75 in	Bolt diameter
d_{hole}	0.81 in	Bolt hole diameter
b	2.13 in	Distance from bolt centerline to the face of the stem
b'	1.75 in	Distance from the inner edge of the bolt hole to the face of the stem, $b' = (b - d_b) / 2$
p	3.00 in	Length of flange tributary to each bolt along the longitudinal axis of the angle
a	1.50 in	Distance from bolt centerline to the outer edge of the leg
a'	1.88 in	Distance from inner edge of bolt hole to the outer edge of the leg, $a' = (a + d_b / 2) \leq (1.25 * b + d_b / 2)$
ρ	0.93	Ratio of b' to a' , $\rho = b' / a'$
δ	0.73	Ratio of the net area at the bolt line to the gross area at the face of the stem, $\delta = 1 - d_{hole} / p$
B	29.82 kips	Total tensile capacity per bolt, $B = A_b * F_{nt} * \phi$, $\phi = 0.75$
t_c	1.15 in	Flange thickness required to develop the available strength of the bolt without prying action, $t_c = ((4 / \phi) * B * b' / (\rho * F_u))^{0.5}$, $\phi = 0.9$
α'	6.01	Ratio of moment at bolt line to moment at stem line per Eqn (9-35), $\alpha' = 1 / (\delta(1+\rho)) * [(t_c / t_{angle})^2 - 1]$
Q	0.18	Prying effects factor when $\alpha' > 1$ per Eqn (9-34), $Q = (t_{angle} / t_c)^2 * (1 + \delta)$

Factor Q is calculated for 'Bolt Tension' check

Q is then used to reduce the available bolt capacity at the end of the **Bolt Tension at Column** section.

Bolt Tension at Column	11.25 kips	4.03 kips	2.79	FAIL
$R_n = F_{nt} * A_b$		$\phi = 0.75$	(J3-2)	
Check User Note Limit:	$f_{rt} / (F_{nt} * \phi) \leq 0.3$			
f_{rt}	25.46 ksi		Required tensile stress = $(T_{bolt} - P) / (n_b) / A_b$	
F_{nt}	90.00 ksi		Nominal tensile stress, per Table J3.2	
Because $f_{rt} / (F_{nt} * \phi) > 0.3$, the Bolt Tension Check is required				
Check Interaction Limit:	$f_{rv} / (F_{nv} * \phi) \leq 0.3$			
f_{rv}	22.64 ksi		Required shear stress: $f_{rv} = (V / n_b) / A_b$	
F_{nv}	54.00 ksi		Nominal shear stress, per Table J3.2	
Because $f_{rv} / (F_{nv} * \phi) > 0.3$, this check shall use the modified F_{nt} stress				
F'_{nt}	66.70 ksi		Modified nominal tensile stress = $\min(1.3 * F_{nt} - (F_{nt} / (\phi * F_{nv}) * f_{rv}), F_{nt})$	
V	80.00 kips		User input shear load	
P	0.00 kips		User input axial load	
A_b	0.44 in ²		Bolt cross sectional area	
n_b	8		Number of bolts	
T_{bolt}	11.25 kips		Max tension load per bolt due to eccentricity = $0.5 * (6 * M_e / (b * d^2)) * A_t * k_{eff}$	
M_e	240.00 kips-in		Moment due to eccentricity = $(V * e_x) - (P * e_y)$	
e_x	3.00 in		Horizontal eccentricity	
e_y	0.45 in		Vertical eccentricity	
b	4.00 in		Connector width	
d	12.00 in		Connector depth	
A_t	12.00 in ²		Maximum tributary area per bolt	
k_{eff}	0.75		Coefficient correction factor	
T_u	11.25 kips		Total tension force with moment, $T_u = T_{bolt} - P / n_b$	
ϕR_n	22.10 kips		Bolt tensile strength	
Q	0.18		Prying effects factor (see 'Bolt Prying' check)	
T_{avail}	4.03 kips		Available tensile strength including the effects of prying action per Eqn (9-31), $T_{avail} = Q * \phi R_n$	

Note:

- This tensile check does not account for the eccentricity between the axial load in the beam and the centerline of the bolt group on the column/girder. Therefore, all bolts are assumed to share equal amounts of tensile load.

Bolt Bearing Strength

This check is calculated per section J3.10 of the AISC 360-10 specification. Expand this section of the design report and RISACONNECTION will provide you with the exact equations, code reference, listed variables, as well as the code check value and pass or failure notification.

Shear Connections without Axial Loads

Rn_spacing and Rn_edge are taken as the minimum value of the Tear Out and Bearing calculations. These equations are reported in the variable explanation. The spacing variables Lc_edge and Lc-spacing are described below:

$$L_{c_edge} = \text{Bolt Edge Distance} - \left(\frac{\text{Bolt Diameter}}{2} + 1/16'' \right)$$

$$L_{c_spacing} = \text{Bolt Spacing} - (\text{Bolt Diameter} + 1/16'')$$

Note:

- RISACONNECTION considers all three equations in this section (J3-6a through J3-6c) for the Bolt Bearing checks. The program distinguishes between the three equations based on the user input **Bolt Hole Deformation** selection (in the [Solution](#) tab of [Global Parameters](#)) and the **Hole Type** selection in the [Components](#) section of [Connection Properties](#).
- The Bolt Hole Deformation options on the Global Parameters are not available for the Canadian code. When using the Canadian code, the deformation of bolt holes are not considered in the capacity calculations.

Shear Connections with Axial Loads

When axial load is introduced into the connection, the bolt bearing limit state check becomes much more complicated. The direction of the resultant force (axial and shear resultant) affects the direction of the bearing and RISACONNECTION takes this into account when calculating the edge distances.

Bolt Edge Distances

Any given layout of bolts can consist of up to four bolt edge group distances.

- Bolts type A - Corner edge bolts (will be present in all bolted connections)
- Bolts type B - Side edge bolts (will be present in some connections)
- Bolts type C - Bottom edge bolts (will be present in some connections)
- Bolts type D - Inside bolts (only will be present when all other bolt types are present)

Please see the image below for an example of this:

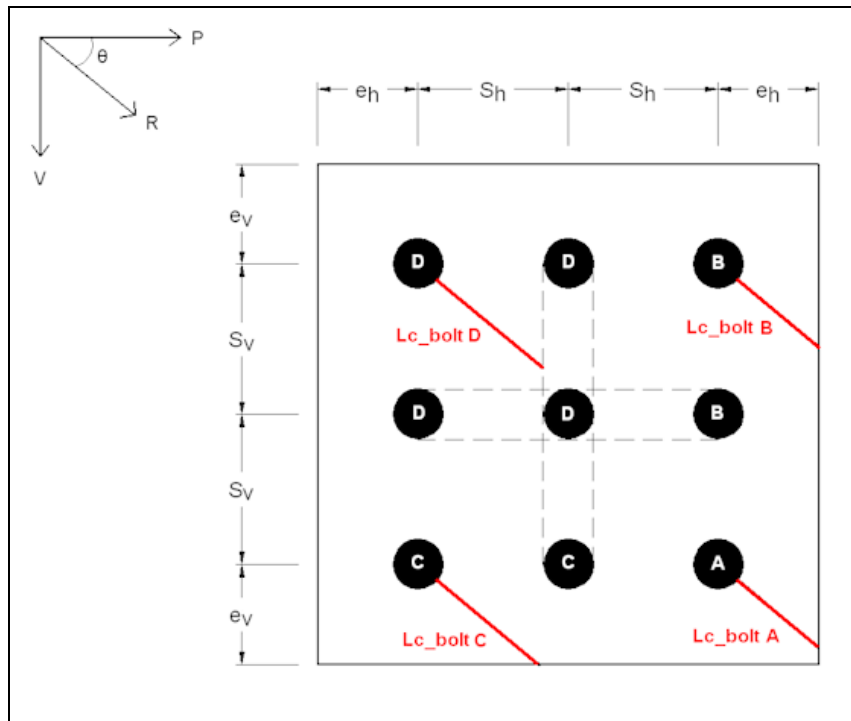

Bolt Hole Diameters

The Bolt Bearing limit state will display three bolt hole diameter values: d_v , d_h , and d . These allow the program to properly calculate edge distances when slotted bolt holes are present.

- d_v is the vertical diameter of the bolt hole
- d_h is the horizontal length of the bolt hole
- d is the distance from the center of the bolt to the edge of the hole in the direction of the bearing force

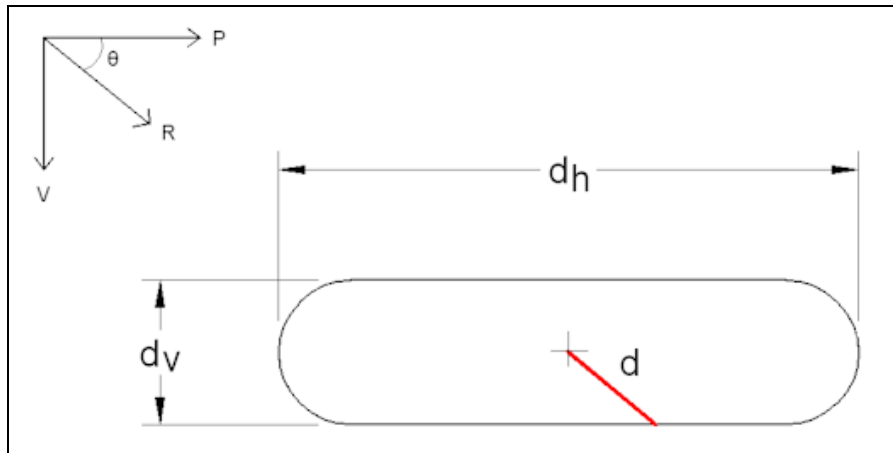

Therefore, if you have a standard bolt hole, $d_h = d_v$ and $d = 0.5 * d_v = 0.5 * d_h$. But if you have a slotted hole, the program will calculate d using the following formula:

$$d = \min\left(\frac{0.5 * d_h}{\sin\theta}, \frac{0.5 * d_v}{\cos\theta}\right)$$

Total Bearing Strength

RISACONNECTION will calculate the individual capacity of each bolt based on their edge distance and then sum them to obtain the total bolt bearing strength.

Note:

- RISACONNECTION considers all three equations in this section (J3-6a through J3-6c) for the Bolt Bearing checks. The program distinguishes between the three equations based on the user input **Bolt Hole Deformation** selection (in the [Solution](#) tab of [Global Parameters](#)) and the **Hole Type** selection in the [Components](#) section of [Connection Properties](#).
- If the connection has slotted holes, it will determine the direction of the bearing force as the direction of the resultant force (axial and shear resultant). If the angle between the resultant force and the horizontal is less than or equal to 45 degrees, the program will assume that the direction of the bearing force is in the direction of the axial force (parallel to the beam). If the angle between the resultant force and the horizontal is more than 45 degrees, the program will assume that the direction of the bearing force is in the direction of the shear force (perpendicular to the beam).
- If you have applied axial loads (compression or tension) in addition to shear loads, the required load at the beam bolts will be calculated as the resultant force created by the axial load and the shear load. This resultant force (R) will be divided by the available bolt bearing capacity per equation J3-6 to give the Unity Check value in the results report.

Moment Connections

If this check is part of a moment connection (End Plate, Flange Plate Moment Connection or Cap Plate Flange Plate Moment Connection), the check will also convert the allowable shear strength to an allowable moment and check this against the user input Moment Load.

Note:

- For Bolted End Plate connections, only the bolts on the compression side of the member are considered effective in resisting shear.
- The edge tear out checks always look at the nearest vertical edge distance for the outside bolts regardless of the direction of the applied shear force. This should always be a conservative assumption.
- For bolt bearing at the cap plate, when the cap plate is in compression, all the bolts at the cap plate will be treated as internal bolts. Since the cap plate extends over the column, the edge distance will be relatively large. Therefore edge distance considerations will not be included when the cap plate is in compression.

Weld Calculations

This topic is specific to welding geometry, base material strengths, weld strengths and all other welding considerations.

Weld Geometry

The weld geometry for each connection is locked by the program. In order to make the connection property inputs easier these geometries may not be altered. The geometries used are industry standard, and illustrated by the AISC.

Double Angle Shear Connection

The weld to support is illustrated in Figure 10-4c of the AISC 14th Edition Manual.

The weld to beam is illustrated in Figure 10-4b of the AISC 14th Edition Manual.

When axial tension is present in the beam, the weld configuration of a single vertical weld on each clip angle (at the support) is inadequate, as that weld would have to resist the tension via torsion in the weld throat. Because no adequate methodology for the torsional strength of weld exists, the program will automatically place a weld on the bottom of the clip angles as well. In addition an [Angle Leg Bending](#) limit state is checked to ensure that the unsupported angle leg doesn't fail in bending due to the axial force.

When multiple Double Angle Shear Connections are grouped together (i.e. multiple connections are part of the same Connection Rule from an integrated RISA-3D model), if *any* connection has an axial tension in its beam for any load combination then *all* of the Connections in that group will receive the L-shaped weld configuration.

End-Plate Shear Connection

The weld to beam is illustrated in Figure 10-6 of the AISC 14th Edition Manual.

When axial tension is present in the beam, the weld configuration of a single vertical weld on each side of the end-plate is inadequate, as those weld would have to resist the tension via torsion in the weld throat. Because no adequate methodology for the torsional strength of weld exists, the program will automatically place a weld on the bottom of the plate as well.

When multiple End-Plate Shear Connections are grouped together (i.e. multiple connections are part of the same Connection Rule from an integrated RISA-3D model), if *any* connection has an axial tension in its beam for any load combination then *all* of the Connections in that group will receive the C-shaped weld configuration.

Shear Tab (Single-Plate) Connection

The weld to support is illustrated in Figure 10-11 of the AISC 14th Edition Manual.

Single Angle Shear Connection

The weld to support is illustrated in Figure 10-13c of the AISC 14th Edition Manual.

The weld to beam is illustrated in Figure 10-13b of the AISC 14th Edition Manual.

Vertical Brace Connections

Vertical Brace Connections consist of a number of sub-connections:

Gusset to Brace

A fillet weld is placed along the entire perimeter of brace/gusset overlap. If an end-weld is not specified by the user then it is not included. The weld can also be specified as balanced.

Gusset to Beam, Gusset to Column

The gusset can be directly welded to the beam/column, or clip angles may be used. When clip angles are specified they are given a C-shaped weld at the beam/column in order to accommodate the significant axial forces that such connections typically experience. See the Double Angle Shear Connection topic above for more explanation on this.

Beam to Column

The beam to column connection is treated as an ordinary shear connection in the program, with one exception. When Double Clip Angle is specified the clip angles receive a C-shaped weld in order to accommodate the significant axial forces that such connections typically experience.

Welds to Face of HSS

Due to the uneven force distribution on welds which are placed on the face of HSS members, an effective weld length is used. This makes certain portions of the weld near the center of the HSS member ineffective, and they are therefore ignored. For more information on this see AISC 360-10, Section K4.

Note:

- For Clip Angle and End Plate Shear Connections with an HSS column the coefficient ($F_y t / F_{yp} t_p$) is always taken as 1.0 since there is no "branch plate thickness" (t_p)
- This reduction in effective weld is not considered for Vertical Brace and Knee Brace connections.

Base Material Strength

Fillet Welds

The base material at the location of a weld may have less strength than the weld itself. In this case it will control the overall strength of the welded connection. In order to account for that the program uses a weld strength reduction factor (α). This factor is included in all Weld Strength calculations where the strength of the connecting element is not directly calculable. The AISC Steel Design Manual presents this as a thickness limitation, but RISACONNECTION has rearranged the equation to the following in order to include it as a reduction factor to the Weld Strength limit state.

$$\alpha = \frac{t \times 0.6F_u}{0.6F_{EXX} \times \frac{\sqrt{2}}{2} \times \frac{D}{16} \times n} \leq 1$$

D = Fillet weld leg size

F_u = Base material rupture strength

n = Number of welds at base material where there is a weld. n=1 corresponds to AISC Eqn 9-2 and n=2 corresponds to AISC Eqn 9-3. For a connection such as a shear tab, this would be 1 because the number of shear rupture areas of the weld is equal to the number of shear rupture areas of the base material.

t = Base material thickness

F_{EXX} = Electrode strength, including reduction factors specified in notes to Table 8-3 on Page 8-65 of the AISC 14th Edition Manual.

α is used as a strength reduction coefficient for the weld strength. This formula is a rearrangement of equation 9-2 of the AISC 14th Edition Manual.

Note:

- An additional 1.5 multiplier is applied to the denominator of the above equation for the flange welds on moment connections (excluding splices). This accounts for the weld's additional strength when loaded in that

direction.

- AISC 360-05 and AISC Design Guide #24 both recommend that the base material strength be checked for both yield and rupture. However, this recommendation was never present in the AISC Manual, and AISC 360-10 specifically omits the requirement to check for yield. Localized yielding of base material is now considered acceptable per AISC. Therefore F_y is not considered in the calculation of α .
- The 0.6 factor on F_u is applicable regardless of the direction of force on the weld. This may lead to a significant difference between the capacity of the base material as calculated in tension (per AISC 360-10, Eqn J4-2) which uses a 1.0 factor on F_u versus the capacity as calculated in the numerator of equation for α . This accounts for the fact that base material failure at a fillet weld is always a shear failure, never a tension failure.
- The user may turn ignore this factor by un-selecting the "[Check Weld Base Mat. Thick](#)" check box on the Solution tab of Global Project Settings.

Partial Joint Penetration (PJP) Welds

The base material proration factor (α) is calculated as shown below:

$$\alpha := \frac{\phi_{base} F_u}{\phi_{weld} 0.60 F_{EXX}} \leq 1.0$$

Φ_{base} = Base Material Strength Reduction Factor per AISC 360-10, Table J2.5

F_u = Base Material Tensile Strength

Φ_{weld} = Weld Material Strength Reduction Factor per AISC 360-10, Table J2.5

F_{EXX} = Electrode strength

Elastic Weld Strength

Welds may be analyzed using an elastic force distribution or an Instantaneous Center of Rotation force distribution method. You can control which method is used through the [Global Parameters](#).

Note:

- Out-of-Plane eccentricity from face of support is ignored for shear connections when a moment connection is also present.

Double Angle Shear Connection

The design of the weld between the angle and the column is complex due to the compression block between the two angles bearing on each other through the beam web. The AISC 14th Edition Manual offers a formula for elastic design of this weld (equation 10-1) which is derived in Blodgett's "Design of Welded Structures" Section 5.4. This formula is used to calculate the weld strength for the double angle to support connection. Out-of-plane eccentricity is ignored.

When axial tension is present in the beam the geometry of the weld is modified as explained in [Weld Geometry](#). Axial compression in the beam is ignored for the weld to the support.

The design of the weld between the angles and the beam uses the procedure detailed on page 8-12 of the AISC 14th Edition Manual. In-Plane eccentricity is taken as the distance between the COG (center of gravity) of the weld group, and the face of the support.

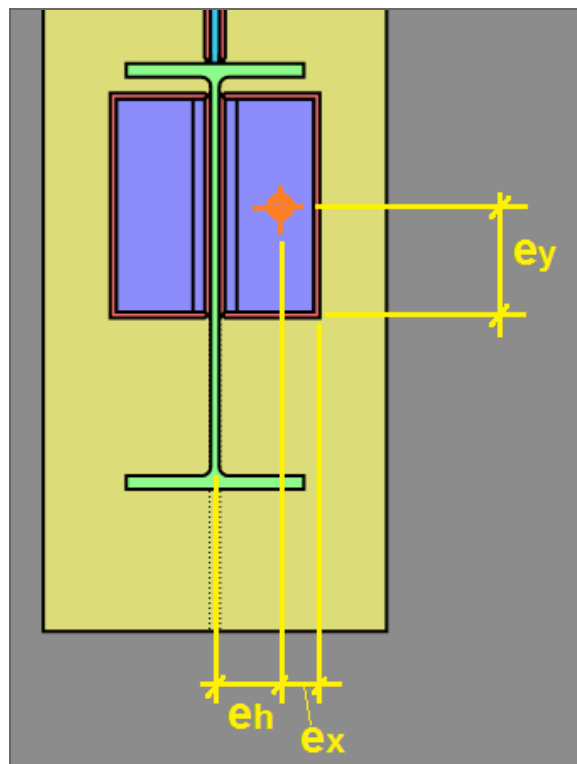

The Polar Moment of Inertia and Section Modulus values are taken from Blodgett's "Design of Welded Structures", Section 7.4.8, Table 5 (C-shaped weld).

$I_p := \frac{(2 \cdot B + L)^3}{12} - \frac{B^2 (B + L)^2}{2 \cdot B + L}$	Polar Moment of Inertia of a C-Shaped Weld, per Blodgett "Design of Welded Structures"
$S_x := B \cdot L + \frac{L^2}{6}$	Strong Axis Section Modulus of a C-Shaped Weld, per Blodgett "Design of Welded Structures"
$S_y := \frac{B^2 (2 \cdot L + B)}{3 \cdot (B + L)}$	Weak Axis Section Modulus of a C-Shaped Weld, per Blodgett "Design of Welded Structures"

Additionally, any rotational moment caused by axial force in the beam is considered, to result in a net rotational stress. The rotational stress is combined with the uniform stresses caused by shear and axial force in the beam, then a resultant is determined using the square root of the sum of the squares.

$$r_u := \sqrt{r_{pu}^2 + r_{mu}^2} \quad \text{Required strength of the total weld for in-plane (beam shear) force}$$

Where:

$$r_{pu} := \frac{V}{L} \quad \text{Shear per ft of weld, AISC 360-10 eqn (8-5a)}$$

$$r_{mu} := \frac{V \cdot e_x \cdot c}{I_p} \quad \text{Shear per ft of weld due to moment, AISC 360-10 eqn (8-8a)}$$

$$r_0 := \left(\frac{M}{S_y} + \frac{P}{L + 2 \cdot B} \right) \quad \text{Required strength of the total weld for out of plane forces (beam tension)}$$

$$r_{3d} := \sqrt{r_u^2 + r_0^2} \quad \text{Resultant force}$$

This resultant stress is compared against the fillet weld strength per AISC Specification equation J2-4, conservatively assuming a load angle (θ) of zero.

End-Plate Shear Connection

The design of the weld between the end-plate and the column is considered to have virtually zero eccentricity, so therefore if no axial loads are present in the beam, the traditional equation for longitudinally loaded fillet welds applies. See AISC Specification equation J2-4. The same applies for the weld between the end-plate and the beam.

When axial tension is present in the beam the geometry of the weld is modified as explained in [Weld Geometry](#). Axial compression in the beam is ignored for all welds.

When axial tension is present in the beam, the out-of-plane uniform and rotational stresses are calculated and combined (r_0). This stress is then combined with the in-plane stress (r_u) caused by the shear load to form a maximum 3-dimensional resultant stress (r_{3d}). This 3-dimensional resultant stress is compared against the fillet weld strength per AISC Specification equation J2-4, conservatively assuming a load angle (θ) of zero.

Note:

- Per the notes of Table 10-4 in the AISC 13th and 14th edition manuals, the effective length of weld, L , equals $L_{plate} - 2 \cdot \text{fillet size}$.
- The above does not apply for Base Plate Columns in tension. Because Base Plates have weak and strong axis shears, the 3-dimensional resultant calculation becomes very complicated. Therefore, Base Plate connections always conservatively ignore the 1.5 factor for combined tension and shear.

Shear Tab Connection

The design of the weld between the shear tab and the support uses the method listed on page 8-12 of the AISC 14th Edition Manual. A polar moment of inertia of $L^3/12$ is used, and the out of plane stress is combined with the in-plane stress using the square root of the sum of the squares. This stress is compared against the fillet weld strength per AISC Specification equation J2-4, conservatively assuming an angle (θ) of zero.

The design of the weld between the shear tab and the beam uses the procedure detailed on page 8-12 of the AISC 14th Edition Manual. In-Plane eccentricity is taken as the distance between the COG (center of gravity) of the weld group, and the face of the support. The polar moment of inertia is taken from Blodgett's "Design of Welded Structures", Section 7.4.8, Table 5 (C-shaped weld). The rotational stress is combined with the shear stress using the square root of the sum of the squares. This stress is compared against the fillet weld strength per AISC Specification equation J2-4, assuming an angle (θ) of zero.

Single Angle Shear Connection

The design of the weld between a single angle and the support uses the procedure detailed on page 8-12 of the AISC 14th Edition Manual. The polar moment of inertia is taken from Blodgett's "Design of Welded Structures", Section 7.4.8, Table 5 (L-shaped weld). The rotational stress is combined with the shear stress, then a resultant is determined using the square root of the sum of the squares. This resultant stress (r_u) is compared against the fillet weld strength per AISC Specification equation J2-4, conservatively assuming an angle (θ) of zero. Out-of-plane eccentricity is ignored.

Axial compression in the beam is ignored for the weld to the support. When axial tension is present in the beam, the program calculates the net out-of-plane tension stress (r_o) at every location along the weld. Net compression stresses are ignored. This out-of-plane stress is combined with the in-plane stress (r_u) using the square root of the sum of the squares to determine the maximum 3-dimensional resultant stress (r_{3d}). This 3-dimensional resultant stress is compared against the fillet weld strength per AISC Specification equation J2-4, conservatively assuming a load angle (θ) of zero. Out-of-plane eccentricity is ignored.

The design of the weld between the angle and the beam uses the procedure detailed on page 8-12 of the AISC 14th Edition Manual. In-Plane eccentricity is taken as the distance between the COG (center of gravity) of the weld group, and the face of the support. The polar moment of inertia is taken from Blodgett's "Design of Welded Structures", Section 7.4.8, Table 5 (C-shaped weld). Additionally, any rotational moment caused by axial force in the beam is considered, to result in a net rotational stress.

The rotational stress is combined with the uniform stresses caused by shear and axial force in the beam, then a resultant is determined using the square root of the sum of the squares. This resultant stress is compared against the fillet weld strength per AISC Specification equation J2-4, conservatively assuming a load angle (θ) of zero.

ICR Weld Strength

Welds may be analyzed using an elastic force distribution or an Instantaneous Center of Rotation force distribution method. You can control which method is used through the [Global Parameters](#). The procedure by which the program calculates the eccentricity coefficient is outlined in the AISC Specification, Section J2.4.

Note:

- Out-of-Plane eccentricity from face of support is ignored for shear connections when a moment connection is also present.
- The eccentricity modification factor (C) is calculated using the analytical procedure (as opposed to being interpolated from tables).

Double Angle Shear Connection

Due to the complexity of the compression block between the two angles bearing on each other through the beam web, there is currently no industry-accepted method of doing an instantaneous center of rotation for the weld between the angles and the support. Therefore, this weld is always designed using the [Elastic method](#), even if Instantaneous Center of Rotation was specified in the [Global Parameters](#).

The design of the weld between the angles and the beam uses the method outlined in section J2.4b of the AISC 360-10 specification. The eccentricity is taken to be in-plane, and is calculated as the distance between the COG (center of gravity) of the weld group and the face of the support. If axial force is present in the beam then it is considered in the calculation of C, and the weld strength is compared against the resultant load.

End-Plate Shear Connection

When axial tension is present in the beam the design of the weld between the beam and the end-plate uses the method outlined in section J2.4b of the AISC 360-10 specification. The eccentricity is taken to be out-of-plane.

For all other circumstances and welds, see [Elastic Weld Strength](#) of end-plate connection.

Shear Tab Connection

The design of the weld between the shear tab and the support uses the method outlined in section J2.4b of the AISC 360-10 specification. The eccentricity is taken to be out-of-plane.

The design of the weld between the shear tab and the beam uses the method outlined in section J2.4b of the AISC 360-10 specification. The eccentricity is taken to be in-plane, and is calculated as the distance between the COG (center of gravity) of the weld group and the face of the support.

Single Angle Shear Connection

The design of the weld between the single angle and the support uses the method outlined in section J2.4b of the AISC 360-10 specification. The eccentricity is taken to be in-plane, and out-of-plane eccentricity from the face of support is ignored. If axial tension is present in the beam then the weld is designed using the [Elastic method](#), even if Instantaneous Center of Rotation was specified in the [Global Parameters](#).

The design of the weld between the angle and the beam uses the method outlined in section J2.4b of the AISC 360-10 specification. The eccentricity is taken to be in-plane, and is calculated as the distance between the COG (center of gravity) of the weld group and the face of the support. If axial force is present in the beam then it is considered in the calculation of C, and the weld strength is compared against the resultant load.

Non-Eccentric Fillet Weld Strength

Some welds have no eccentricity, so they do not need to be designed per [elastic](#) or [ICR](#) methods. These welds are designed using AISC Specification Eqn J2-4. An appropriate value of θ is considered for each weld calculation.

Flange Plate Moment Connections

The weld between the flange plate and the column is considered to have no eccentricity.

Direct Weld Moment Connections

The weld between the flange and the column is considered to have no eccentricity.

Beam to Column Web Moment Connections

RISACONNECTION allows [beam to column web](#) moment connections for the Flange Plate and Direct Weld moment connections. When the beam frames into the column web, the total length of weld at each column inside flange (where the flange plate or transverse stiffener connects) is considered to resist the governing flange force.

The program assumes that only the welds at the column flange resist the flange force, not the weld at the column web. This methodology comes from the article *Moment Connections to Column Webs* by M. Thomas Ferrell in [Modern Steel Construction](#).

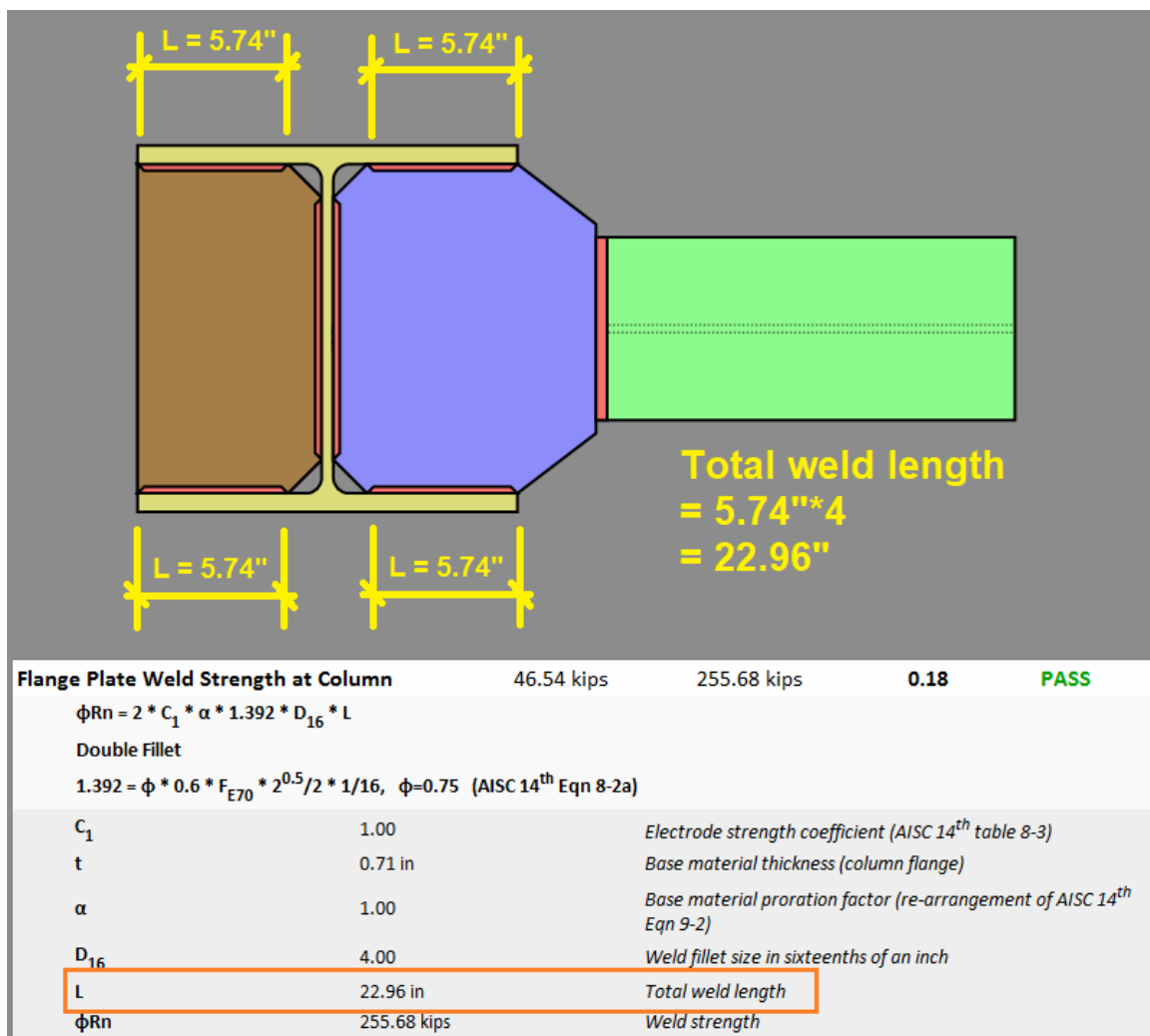

Extended End-Plate Moment Connections

For Extended End Plate moment connections the horizontal fillet distance of the beam (k_1) is not counted for the 'inside' flange fillet welds, as it is impossible to weld in these locations.

If a fillet weld is specified between the beam web and the end plate, it is designed considering the recommendations of AISC Design Guide #4 (2nd Edition) Section 2.1.

This procedure uses an "effective" weld length that is calculated as: $L_{eff} = d/2 - k_{det}$. The weld must also have a minimum size to develop the full tensile capacity of the beam web. This is checked in [Weld Limitations](#).

Splice Connections (Shear and Moment)

Splice connections ignore all eccentricity from both shear and axial loads. When the ICR method is chosen the capacity is calculated using method outlined in section J2.4b of the AISC 360-10 specification. When the Elastic method is chosen the capacity is calculated using the method listed on page 8-12 of the AISC 14th Edition Manual.

Note:

- Weld demand force is taken as zero for flange welds on moment splices which have net compression on both flanges. This is based on the assumption that the welds would not be relied upon to transfer the net compressive force from one member to another.

Vertical Brace Connections

Most eccentricities are ignored for Vertical Brace Connections as they are proportioned per the Uniform Force Method to eliminate all eccentricities.

Gusset to Brace Connection

Per AISC 360-10, Section J1.7, the effects of eccentricity are ignored on this connection.

Gusset to Beam, Gusset to Column

For directly welded connections the axial (transverse) force is neglected on the fillet weld if it results in net compression. Per the AISC 14th Edition Manual, Page 13-11, the weld is designed for a peak stress of 1.25 times the average stress. In other words, a 0.80 reduction factor is applied to the strength. This factor is not given a variable in the code, so RISACONNECTION calls this β . If a double fillet weld is used, the two welds are taken into account in the C coefficient.

For clip angle connections the eccentricity between the axial (transverse) force and the CG of each C-shaped weld, which results in a prying effect, is considered. The eccentricity due to shear (longitudinal) force is ignored.

Beam to Column

This connection is treated the same as a simple shear connection, with the exception of the altered [Weld Geometry](#) on the Double Clip Angle connection. For the Double Clip Angle connection the in-plane eccentricity effects on the weld to support are ignored, as it is assumed that the beam cannot shift vertically to allow the angles to rotate towards each other.

HSS Brace to Cap Plate (Tee Attachment Connection)

Per AISC Design Guide #24, Section 2.1., the 1.5 multiplier for transversely loaded welds is intentionally ignored in this case.

Through-Plate HSS Connections

The eccentricity on through-plate connections is resolved through a force couple, such that no bending occurs on the weld segments. The weld on the "near" end of the connection takes the entire shear due to the beam reaction, as well as a component of the force couple due to eccentricity. The weld on the "far" end of the connection takes the other component of the force couple due to eccentricity. Any axial force in the connection is resisted by both "near" and "far" welds equally.

PJP Weld Strength

PJP (partial joint penetration) welds are sized using an "effective throat". The AISC Specification has requirements for minimum effective throat thicknesses listed in Table J2.3. The program compares the specified effective throat against the thicknesses of the materials, and lists the weld as 'failing' if it does not comply.

The filler metal matching as described for [CJP](#) welds is also checked, however an electrode strength that has less than the matching value is also acceptable, per Table 2.5 from the AISC Specification.

Strength Reduction Factor

The strength reduction factor on PJP welds which are not loaded in pure shear or pure tension is interpolated as an effective factor as shown below:

$$\Phi_{\text{eff}} = \Phi_v + (\Phi_t - \Phi_v)(\sin \theta)^{1.5}$$

Where:

Φ_v = Strength Reduction Factor for PJP Welds in Shear per AISC 360-10, Table J2.5

Φ_t = Strength Reduction Factor for PJP Welds in Tension or Compression per AISC 360-10, Table J2.5

θ = Angle between weld longitudinal axis and resultant load

Moment Connections

For moment connections, the force on the weld is always normal to the weld axis, and is always in tension or compression. The strength of the weld is determined per Eqn J2-3 from the AISC Specification, using the appropriate values from Table J2.5.

Vertical Brace Connections

For vertical brace connections the weld strength is compared against the resultant force regardless of whether the transverse force is a tension or compression. Since AISC 360-10 specifies different strength reduction factors (Φ , Ω) for longitudinal versus transverse loading, RISACONNECTION calculates an effective factor based on interpolation.

Per the AISC 14th Edition Manual, Page 13-11, the weld is designed for a peak stress of 1.25 times the average stress. In other words, a 0.80 reduction factor is applied to the strength.

CJP Weld Strength

CJP (complete joint penetration) welds are designed to develop the full strength of the base material. The metal used for the electrode must "match" the base material metal per the American Welding Society. The program compares the beam, column, and connector materials to the specified weld electrode to determine compatibility. If the materials are not compatible then the weld is considered 'failing'. The most stringent combination of base material/weld electrode is considered.

For an abbreviated list of matching metals, see the AISC Specification J2.6.

Weld Limitations

RISACONNECTION limits welds based on AISC limitations. A warning is provided if the welds violate these limitations.

Beam Weld Limitations			PASS
Weld Max/Min Size, Length		(J2.2b)	
Check Weld Max Size	Pass		
D	0.2500 in	Weld size	
D _{max}	0.3125 in	Max Size Allowed	
t	0.3750 in	Min shelf dimension	
Check Weld Min Size	Pass		
D	0.2500 in	Weld size	
D _{min}	0.1875 in	Min size allowed	
t _{min}	0.2950 in	Controlling member thickness	
Check Weld Min Length	Pass	Condition: $L_{min} \geq 4 * D$	
D	0.2500 in	Weld size	
L _{min}	3.0000 in	Min weld segment length	
Check Weld Max Length	Pass	Condition: $L_{max} \leq 100 * D$	
D	0.2500 in	Weld size	
L _{max}	12.0000 in	Max weld segment length	

Maximum Fillet Weld Size

Fillet welds are limited to a maximum size in order to maintain appropriate shelf dimensions. This is in the AISC specification section J2.2b. For a graphical representation of this requirement see the AISC 14th Edition Manual, figure 8-11. The maximum weld size is checked for the following welds:

- Single and Double Angles welded to support
- Single and Double Angles welded to beam
- End-plate welded to support

Minimum Fillet Weld Size

Fillet welds are limited to a minimum size in order to prevent rapid cooling of the weld, which results in a loss in ductility. This is covered in the AISC Specification, Table J2.4. The limitation is based on the thickness of the thinner part joined. The minimum weld size is checked for all welds.

Minimum Fillet Weld Length

Fillet welds are limited to a minimum length of four times their nominal size. This is covered in the AISC Specification section J2.2b. The minimum weld length is checked for all welds.

Note:

- The weld return shown on single angles welded to a support is ignored for this check.

Maximum Fillet Weld Length

Fillet welds are limited by RISACONNECTION to a maximum length of 100 times their leg dimension. The program is not currently configured to identify "end-loaded" welds, so this is a conservative limitation to avoid Eqn J2-1 from the AISC Specification. The maximum weld length is checked for all welds with a non-zero axial load.

Maximum Flange/Web Thickness

Fillet welds may only be used for Extended End-Plate Moment Connections on beams which have flanges/beams not greater than 3/8" thick. For more information see AISC Design Guide #4 (2nd Edition), page 18.

Weld Constructability

This checks whether the weld will fit where it is attempting to be placed. This is a physical check. For example, if you are welding a 1/4" fillet (leg length) we will check to see if there is 1/4" of space on the member you are welding to. If the weld "falls" off the member you will fail this check.

Beam Web Development

Fillet welds must be sized to develop the full strength of the beam web in tension near the inside bolts for Extended End-Plate Moment Connections. For more information see AISC Design Guide #4 (2nd Edition), page 18.

Effective Throat

See [PJP Weld Strength](#).

Filler Metal Matching

See [CJP Weld Strength](#).

Double-Sided Connections

RISACONNECTION includes the following double-sided connection design per the *AISC 360* and *CSA S16* design codes:

- Beam to Girder Clip Angle Shear
- Beam to Column Web Clip Angle Shear

Note:

- Double-sided moment connections are not available at this time.

Defining the Connection

The double-sided connections may be selected from the Create a New Connection dialog:

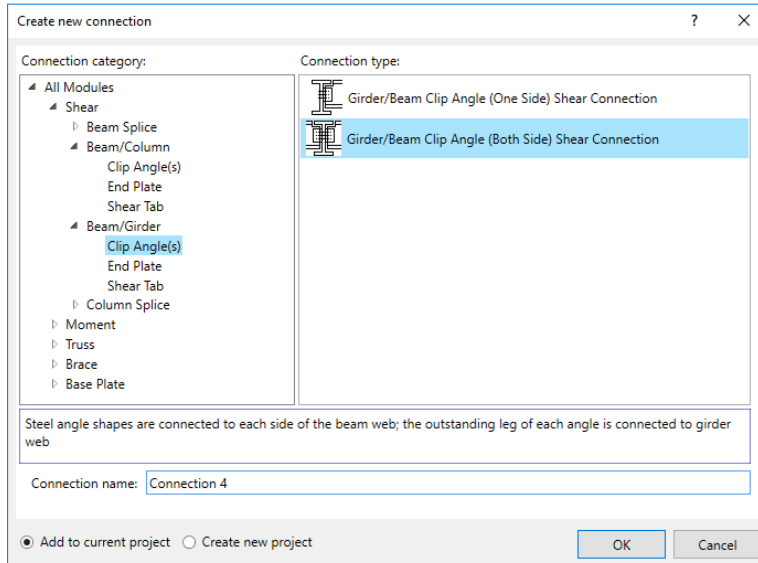
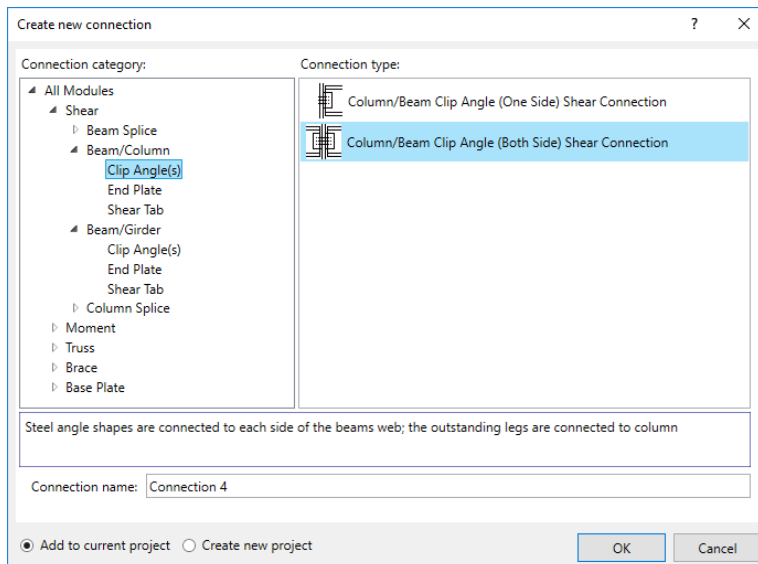

Modeling Directly in RISACONNECTION

It is important to consider what kind of double-sided connection you want to model. Many configurations may be modeled with the single-sided connections in RISACONNECTION because the two sides do not interact. Examples of

this are:

- Double-sided beam connections to column flanges. When the beams are connected to the column flanges, they are not affected by the beam on the other side. Therefore you may model this with two beam to column flange connections.

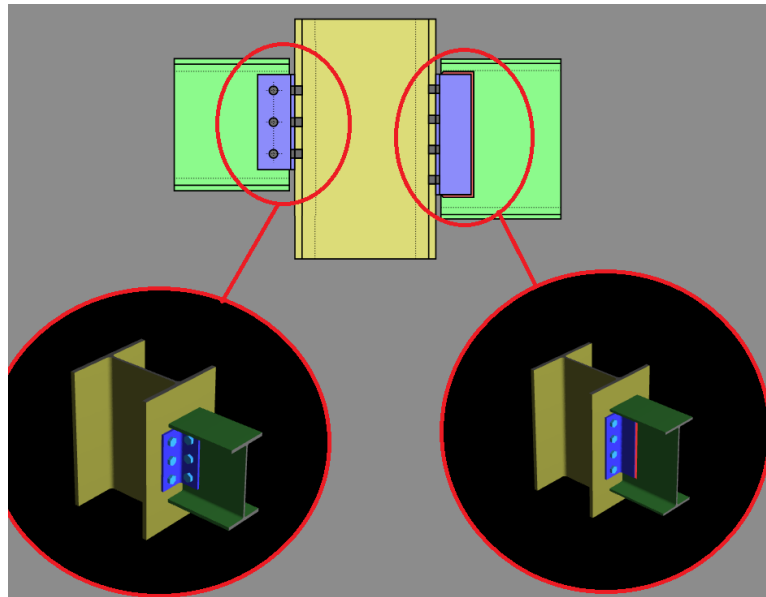

- Double-sided beam connections to a girder web when the beam connectors are single angles. When the beams are connected with equal and opposite facing angles, the two connections do not interact and therefore you may model this with two beam to girder connections.

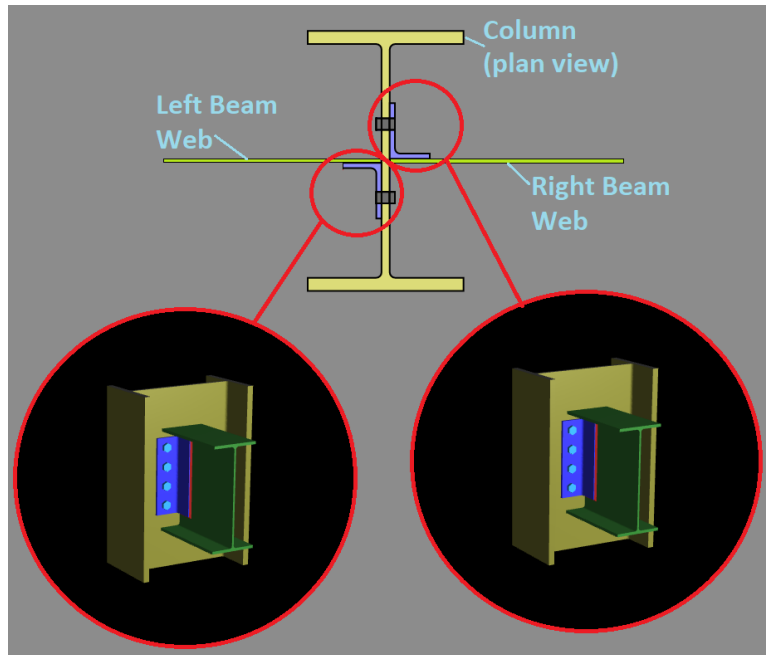

Importing from RISA-3D or RISAFloor

It is important to consider what kind of double-sided connection you want to model. Many configurations may be modeled with the single-sided connections because the two sides do not interact. Examples of this are shown above.

RISA-3D and RISAFloor allow you to designate two sided Column/Beam and Girder/Beam connections when the beam is connected to the Column or Girder web.

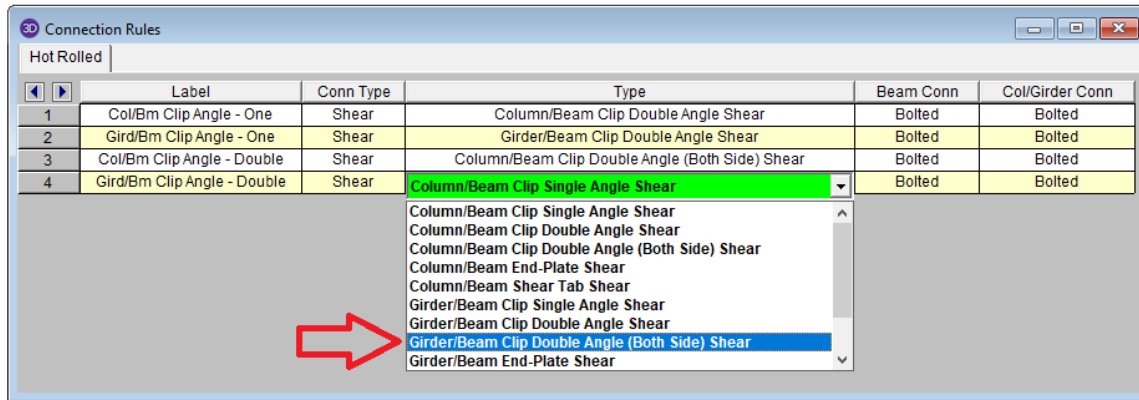

Note:

- This is only available for double clip angle connections.
- Beam center lines may be up to 3" apart for RISA-3D or RISAFloor to consider them in parallel. Anything larger and they will give an error.

Staggered Bolts

You may stagger your bolts at a double-sided connection by setting the **Staggered Connection** entry to either **Left** or **Right**. This selection determines which side (Left or Right) will be staggered downward. This allows the bolts from opposite sides to be staggered into the column or girder web.

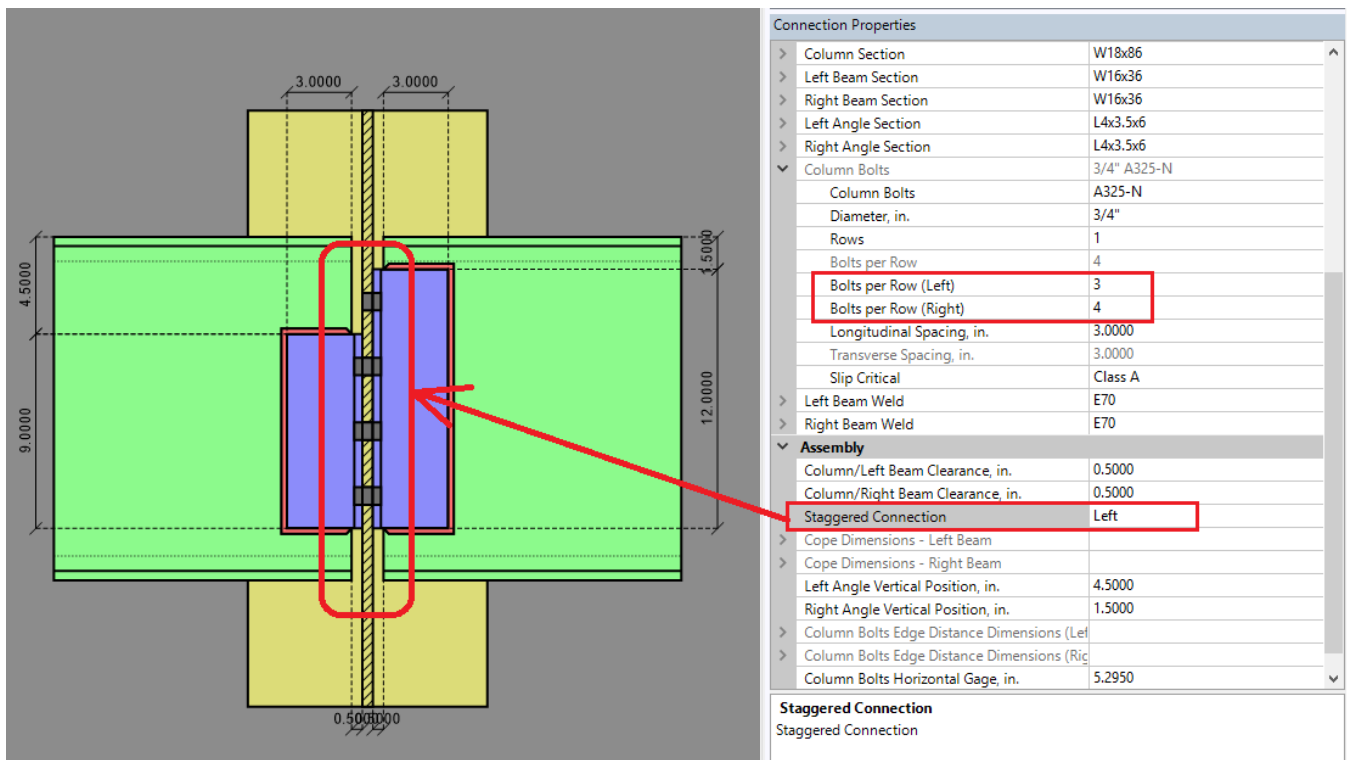

Limit States

Most limit states are unaffected when there is a double-sided connection. The program will include two sets of each check (one for the beam on each side) since they do not interact. The few limit states that are effected by the

connection on the other side are listed below.

Bolt Bearing at the Girder or Column Web

Bolts from both sides will bear on the girder/column web. Therefore the program will now check this limit state on a per bolt basis. The bolt with the maximum shear load will be determined and then this will be checked as the governing bolt.

Bolt Bearing on Column	8.1250 kips	17.8924 kips	0.45	PASS
$R_n = \min(R_{n\text{-spacing-tearout}}, R_{n\text{-bearing}}, R_{n\text{-bolt}})$		$\phi = 0.75$	(J3-6a)	
V_{left}	65.0000 kips	Left beam shear		
V_{right}	0.0000 kips	Right beam shear		
n_{left}	8	Total number of bolts at column (left)		
n_{right}	8	Total number of bolts at column (right)		
V_{bolt}	8.1250 kips	Required governing shear at a bolt, $V_{\text{bolt}} = \max(V_{\text{left}} /n_{\text{left}}, V_{\text{right}} /n_{\text{right}})$		
d	0.7500 in	Bolt diameter		
F_u	65.0000 ksi	Minimum tensile stress of material		
t	0.4800 in	Thickness of material		
$L_{c\text{-spacing}}$	2.1875 in	Horizontal distance from edges of adjacent holes		
$R_{n\text{-bearing}}$	56.1600 kips	Bearing = $2.4 * d * t * F_u$		
$R_{n\text{-spacing-tearout}}$	81.9000 kips	Tear out at spaces = $1.2 * L_{c\text{-spacing}} * t * F_u$		
$R_{n\text{-bolt}}$	23.8565 kips	Bolt shear strength $R_{n\text{-bolt}} = F_{nv} * A_{\text{bolt}}$		
F_{nv}	54.0000 ksi	Nominal shear stress of bolt		
ϕR_n	17.8924 kips	Bolt bearing strength		

Bolt Shear at the Girder or Column Web

Although the bolts can be in double shear (from loading on each side) RISACONNECTION simplifies this into two checks- one at each beam. This is the equivalent as checking the governing bolt in double shear since it takes into account the load from each side individually and is slightly more accurate since the bolts at each side are checked for the exact load on them. If this was combined into a single check, the load would be assumed to be evenly distributed through the bolts on each side which may not truly be the case.

Bolt Shear at Column (Left Beam)	65.0000 kips	143.1388 kips	0.45	PASS
$R_n = 2 * F_{nv} * A_b * N_{\text{bolt}} * C$		$\phi = 0.75$	(J3-1)	
F_{nv}	54.0000 ksi	Shear stress N type		
A_b	0.4418 in ²	Area of bolt		
N_{bolt}	4	Number of bolts		
C	1.0000	Eccentricity coefficient		
ϕR_n	143.1388 kips	Bolt shear rupture strength		
Bolt Shear at Column (Right Beam)	15.0000 kips	143.1388 kips	0.10	PASS
$R_n = 2 * F_{nv} * A_b * N_{\text{bolt}} * C$		$\phi = 0.75$	(J3-1)	
F_{nv}	54.0000 ksi	Shear stress N type		
A_b	0.4418 in ²	Area of bolt		
N_{bolt}	4	Number of bolts		
C	1.0000	Eccentricity coefficient		
ϕR_n	143.1388 kips	Bolt shear rupture strength		

Bolt Tension at the Girder or Column Web

Similar to the Bolt Shear check, the program will check this limit state on each side of the connection separately. The check will determine which bolt governs with the maximum required axial and shear loading, then it will be designed for this governing load.

Bolt Tension at Column (Left beam)	14.7356 kips	25.2251 kips	0.58	PASS
$R_n = F'nt * Ab$		$\phi = 0.75$ (J3-2)		
Check User Note Limit:	$frt/(Fnt*\phi) \leq 0.3$			
frt	20.6901 ksi	<i>Required tensile stress = (Tbolt-P/nb)/Ab</i>		
Fnt	90.0000 ksi	<i>Nominal tensile stress, per Table J3.2</i>		
Because $frt/(Fnt*\phi) > 0.3$, the Bolt Tensile Check is required				
Check Interaction Limit:	$frv/(Fnv*\phi) \leq 0.3$			
V_{left}	8.1250 kips	<i>Shear load per bolt on left side</i>		
V_{right}	1.8750 kips	<i>Shear load per bolt on right side</i>		
V_{max}	8.1250 kips	<i>Maximum shear load per bolt, $V_{max} = \max(V_{left}, V_{right})$</i>		
frv	18.3912 ksi	<i>Required shear stress: $frv = V_{max}/Ab$</i>		
Fnv	54.0000 ksi	<i>Nominal shear stress, per Table J3.2</i>		
Because $frv/(Fnv*\phi) > 0.3$, this check shall use the modified F'nt stress				
F'nt	76.1306 ksi	<i>Modified nominal tensile stress = $\min(1.3*Fnt - (Fnt/(\phi*Fnv)*frv), Fnt)$</i>		
V	65.0000 kips	<i>User input shear load</i>		
P	0.0000 kips	<i>User input axial load</i>		
Ab	0.4418 in ²	<i>Bolt cross sectional area</i>		
nb	8	<i>Number of bolts</i>		
Tbolt	9.1406 kips	<i>Max tension load per bolt due to eccentricity = $0.5 * (6*Me/(b*d^2))*At*k_{eff}$</i>		
Me	195.0000 kips-in	<i>Moment due to eccentricity = $(V * ex) - (P * ey)$</i>		
ex	3.0000 in	<i>Horizontal eccentricity</i>		
ey	0.4500 in	<i>Vertical eccentricity</i>		
b	4.0000 in	<i>Connector width</i>		
d	12.0000 in	<i>Connector depth</i>		
At	12.0000 in ²	<i>Maximum tributary area per bolt</i>		
k_{eff}	0.7500	<i>Coefficient correction factor</i>		
T_u	14.7356 kips	<i>Required tensile strength including prying (see 'Bolt Prying' check)</i>		
ϕR_n	25.2251 kips	<i>Bolt tensile strength</i>		

Bolt Slip Critical at the Girder or Column Web

Similar to the Bolt Bearing check, this will be combined into one check at the supporting column or girder web. The program will determine the governing shear in any bolt at the connection and then check this limit state against that governing load.

Bolt Slip Critical at Column	5.8333 kips	9.4920 kips	0.61	PASS
$R_n = \mu * D_u * h_f * T_b * n_s * C$		$\phi = 1.00$ (J3-4)		
V_{left}	35.0000 kips	Left beam shear		
V_{right}	15.0000 kips	Right beam shear		
n_{left}	6	Total number of bolts at column (left)		
n_{right}	8	Total number of bolts at column (right)		
V_{bolt}	5.8333 kips	Required governing shear at a bolt, $V_{bolt} = \max(V_{left} /n_{left}, V_{right} /n_{right})$		
μ	0.3000	Mean slip coefficient (class A)		
D_u	1.1300	Min. bolt pretension		
h_f	1.0000	Factor for fillers		
T_b	28.0000 kips	Min. fastener Pretension per Table J3.1		
N_s	1	Number of slip planes		
C	1.0000	Eccentricity coefficient		
ϕR_n	9.4920 kips	Slip critical		

Results Report

Because there are so many repeated checks, the results report is broken into several tabs for double-sided connections. A summary of the governing result on each tab is displayed on the **Summary** tab.

Connection View for Connection 3

Summary | Girder Connection | Left Beam Connection | Right Beam Connection | Members | Components

RISA Connection 3 LRFD
Girder/Beam Double Angle (Both Side) Shear Connection
Summary

Material Properties:

Girder	W24x55	A992	$F_y = 50.0000$ ksi	$F_u = 65.0000$ ksi
Left Beam	W16x36	A992	$F_y = 50.0000$ ksi	$F_u = 65.0000$ ksi
Right Beam	W16x36	A992	$F_y = 50.0000$ ksi	$F_u = 65.0000$ ksi
Left Angle	L4x3.5x6	A36	$F_y = 36.0000$ ksi	$F_u = 58.0000$ ksi
Right Angle	L4x3.5x6	A36	$F_y = 36.0000$ ksi	$F_u = 58.0000$ ksi

Input Data:

Left Beam Shear Load	80.0000 kips	User Input Shear Load
Left Beam Axial Load	0.0000 kips	User Input Axial Force
Right Beam Shear Load	80.0000 kips	User Input Shear Load
Right Beam Axial Load	0.0000 kips	User Input Axial Force

Note: Unless specified, all code references are from AISC 360-10

Connection	Controlling Limit State	Max Unity Check	Result
Girder connection	Bolt Bearing on Girder	1.12	FAIL
Left beam Connection	Left Beam Shear Rupture	0.62	PASS
Right Beam Connection	Right Beam Shear Rupture	0.62	PASS

- The limit states for the right beam to right beam connector are checked on the **Right Beam Connection** tab.
- The limit states for the left beam to left beam connector are checked on the **Left Beam Connection** tab.
- The limit states for both connectors to the column web are checked on the **Column Connection** tab (applicable to column supported connections only).

- The limit states for both connectors to the girder web are checked on the **Girder Connection** tab (applicable to girder supported connections only).

Skewed Connections

This topic is specific to skewed shear tabs connections and serves to clarify specifics area of this connection that differ from an orthogonal shear tab connection. Most of the limit states are the same as the traditional, orthogonal shear tab connection however there are some areas that are different. This section will expand and shed light on these areas.

Geometry Input and Considerations

Beams connected to a girder or column can be skewed horizontally to the left or right. To create a skewed connection choose whether to skew the beam to the left or right within the Connection Category subsection in the **Beam Skew from Horizontal** option. If you click the small carot to the left of this option, this will allow you to expand this section to input a **Beam Skew Angle**.

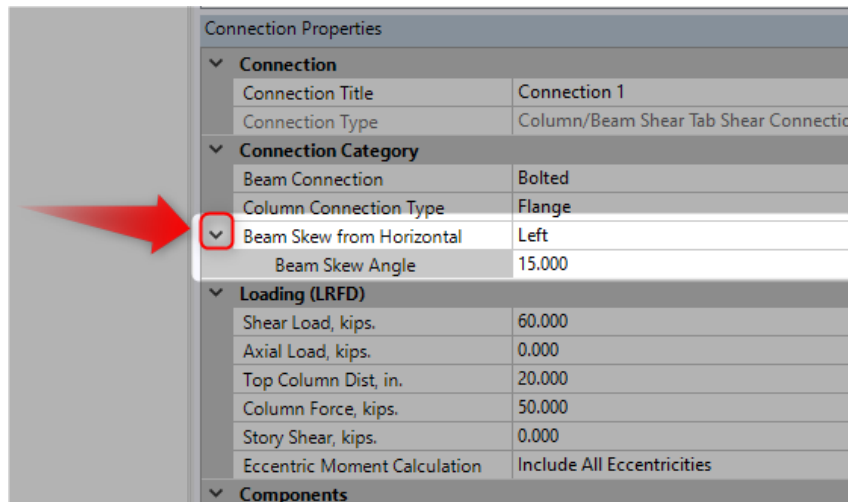

For Column-to-Beam connections, the skew angle is measured from the column centroid to beam centroid.

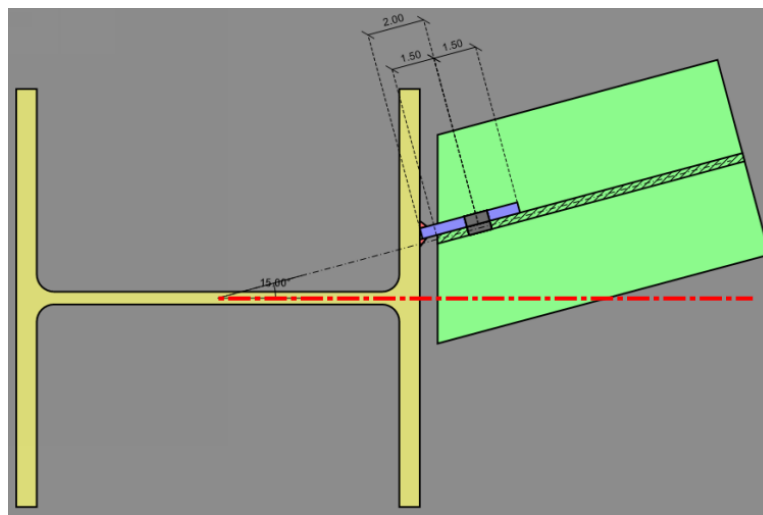

For Girder-to-Beam connections, the skew angle is measured from a perpendicular line from the girder.

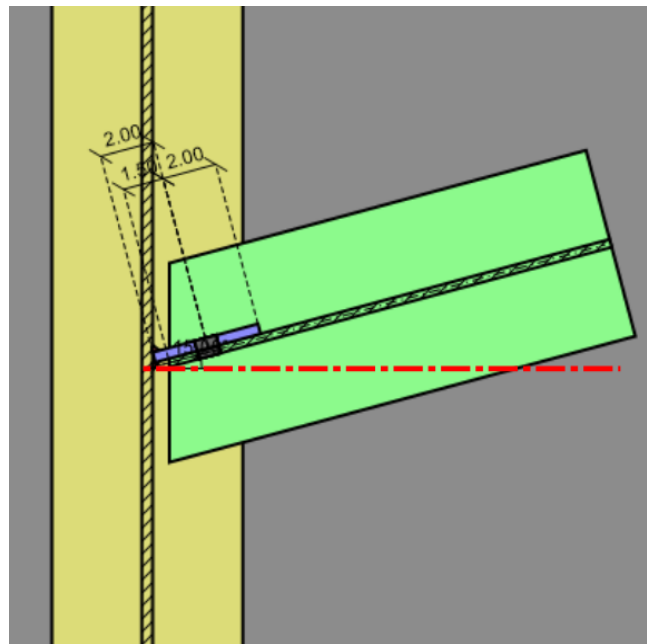
**Limitations:**

- The maximum beam skew angle allowed is **45 degrees**
- The beam will always start outside of the WF column flanges
- Shear tab can only be placed on the back of channel shape beams

Coping Considerations

When coping a beam for a Girder/Beam Shear Tab Shear Connection, the parameter 'e' is measured from the face of the cope at the beam to where the centerline of the shear tab intersects with the girder web.

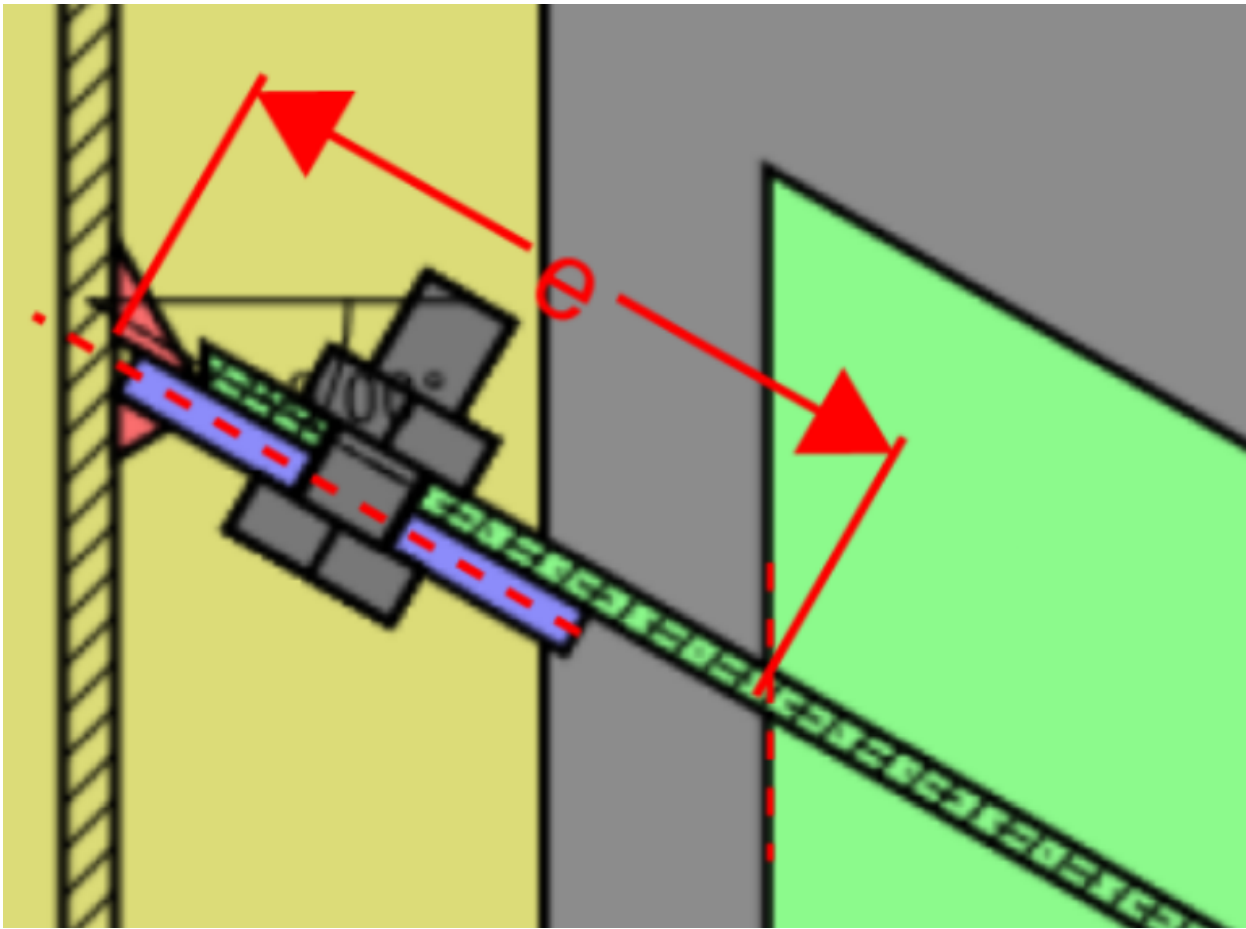

Limitations:

- Beams that frame into columns will not be able to be coped.

Weld Geometry

When configuring a skewed connection you will have the option to input an acute fillet size and an obtuse fillet size.

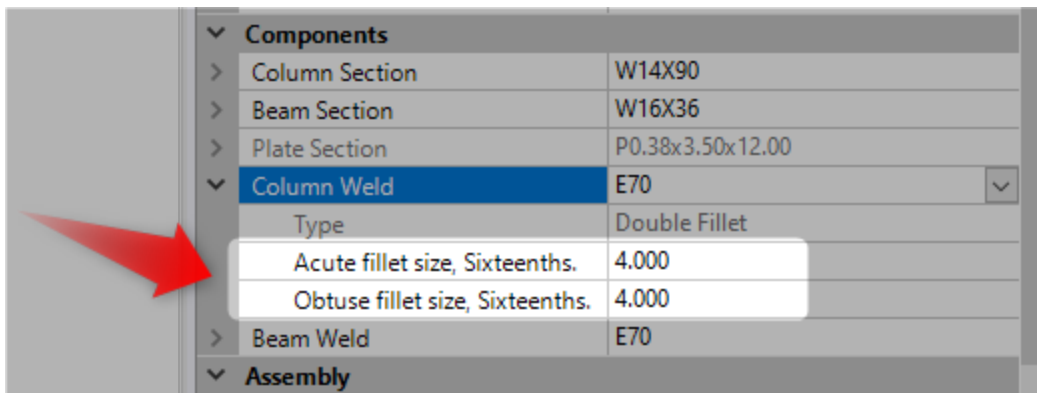

The weld leg size is the parameter that is used to define the weld size on both the acute and obtuse fillet size.

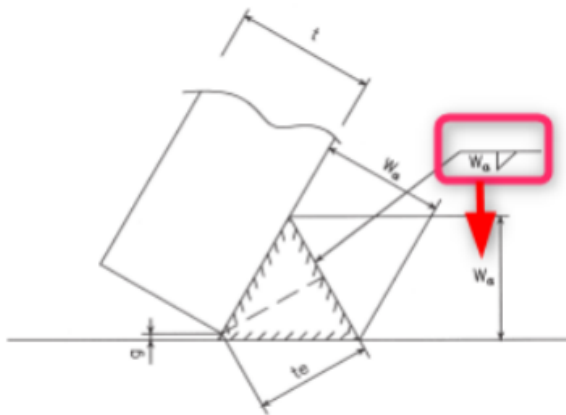

Fig. 15A. Geometry of skewed fillet weld acute side.

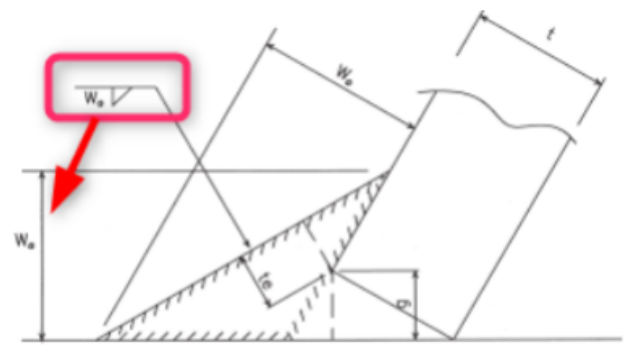

Fig. 15B. Geometry of skewed fillet weld obtuse side.

Loading Considerations

Required Axial Loading for Skewed Connections

The required load taken for the following column checks is taken as the beam axial load multiplied by $\cos(\text{beam skew angle})$:

- Column Web Yielding
- Column Web Crippling
- Column Web Punching Shear
- Column Web Axial Yielding
- HSS Transverse Plastification (13th and 14th ed)
- HSS Column Transverse Plastification (15th ed)

The program will only consider the out-of-plane component of the axial force on the column. In the figure below this corresponds to the F_x force vector.

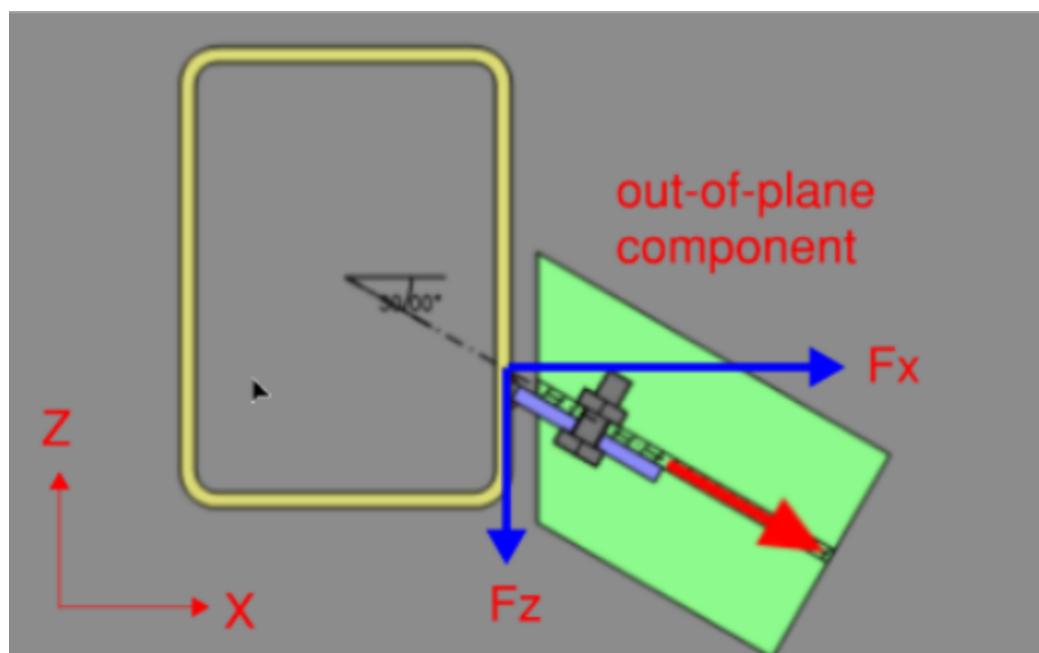

The reason for this is that due to the 45 degree maximum skew limit, the in-plane force F_z will always be less than the out-of-plane force F_x . Secondly, the HSS wall or WF web capacity will always be stronger in the in-plane direction which is why the program focuses on the out-of-plane direction.

Design Considerations

The weld geometry for each connection is locked by the program. In order to make the connection property inputs easier these geometries may not be altered. The geometries used are industry standard, and illustrated by the AISC.

Beam Axial Yield and Beam Tension Rupture

Beam Axial Yield	10.00 kips	477.00 kips	0.02	PASS
$R_n = F_y * A_g$		$\phi = 0.90$ (I4-1)		
F_y	50.00 ksi	<i>Minimum yield stress of material</i>		
A_g	10.60 in ²	<i>Gross area subject to tension (for beveled beam, the cross-section is taken at the last line of bolts or weld)</i>		
ϕR_n	477.00 kips	<i>Tensile yield strength</i>		

Beam Tension Rupture	10.00 kips	466.42 kips	0.02	PASS
$R_n = F_u * A_n$		$\phi = 0.75$ (I4-2)		
F_u	65.00 ksi	<i>Minimum tensile stress of material</i>		
A_n	9.57 in ²	<i>Net area subject to tension (for beveled beam, the cross-section is taken at the last line of bolts or weld)</i>		
ϕR_n	466.42 kips	<i>Tensile rupture strength</i>		

For the **Beam Axial Yield** and **Beam Tension Rupture** checks, the gross and net area of the section is taken at the last line of bolts.

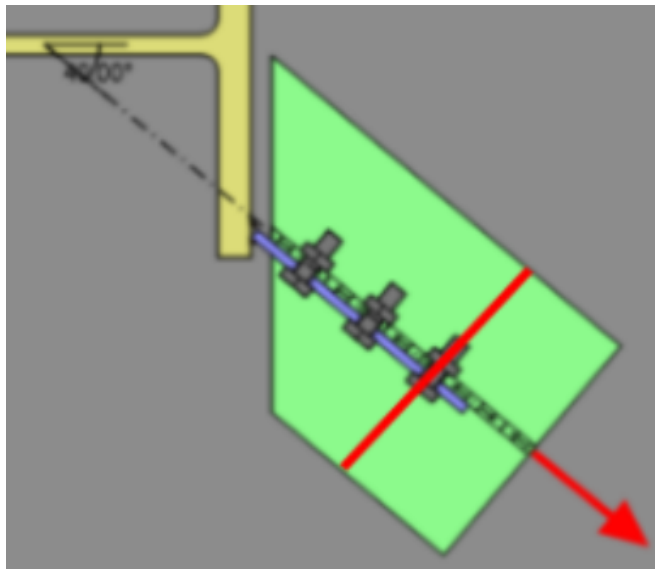

This is due to a few reasons:

- this is where the maximum tension force will occur
- for the section to fail at an intermediate bolt would require the shear tab to break first and this failure is considered in the shear tab limit state checks

- Due to the maximum beam skew angle limitation, the ratio of the load delivered to the row of bolts closest to the column or girder compared to their capacity will never govern the design

HSS Column Transverse Plastification

The parameters a and b are the same as the orthogonal configuration. Typically the parameter, c, used in the HCTP check is taken as the thickness of the plate (tp) for orthogonal connections, but for skewed connections, the parameter c is taken as $tp/\cos(\theta)$ (where θ is the beam skew angle). This is the case for when the plate is beveled and not beveled because eventually the contact area will be the same if the plate is punching into the column web.

Weak Axis Moment Due to Eccentricity for Skewed Connections

Column Weak Axis Moment	12.15 kips-ft	n/a
$M_{\text{weak axis}} = V * e_{x_{\text{weak}}} - P_{\text{weak}} * e_{y}$		
V	60.00 kips	Beam shear load
P_{weak}	0.00 kips	Beam axial load (component normal to column web)
e_{x_{weak}}	2.43 in	Distance from center of bolt group to column centroidal weak axis
e_y	0.45 in	Vertical distance from center of weld to center of beam
M_{weak axis}	12.15 kips-ft	Weak axis moment demand
The column weak axis moment is provided for reference only		
The column design should be checked for the additional weak axis moment		

When the beam is aligned to the column centroid but skewed, an additional eccentricity is produced that causes a moment about the column weak axis. RISACONNECTION will not check the column for this additional weak axis moment but it will report this moment for the designer to consider. This weak axis moment is calculated per direction from an AISC publication called “**Design of Skewed Connections**” by Kloiber and Thornton. The article notes that the column should be checked for this additional moment but in many cases, the other members framing into the column may provide enough restraint to offset the moment.

The following figures below delineates pictorially each of the terms used in the calculation. The weak axis moment calculation can be broken into two pieces: (1) moment due to axial force and (2) moment due to shear force.

For a typical orthogonal shear tab connection the eccentricities e_x and e_y are shown below:

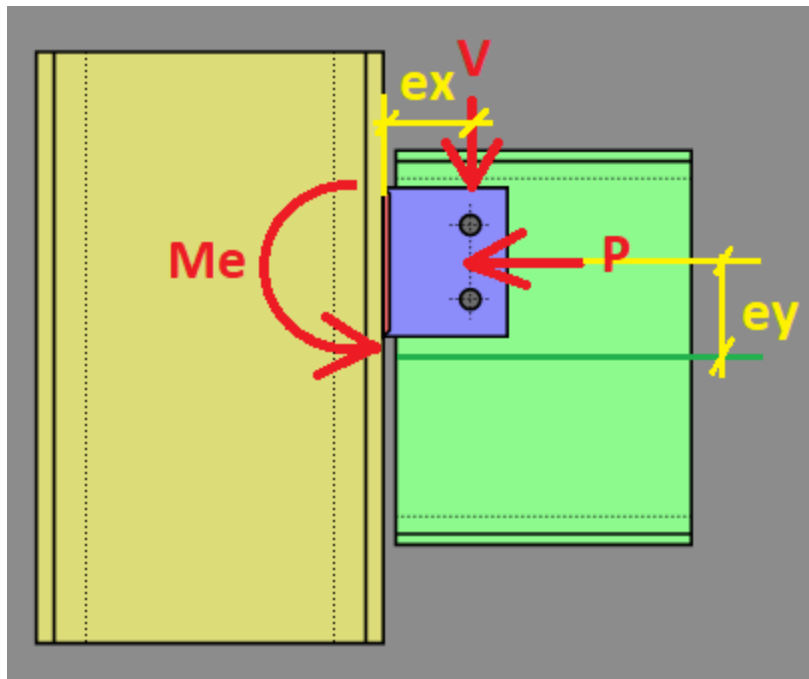

For a skewed connection the moment about the weak axis of the column is determined by taking the component of the axial force in the weak direction of the column (P_{weak}) and multiplying by the ey eccentricity (as shown above).

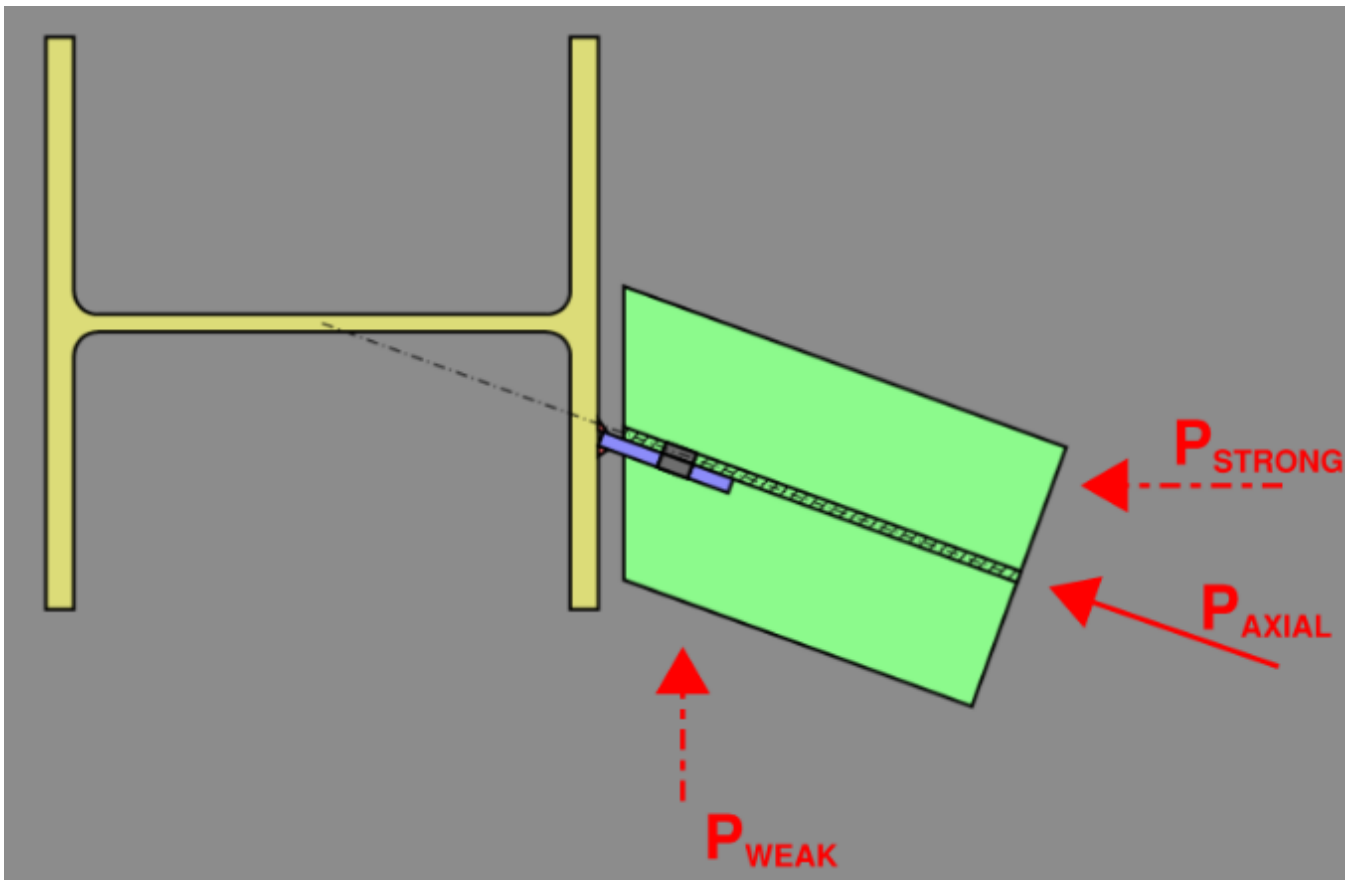

The shear contribution to the weak axis moment is taken by multiplying the shear load by the distance from bolts to centroid of column section. This distance is denoted as ex_{weak} . This distance is measured from the centroid of the column to:

- the first line of bolts (for bolted beam web connections using the AISC 13th edition)
- the center of the bolt group (for the 14th and 15th editions).
- the center of weld group

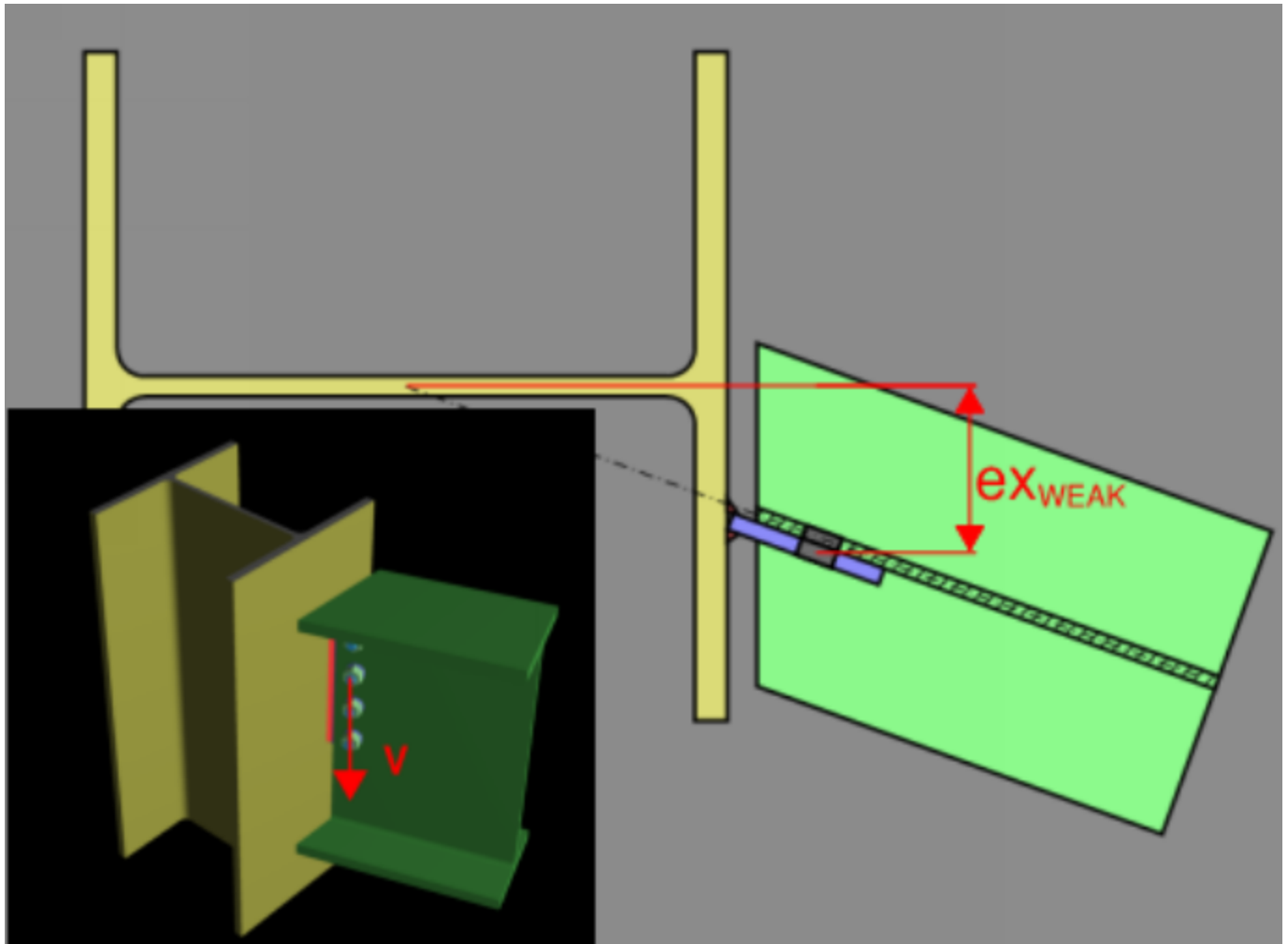

Minimum Weld Size

The minimum effective throat is based on AISC Table J2.4. Since the connection is skewed and the minimum values in the table are based on an orthogonal case, the program takes the minimum weld size from the table and determines the corresponding minimum effective throat to apply to a skewed case.

Note:

AISC recommends the weld to be sized as $(\frac{5}{8})t_p$ to develop the full capacity of the plate (see page 10-102). The program will not automatically do this since this is a recommendation.

Skewed Weld Strength

The weld strength of the skewed angle connections are given by the following equation:

$$\phi R_n = c_1 \cdot \alpha \cdot \phi \cdot 0.6 \cdot F_{E70} \cdot (t_{e1} + t_{e2})$$

Where t_{e1} is the effective throat of the acute side weld and t_{e2} is the effective throat of the obtuse side weld. The effective throat for each case can be found using basic geometric principles. These geometric formulations are presented below:

$$t_{e1} = \frac{1}{16} \cdot \frac{D1}{\cos \theta} \cdot \sin \frac{90 + \theta}{2}$$

$$t_{e2} = \frac{1}{16} \cdot \frac{D2}{\cos \theta} \cdot \sin \frac{90 - \theta}{2} \quad (\text{for Bevel Plate Yes})$$

$$= \left(\frac{1}{16} \cdot \frac{D2}{\cos \theta} - t_p \cdot \tan \theta \right) \cdot \sin \frac{90 - \theta}{2} \quad (\text{for Bevel Plate No})$$

Design Code Limitations

- Canadian design codes are currently unsupported for skewed connections

Misc Design Considerations

- The distance "L" used in the KL/r check is the same for when the plate is beveled or not beveled. This distance is measured from centerline of the bolt group or end of weld to where the centerline of the shear tab intersects with the flange or web.
- Bevel check requirements are per AWS D1.1.5.22.1
- Only double fillet weld type is allowed for skewed connections
- The skewed configuration assumes the extended shear tab configuration

Coped Beam Checks

These checks are specifically for coped beams. The checks apply under the following conditions:

- [Coped Beam Flexural Rupture](#) - applies to all coped beams
- [Coped Beam Web Local Buckling](#) - applies to beams that are coped only at the top flange
- [Coped Beam Lateral Torsional Buckling](#) - applies to beams that are coped at both flanges

Calculation of S_{net} (Net Section Modulus)

The Net Section Modulus is used in most of the strength calculations for coped beams. These are calculated automatically by the program based on the beam section properties and the depth and length of the cope as specified in the Assembly portion of the Connection Properties grid. These calculations should closely match the values reported in AISC 14th Edition Manual Table 9-2.

Flexural Rupture Strength

The nominal Flexural Rupture Strength of the member is determined by multiplying the ultimate stress of the beam material by the net section modulus of the member. Since rupture is a less ductile failure mode, a phi factor of 0.75 and an Omega of 2.0 are used to determine the design strength for this failure state.

Coped Beam Flexural Rupture	60.0000 kips	213.7878 kips	0.28	PASS
$R_n = F_u * S_{net} / e$		$\phi = 0.75$	(AISC 14 th Eq. 9-6)	
F_u	65.0000 ksi	<i>Minimum tensile stress of material</i>		
S_{net}	16.6974 in ³	$S_{net} = I_n / Y_{max}$ <i>elastic section modulus of the cross section</i>		
e	3.8075 in	<i>Distance from the face of the cope to the point of inflection</i>		
I_n	172.1075 in ⁴	<i>Moment of inertia with respect to the neutral axis</i>		
Y_{max}	10.3075 in	<i>Maximum distance from the neutral plane</i>		
h_o	14.8900 in	<i>Overall depth of coped section</i>		
Y_c	3.3675 in	<i>Position of the neutral plane</i>		
ϕR_n	213.7878 kips	<i>Coped beam flexural rupture</i>		

The geometric variables include:

- S_{net} - see [Calculation of \$S_{net}\$ \(Net Section Modulus\)](#) above.
- e - The distance from the face of the cope to the point of inflection. In accordance with Figure 9-2 in the AISC 360-10 (14th Edition), RISACONNECTION takes this conservatively to the far edge of the shear plate.

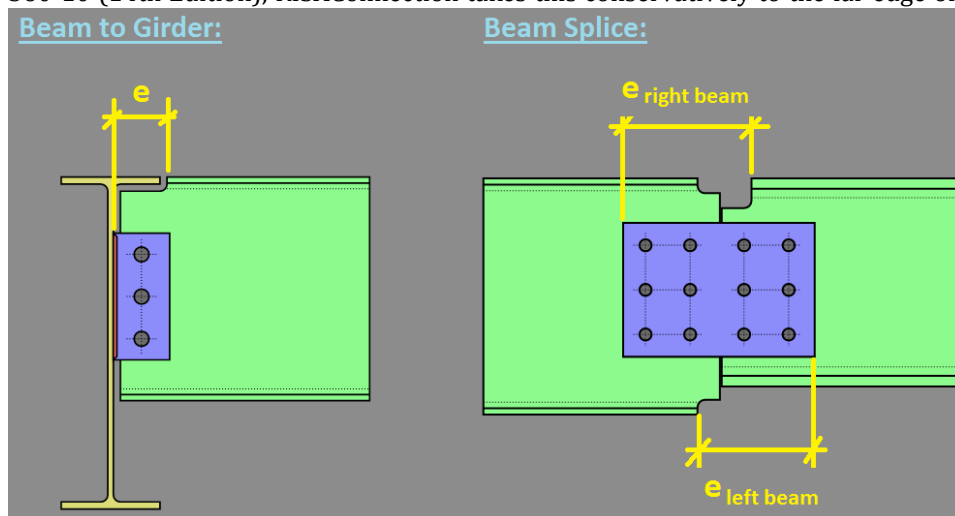

- I_n - The moment of inertia of the coped section.
- Y_c - The location of the neutral axis plate = (distance to the neutral axis of the uncoped beam) - (distance to the neutral axis of the coped beam) - (vertical cope dimension).
- Y_{max} - The maximum distance from the neutral axis to an extreme fiber of the section.

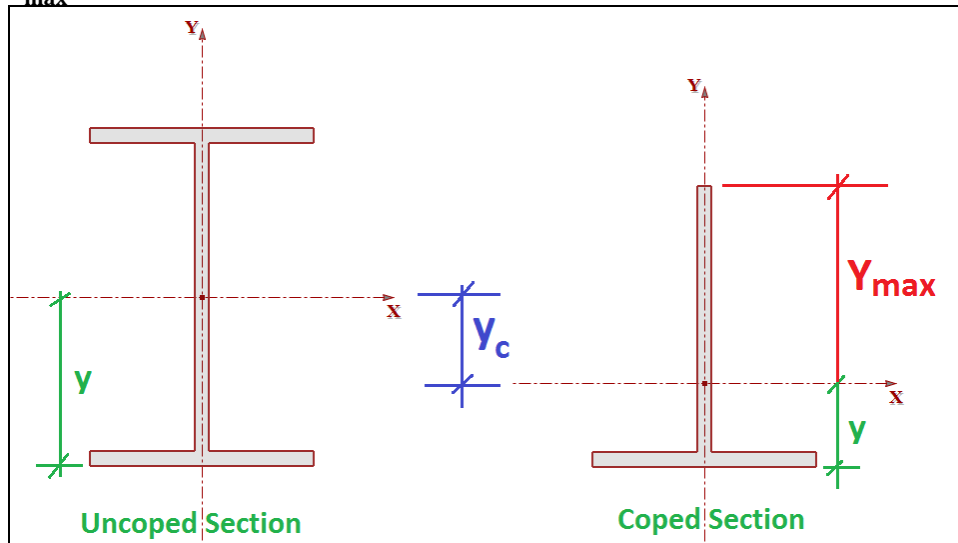

This code check procedure is based on guidelines given in the AISC 14th Edition Manual. Specifically the topic on Connecting Elements Subject to Flexure, which can be found on page 9-6. It is also explicitly outlined in the AISC 13th Edition Manual on page 9-6.

Local Web Buckling Strength

The webs of coped beams have reduced strength to resist local buckling because they are not stiffened by the coped flange. This failure state is determined by multiplying the critical buckling stress by the net section modulus. This buckling is judged to be a more ductile limit state than rupture and has, therefore, been given a phi factor of 0.90 and an Omega factor of 1.67.

Coped Beam Local Web Buckling	60.0000 kips	197.3426 kips	0.30	PASS
$R_n = \min(F_{cr}, F_y) * S_{net}/e$		$\phi = 0.9$	<i>(AISC 14th Eq. 9-7)</i>	
F_{cr}	112.7163 ksi	<i>Available buckling $F_{cr} = \pi^2 * E * (t_w/h_o)^2 * f * k / (12 * (1 - \nu^2))$</i>		
F_y	50.0000 ksi	<i>Minimum yield stress of material</i>		
S_{net}	16.6974 in ³	<i>$S_{net} = I_n / Y_{max}$ elastic section modulus of the cross section</i>		
e	3.8075 in	<i>Distance from the face of the cope to the point of inflection</i>		
E	29000.0000 ksi	<i>Modulus of elasticity of steel</i>		
t_w	0.2950 in	<i>Beam web thickness</i>		
h_o	14.8900 in	<i>Reduced beam depth</i>		
ν	0.3000	<i>Poisson's ratio</i>		
f	0.4160	<i>Plate buckling model adjustment factor</i>		
k	26.3344	<i>Plate buckling coefficient</i>		
ϕR_n	197.3426 kips	<i>Coped beam local web buckling</i>		

The geometric variables include:

- S_{net} - see [Calculation of \$S_{net}\$ \(Net Section Modulus\)](#) above.

- **e** - The distance from the face of the cope to the point of inflection. In accordance with Figure 9-2 in the AISC 360-10 (14th Edition), RISACONNECTION takes this conservatively to the far edge of the shear plate.

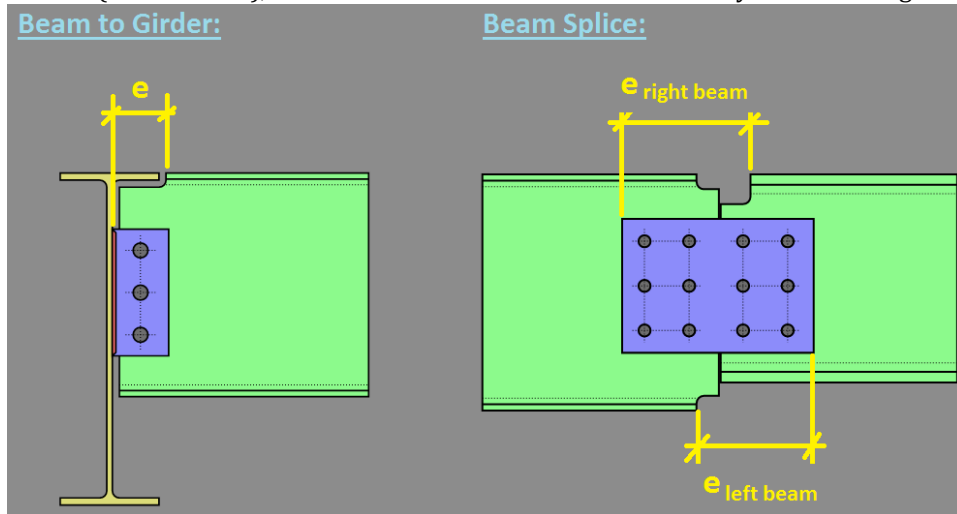

- **f** - Plate Buckling Model Adjustment Factor per AISC 360-10 (14th Edition) page 9-7.
- **k** - Plate Buckling Coefficient per AISC 360-10 (14th Edition) page 9-8.

These code check procedure is based on guidelines given in the AISC 14th Edition Manual. Specifically the topic on Connecting Elements Subject to Flexure (item #1), which can be found on page 9-7.

Flexural Yielding Strength

Flexural yielding of the beam is not considered as it's own code check. However, the critical buckling stress F_{cr} from the Local Buckling Strength calculation is limited to a maximum value of F_y . Therefore, the web buckling strength calculations effectively checks the flexural yielding limit state as well.

Lateral Torsional Buckling Strength

Most of the time the beam will be coped only at the top flange. However, the program calculations will take into account the more unusual case when both flanges are coped. The equations used to calculate the critical buckling stress will be based on the lateral-torsional buckling limit state rather than web local buckling.

Coped Beam Lateral Torsional Buckling	50.0000 kips	104.1848 kips	0.48	PASS
$R_n = \min(F_{cr}, F_y) * S_{net}/e$		$\phi = 0.9$	(AISC 14 th Eq. 9-12)	
F_{cr}	335.6026 ksi	Available buckling $F_{cr} = 0.62 * \pi * E * t_w^2 * f_d / (c * h_o)$		
F_y	50.0000 ksi	Minimum yield stress of material		
S_{net}	8.8152 in ³	$S_{net} = I_n / Y_{max}$ elastic section modulus of the cross section		
e	3.8075 in	Distance from the face of the cope to the point of inflection		
E	29000.0000 ksi	Modulus of elasticity of steel		
t_w	0.2950 in	Beam web thickness		
h_o	13.3900 in	Reduced beam depth		
c	3.3075 in	Cope length		
f_d	3.0236	Adjustment factor		
ϕR_n	104.1848 kips	Coped beam local web buckling		

The geometric variables include:

- S_{net} - see [Calculation of \$S_{net}\$ \(Net Section Modulus\)](#) above.
- e - The distance from the face of the cope to the point of inflection. In accordance with Figure 9-2 in the AISC 360-10 (14th Edition), RISACONNECTION takes this conservatively to the far edge of the shear plate.

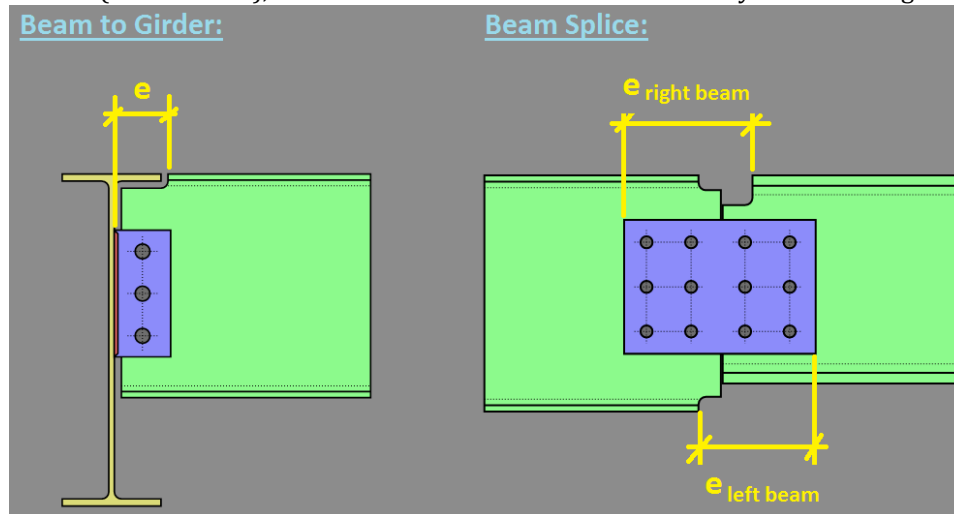

- f_d - Per AISC 360-10 (14th Edition) equation (9-13) on page 9-8.

This code check procedure is based on guidelines given in the AISC 14th Edition Manual. Specifically the topic on Connecting Elements Subject to Flexure (item #2), which can be found on page 9-8.

Flexural Yielding Strength

Flexural yielding of the beam is not considered as it's own code check. However, the critical buckling stress F_{cr} from the Lateral-Torsional Buckling Strength calculation is limited to a maximum value of F_y . Therefore, the web buckling strength calculations effectively checks the flexural yielding limit state as well.

Limitations

- **Effect of Bolt Holes on Net Section Modulus Calculation:** The presence of bolt holes in the web of the beam do not affect the RISACONNECTION calculations of the net section modulus. One could make an argument that they should be included, though AISC's design examples do not reduce S_{net} based on the presence of these bolt holes.
- **Web Local Buckling of Beams Coped at Both Flanges:** RISACONNECTION does not currently calculate the web local buckling limit state for beams coped at both flanges. Instead the lateral-torsional buckling of the web is assumed to control.

Column Connection Checks

This section is specific to column checks for moment connections or shear connections with axial force.

Force Distribution

This section applies to flange forces on moment connections only. Please see [Required Flange Forces](#) to see how RISACONNECTION calculates the flange forces when moment and axial loads are present.

Shear connections are assumed to carry all axial load through the connecting elements.

Moment Arm

The depth of the moment arm between flange forces (d_c) is described below. RISACONNECTION assumes these to be applied at the centroid of the beam flange (for End Plate and Direct Weld Moment Connections) or that of the flange plates (for Flange Plate Moment Connections).

Flange Plate Moment Connection

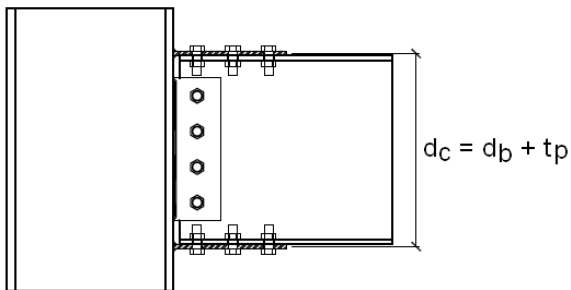

End Plate Moment Connection

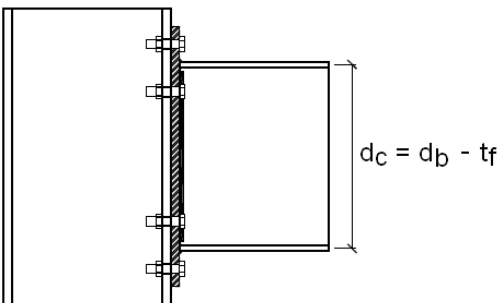

Direct Weld Moment Connection

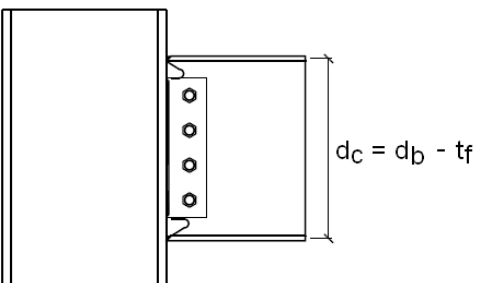

Concentrated Force Location

For many of these checks where these forces are transferred into the column defines which equation you use in the specification. RISACONNECTION defines these locations for each moment connection type as:

- **Flange plate moment connections:** This is taken as the Top Column Dist (from the [Loading](#) input section) minus half of the thickness of the flange plate. This is the location where the centroid of the top flange plate transmits its force into the column.
- **End plate moment connections and Direct Weld moment connections:** This is taken as the Top Column Dist (from the [Loading](#) input section) plus half of the thickness of the beam flange. This is the location where the centroid of the top flange transmits its force into the column.

Note that we always assume the top flange is in compression for these moment connections, or we assume that the moment can be reversed.

k and N Assumptions

The AISC 360-10 specification specifies k as the distance from outer face of the column flange to the web toe of the fillet. Table 1-1 from the 14th Edition Steel Manual list both a k_{det} and a k_{des} value. RISACONNECTION assumes $k = k_{des}$ for this value.

N is defined as the bearing length of the applied force. Therefore this value differs based on the weld type specified to connect the beam flange to the column or end plate. RISACONNECTION uses the following assumptions when calculating this value:

Flange Plate Moment Connection

A. Fillet weld of specified size w

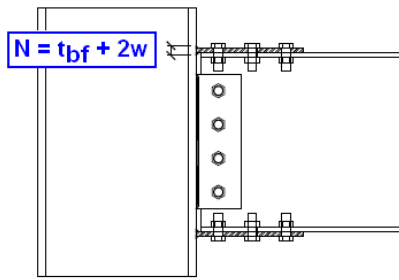

B. CJP weld

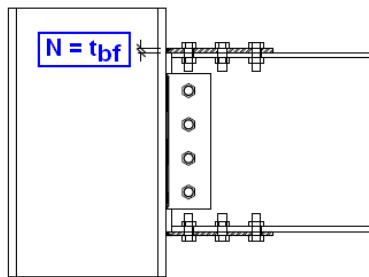

C. PJP weld with an effective throat thickness of w

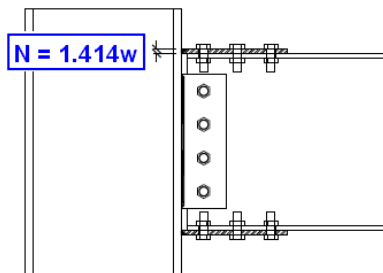

End Plate Moment Connection

A. Fillet weld of specified size w

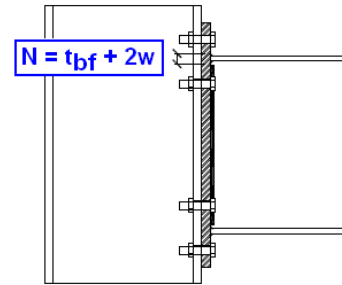

B. CJP weld

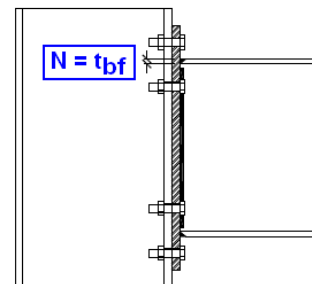

Direct Weld Moment Connection

A. CJP weld

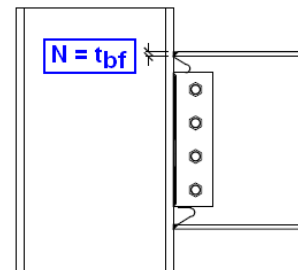

Column Flange Bending (Shear Connections)

This column flange bending capacity check is calculated per section J10.1 of the AISC 360-10 specification. Expand this section of the design report and RISACONNECTION will provide you with the exact equation, code reference, listed variables, as well as the code check value and pass or failure notification.

Column Flange Bending	50.00 kips	141.78 kips	0.35	PASS
$R_n = 6.25 * t_f^2 * F_y$		$\phi = 0.90$ (J10-1)		
d_{end}	20.84 in	<i>Distance from concentrated force to top of column</i>		
t_f	0.71 in	<i>Column flange thickness</i>		
F_y	50.00 ksi	<i>Minimum yield stress of column</i>		
ϕR_n	141.78 kips	<i>Column flange local bending</i>		

Top of Column Distance

Per section J10.1 of the AISC 360-10 specification, the available strength shall be reduced if the force application is at a distance less than $10*t_f$ from the end of the member. This can be addressed in RISACONNECTION by adjusting the user input Top Column Distance in the [Loading](#) section of Connection Properties. Please see the [Concentrated Force Location](#) section for more information on how this location is calculated.

For instance, if Concentrated Force Location < $10*t_f$, RISACONNECTION will reduce R_n by 0.5.

Note:

- This is only checked in Shear Connections if the connection includes a tensile axial load.

Column Flange Bending (Moment Connections)

This moment capacity check applies to the Beam Flange Plate Moment Connection. This check is calculated per section J10.1 of the AISC 360-10 specification. Expand this section of the design report and RISACONNECTION will provide you with the exact equation, code reference, listed variables, as well as the code check value and pass or failure notification. See the [Moment Arm](#) section for more information on how this value is calculated.

Column Flange Bending		44.2396 kips	141.7781 kips	0.31	PASS
$R_n = 6.25 * F_{yf} * t_f^2$			$\phi = 0.90$ (I10-1)		
d_{end}	19.8125 in				Distance from concentrated force to top of column
F_{yf}	50.0000 ksi				Minimum yield stress of column
t_f	0.7100 in				Column flange thickness
ϕR_n	141.7781 kips				Column flange local bending
d_m	16.2750 in				Moment arm between the flange forces
R_{req}	44.2396 kips				Required Flange Force (tension)

Top of Column Distance

Per section J10.1 of the AISC 360-10 specification, the available strength shall be reduced if the force application is at a distance less than $10*t_f$ from the end of the member. This can be addressed in RISACONNECTION by adjusting the user input Top Column Distance in the [Loading](#) section of Connection Properties. Please see the [Concentrated Force Location](#) section for more information on how this location is calculated.

For instance, if Concentrated Force Location < $10*t_f$, RISACONNECTION will reduce R_n by 0.5.

Column Flexural Yielding

This check applies to the End Plate Moment Connection. This check is calculated per Section 3.12.15 and Table 3.4 of the AISC Steel Design Guide 4 (Second Edition). Expand this section of the design report and RISACONNECTION will provide you with the exact equation, code reference, listed variables, as well as the code check value and pass or failure notification.

Column Flexural Yielding		46.5417 kips	261.2984 kips	0.18	PASS
$R_{cf} = F_y * t_{fc}^2 * Y_c / d_m$, where $\phi = 0.90$		(DG-4-2 nd (3.21))			
$Y_c = 0.5 * b_{fc} * [h_1 * (1/s) + h_0 * (1/s)] + 2/g * [h_1 * (s + 0.75 * c) + h_0 * (s + 0.25 * c) + 0.5 * c^2] + 0.5 * g$					
F_y	50.0000 ksi	<i>Minimum yield stress of column</i>			
t_{fc}	0.7100 in	<i>Column flange thickness</i>			
Y_c	178.1959 in	<i>Yield-line mechanism parameter</i>			
b_{fc}	14.5000 in	<i>Column flange width</i>			
h_0	17.1850 in	<i>Distance from the centerline of the beam compression flange to the centerline of tension bolt row N 0</i>			
h_1	13.1850 in	<i>Distance from the centerline of the beam compression flange to the centerline of tension bolt row N 1</i>			
c	4.0000 in	<i>Column bolts vertical gage $c = p_{fo} + p_{fi} + t_{fb}$</i>			
p_{fo}	1.5000 in	<i>Column bolts flange pitch (outer)</i>			
p_{fi}	2.0700 in	<i>Column bolts flange pitch (inner)</i>			
t_{fb}	0.4300 in	<i>Beam flange thickness</i>			
s	3.2977 in	<i>Distance from centerline of tension bolt row to the edge of the yield line $s = 0.5 * (b_{fc} * g)^{0.5}$</i>			
g	3.0000 in	<i>Beam bolts horizontal gage</i>			
d_m	15.4700 in	<i>Moment arm between the flange forces</i>			
ϕR_{cf}	261.2984 kips	<i>Column flange flexural strength</i>			
R_{req}	46.5417 kips	<i>Required Flange Force (tension)</i>			

This check contains some complicated geometry to approximate the yield line pattern. Below are graphical explanations of some of the more complicated terms:

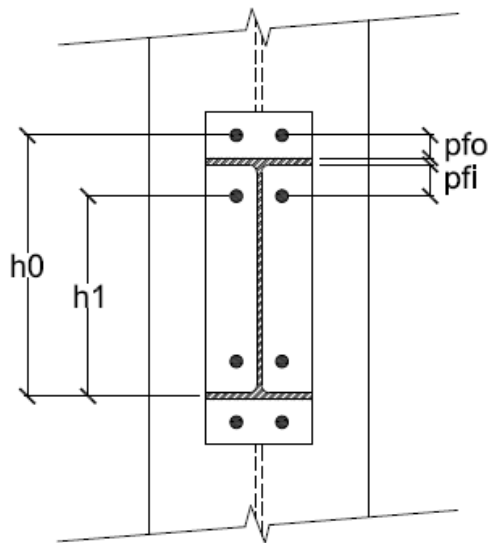

**4 Bolt Layout Beam End Plate:
Outside Face of Column Flange**

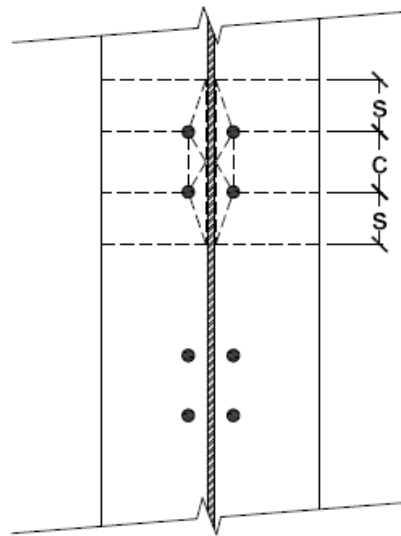

**4 Bolt Layout Beam End Plate:
Inside Face of Column Flange**

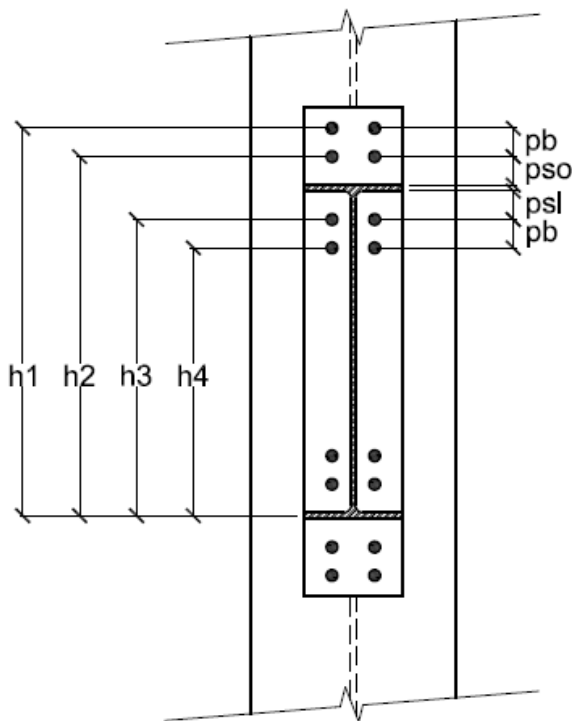

**8 Bolt Layout Beam End Plate:
Outside Face of Column Flange**

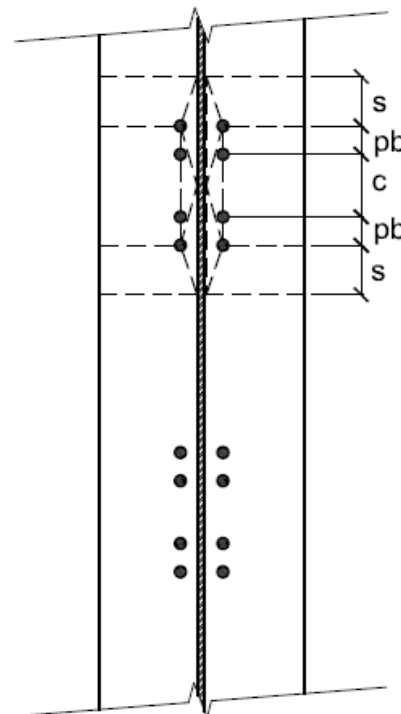

**8 Bolt Layout Beam End Plate:
Inside Face of Column Flange**

Some End Plate connections do not have column yield line formulas specifically listed in the design guides.

Note:

- The column yield lines for the 8 bolt (unstiffened) connection is not given in the design guides. But, can be found in section 4.4.5.5 and Figure 4-15 of Emmett Sumner's PhD thesis, Unified Design of Extended End-Plate Moment Connections Subject to Cyclic Loading.

- The column yield lines for the MRE1/3 connection is not given in the design guides. But, can be found in section 4.4.5.6 and Figure 4-16 of Emmett Sumner's PhD thesis, Unified Design of Extended End-Plate Moment Connections Subject to Cyclic Loading.
- The 2 bolt flush end plate connections will have the same yield lines as the Y_p values in table 3-2 of AISC Design Guide 16. The only difference is that b_p (plate width) is replaced with b_{cf} (column flange width), t_p (plate thickness) with t_{cf} (column flange thickness). In addition "s" is used instead of P_f for the distance to the top yield line unless a transverse column stiffener is present in which case the distance between this stiffener and the top row of bolts is used in place of P_f .
- The 4 bolt flush end plate connections will have the same yield lines as the Y_p values in table 3-3 of AISC Design Guide 16. The same differences mentioned in the bullet point above for the 2 bolt flush connection also apply to the 4 bolt flush connections.

Column Web Punching Shear (Shear Connections)

The column web punching shear capacity check is calculated per the *AISC 15th edition Steel Design Manual* section on **Plate Elements Subjected to Out-of-Plane Loads** on page 9-14. Expand this section of the design report and RISACONNECTION will provide you with the exact equation, code reference, listed variables, as well as the code check value and pass or failure notification. This check is included for beam to column shear connections with any (compression or tension) axial load.

Unfortunately older versions of the AISC Steel Design Manual do not give direction on out of plane checks on a Wide Flange column web, but you may opt to check these per the AISC 15th edition requirements by selecting the **Include AISC 15th Out of Plane Web Checks** check-box on the [Solution tab of the \(Global\) Model Settings](#).

Column Web Punching Shear	15.0000 kips	1068.0000 kips	0.01	PASS
$R_n = 0.6 * F_{yc} * t_{wc} * (2 * c_{eff} + 2 * L)$		$\Omega = 1.50$	(AISC 15 th Eq. 9-29)	
F_{yc}	50.0000 ksi	Minimum yield stress of column material		
F_{ya}	36.0000 ksi	Minimum yield stress of clip angle material		
t_{wc}	0.7500 in	Column web thickness		
t_c	0.3750 in	Clip angle thickness		
d_c	28.1000 in	Column depth		
k_{det}	2.2500 in	Distance from outer column flange to web toe fillet		
B_c	23.6000 in	Width of unbraced column web, $B_c = d_c - 2 * k_{det}$		
B_a	8.2950 in	Width of clip angle connection at column web		
c_{eff}	23.6000 in	Effective width of clip angle per Eq. K1-1, $c_{eff} = B_e$		
L	12.0000 in	Length of clip angle		
R_n/Ω	1068.0000 kips	Column web punching shear strength		

Note:

- Per the direction on *AISC 15th edition Steel Design Manual* page 9-15, RISACONNECTION assumes that the column flanges are not restrained and therefore always takes the effective width, c_{eff} = to the T dimension of the column. This is always the case, regardless of if the connection is bolted or welded because the code does not give specific direction for bolted connections.
- If the column is a HSS Pipe or Tube section, this check is done per AISC Steel Design Manual equation (10-7) for shear tabs, or equation (9-29) for clip angles when the AISC 15th edition design code is selected. Please see the [HSS Checks](#) topic for more information.

Column Web Axial Yielding (Shear Connections to Column Web)

The column web axial yield capacity check is calculated per the *AISC 15th edition Steel Design Manual* equation (9-31) on page 9-16. Expand this section of the design report and RISACONNECTION will provide you with the exact equa-

tion, code reference, listed variables, as well as the code check value and pass or failure notification. This check is included for beam to column shear connections with any (compression or tension) axial load.

Unfortunately older versions of the AISC Steel Design Manual do not give direction on out of plane checks on a Wide Flange column web, but you may opt to check these per the AISC 15th edition requirements by selecting the **Include AISC 15th Out of Plane Web Checks** check-box on the [Solution tab of the \(Global\) Model Settings](#).

Column Web Axial Yielding		15.0000 kips	120.8334 kips	0.12	PASS
$R_n = (0.25 * t^2 * F_y) * ((4 * (2 * T * a * b * (a + b))^{0.5} + L * (a + b)) / (a * b))$			$\phi = 1.00$	(AISC 15 th Eq.9-31)	
F_y	50.0000 ksi	Minimum yield stress of column material			
t	0.7500 in	Column web thickness			
d_c	28.1000 in	Column depth			
k_{det}	2.2500 in	Distance from outer face of column flange to web toe of fillet			
T	23.6000 in	Width of unbraced column web, $T = d_c - 2 * k_{det}$			
c	8.2950 in	Width of clip angle connection at column web			
a	7.6525 in	Distance along web from one edge of clip angle to nearest support (left side)			
b	7.6525 in	Distance along web from one edge of clip angle to nearest support (right side)			
L	12.0000 in	Length of clip angle			
ϕR_n	120.8334 kips	Column web axial yielding strength			

Column Web Flexural Yielding (Shear Connections to Column Web)

The column web flexural yield capacity check is calculated per the AISC 15th edition Steel Design Manual equation (9-35) on page 9-17. Expand this section of the design report and RISACONNECTION will provide you with the exact equation, code reference, listed variables, as well as the code check value and pass or failure notification. This check is included for any shear connection with moment at the column due to eccentricity in the shear connection.

Unfortunately older versions of the AISC Steel Design Manual do not give direction on out of plane checks on a Wide Flange column web, but you may opt to check these per the AISC 15th edition requirements by selecting the **Include AISC 15th Out of Plane Web Checks** check-box on the [Solution tab of the \(Global\) Model Settings](#).

Column Web Flexural Yielding		246.7500 kips-in	991.8713 kips-in	0.25	PASS
$M_n = (0.25 * t^2 * F_y) * ((4 * (2 * a * b * c * T * \rho)^{0.5} + L * \rho) / (2 * a * b * c)) * Q_f$			$\phi = 1.00$	(AISC 15 th Eq.9-35)	
P	15.0000 kips	Required axial load (positive = compression)			
V	80.0000 kips	Required shear load			
e_x	3.0000 in	Horizontal eccentricity			
e_y	0.4500 in	Vertical eccentricity			
M_e	246.7500 kips-in	Required moment due to eccentricity, $M_e = P * e_y + V * e_x$			
F_y	50.0000 ksi	Minimum yield stress of column material			
t	0.7500 in	Column web thickness			
d_c	28.1000 in	Column depth			
k_{det}	2.2500 in	Distance from outer face of column flange to web toe of fillet			
T	23.6000 in	Width of unbraced column web, $T = d_c - 2 * k_{det}$			
c	8.2950 in	Width of clip angle connection at column web			
a	7.6525 in	Distance along web from one edge of clip angle to nearest support (left side)			
b	7.6525 in	Distance along web from one edge of clip angle to nearest support (right side)			
ρ	244.0765 in ²	Out of plane bending factor per Eq.9-36, $\rho = 2 * a * b + a * c + b * c$			
Q_f	1.0000	Chord stress interaction parameter (user input)			
L	12.0000 in	Length of clip angle			
ϕM_n	991.8713 kips-in	Column web flexural yielding strength			

Note:

- This check includes a column stress interaction parameter, Q_f . There are some cases where RISACONNECTION cannot determine this value, so it relies on the user adjusting this in the **Loading** input properties:

Loading (LRFD)	
Shear Load, kips.	80.0000
Axial Load, kips.	15.0000
Q_f	1.0000
Eccentric Moment Calculation	Include All Eccentricities

Column Web Yielding (Shear Connections to Column Flange)

This column web yielding capacity check is calculated per section J10.2 of the AISC 360-10 specification for Wide Flange Columns with beams connected to the column flange. Expand this section of the design report and RISACONNECTION will provide you with the exact equation, code reference, listed variables, as well as the code check value and pass or failure notification.

Column Web Yielding		50.0000 kips	408.1000 kips	0.12	PASS
$R_n = (5 * k + N) * F_y * t_w$			$\phi = 1.00$	(J10-2)	
d_{end}	21.5000 in	Distance from concentrated force to top of column			
d_{col}	14.0000 in	Column depth			
k	1.3100 in	Distance from outer face of the flange to the web toe of the fillet			
N	12.0000 in	Length of bearing			
F_y	50.0000 ksi	Minimum yield stress of column			
t_w	0.4400 in	Column web thickness			
ϕR_n	408.1000 kips	Column web local yielding			

Top of Column Distance

Per section J10.2 of the AISC 360-10 specification, there are two equations that apply to this check: J10-2 and J10-3. RISACONNECTION calculates the **Concentrated Force Location** to see which of these equations applies. Please see the [Concentrated Force Location](#) section for more information on how this location is calculated.

Therefore, if the Concentrated Force Location $> d_{beam}$, RISACONNECTION will use equation J10-2. If the Concentrated Force Location $\leq d_{beam}$, RISACONNECTION will use equation J10-3.

Note:

- This is only checked in Shear Connections if the connection includes an axial load.
- Column Web failure due to punching shear and / or web plastification (yield lines for moment applied to shear tab) are NOT currently considered.

Column Web Yielding (Moment Connections to Column Flange)

This check applies to *Beam Flange Moment Connections* and *End Plate Moment Connections* for Wide Flange Columns with beams connected to the column flange but is calculated slightly differently for each type of check.

Flange Plate Moment Connection

For Flange Plate Moment Connections, this check is calculated per section J10.2 of the AISC 360-10 specification. Expand this section of the design report and RISACONNECTION will provide you with the exact equation, code

reference, listed variables, as well as the code check value and pass or failure notification. See the [Moment Arm](#) section for more information on how this value is calculated.

End Plate Moment Connection

For End Plate Moment Connections, section J10.2 of the AISC 360-10 specification is not as clear. Therefore, RISACONNECTION instead references the AISC Design Guide 4, 2nd Edition which references the AISC 2nd Edition LRFD code.

This code has a much clearer reference to End Plate Moment connections and assumes a larger projection, as shown in the image below.

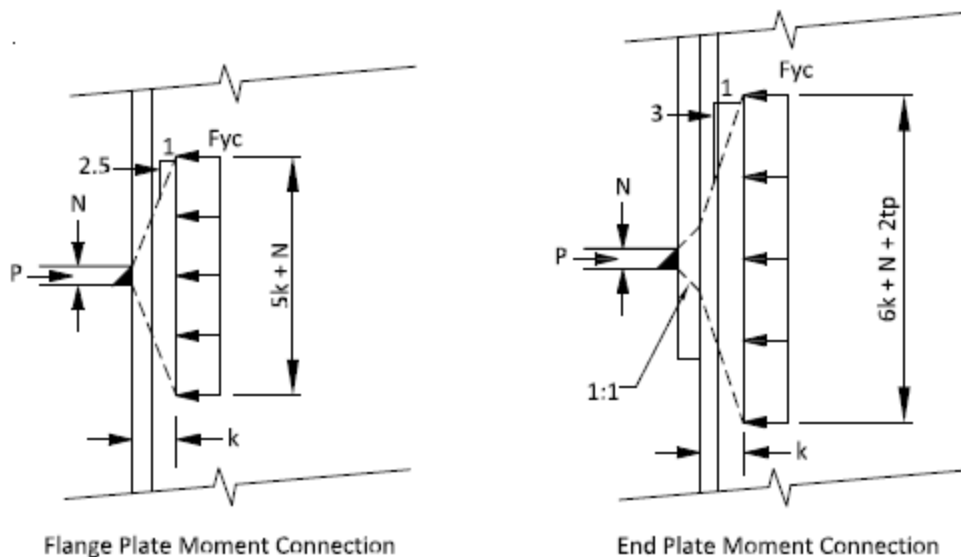

Expand this section of the design report and RISACONNECTION will provide you with the exact equation, code reference, listed variables, as well as the code check value and pass or failure notification. See the [Moment Arm](#) section for more information on how this value is calculated.

Note:

- For flush end plate connections, the spread of the axial force is not addressed in any of the design guides. Therefore, a value between the two formulas is used ($5.5k + N + 1.0 \cdot t_p$). This is rational because it assumes a spread of load on one side is the same as the end plate connection, but on the other side it is assumed to be the same as the direct weld connection.
- In the case of flush end plates with double fillet welds, the plates are extended the distance of the weld leg + an extra 1/16th of an inch for any weld legs greater than 0.25".

Top of Column Distance

Per section J10.2 of the AISC 360-10 specification, there are two equations that apply to this check: J10-2 and J10-3. RISACONNECTION calculates the **Concentrated Force Location** to see which of these equations applies. Please see the [Concentrated Force Location](#) section for more information on how this location is calculated.

Therefore, if the Concentrated Force Location $> d_{beam}$, RISACONNECTION will use equation J10-2. If the Concentrated Force Location $\leq d_{beam}$, RISACONNECTION will use equation J10-3.

Column Web Crippling (Shear Connections)

This column web crippling capacity check is calculated per section J10.3 of the AISC 360-10 specification. Expand this section of the design report and RISACONNECTION will provide you with the exact equation, code reference, listed

variables, as well as the code check value and pass or failure notification.

Column Web Crippling	50.00 kips	344.86 kips	0.14	PASS
$R_n = 0.8 t_w^2 (1 + 3(N/d_{col}) + (t_w/t_f)^{1.5}) + (E F_y t_f/t_w)^{0.5}$		$\phi = 0.75$ (J10-4)		
d_{end}	20.84 in	Distance from concentrated force to top of column		
N/d_{col}	0.64	Bearing length to column depth ratio		
d_{col}	14.00 in	Column depth		
t_w	0.44 in	Column web thickness		
t_f	0.71 in	Column flange thickness		
N	9.00 in	Length of bearing		
F_y	50.00 ksi	Minimum yield stress of column		
E	29000.00 ksi	Modulus of elasticity of column		
ϕR_n	344.86 kips	Column web crippling capacity		

There are three equations that come into play for this check. When the *concentrated compressive force* to be resisted is applied at a distance from the member end that is greater than or equal to $d_{col}/2$ use equation J10-4. If this distance is less than $d_{col}/2$, then use either J10-5a or J10-5b. Please see the [Concentrated Force Location](#) section for more information on how this location is calculated.

The differentiation between equations J10-5a and J10-5b depends on the ratio of bearing length to overall depth of the beam (N/d). See the Column Moment Checks topic for information on [calculating N](#). If $N/d \leq 0.2$, then equation J10-5a is used. If $N/d > 0.2$, then equation J10-5b is used.

The program will perform all of these dimensional checks and use the appropriate equation automatically.

Note:

- This is only checked in Shear Connections if the connection includes a compressive axial load.
- When the AISC 15th (360-16) code is selected, this check includes a Q_f factor. For all wide flange and HSS columns in tension, this is taken as $Q_f = 1$. For all other cases, see AISC 15th Table K3.2.

Column Web Crippling (Moment Connections)

Web crippling is local buckling that occurs when the web is slender (i.e. h/t_w is large). The behavior is more restrained when the point load is applied away from the ends of the member. Because of this there are separate equations for when a concentrated transverse load is located near or away from the end of the member. This limit state is to be checked at each location where a concentrated force is applied transverse to the axis of a member.

The AISC 360-10 Specification section J10.3 gives the capacity equations to consider column web crippling.

Column Web Crippling	102.620 kips	195.142 kips	0.53	PASS
$R_n = 0.8 * t_w^2 * (1 + 3 * (N/d_{col}) * (t_w/t_f)^{1.5}) * (E * F_y * t_f/t_w)^{0.5}$		$\phi = 0.75$	(J10-4)	
d_{end}	20.220 in	<i>Distance from concentrated force to top of column</i>		
N/d_{col}	0.067	<i>Bearing length to column depth ratio</i>		
d_{col}	14.000 in	<i>Column depth</i>		
t_w	0.440 in	<i>Column web thickness</i>		
t_f	0.710 in	<i>Column flange thickness</i>		
N	0.940 in	<i>Length of bearing</i>		
F_y	50.000 ksi	<i>Minimum yield stress of column</i>		
E	29000.000 ksi	<i>Modulus of elasticity of column</i>		
ϕR_n	195.142 kips	<i>Column web crippling capacity</i>		
d_m	15.460 in	<i>Moment arm between the flange forces</i>		
R_{req}	102.620 kips	<i>Required Flange Force (compression)</i>		

There are three equations that come into play for this check. When the *concentrated compressive force* to be resisted is applied at a distance from the member end that is greater than or equal to $d_{col}/2$ use equation J10-4. If this distance is less than $d_{col}/2$, then use either J10-5a or J10-5b. This [location where this compressive force occurs](#) is defined earlier in this topic.

The differentiation between equations J10-5a and J10-5b depends on the ratio of bearing length to overall depth of the beam (N/d). See information earlier in this topic for information on [calculating N](#). If $N/d \leq 0.2$, then equation J10-5a is used. If $N/d > 0.2$, then equation J10-5b is used.

The program will perform all of these dimensional checks and use the appropriate equation automatically.

Note:

- When the AISC 15th (360-16) code is selected, this check includes a Qf factor. For all wide flange and HSS columns in tension, this is taken as Qf = 1. For all other cases, see AISC 15th Table K3.2.

Column Web Buckling (Moment Connections)

This check applies to both Beam Flange Moment Connections and End Plate Moment Connections. This check is calculated per section J10.5 of the AISC 360-10 specification. Expand this section of the design report and RISAConnection will provide you with the exact equation, code reference, listed variables, as well as the code check value and pass or failure notification. See the [Moment Arm](#) section for more information on how this value is calculated.

Column Web Buckling	102.620 kips	194.694 kips	0.53	PASS
$R_n = 24 * t_w^3 * (E * F_y)^{0.5} / h$		$\phi = 0.90$	(J10-8)	
d_{end}	20.220 in	<i>Distance from concentrated force to top of column</i>		
d_{col}	14.000 in	<i>Column depth</i>		
t_w	0.440 in	<i>Column web thickness</i>		
F_y	50.000 ksi	<i>Minimum yield stress of column</i>		
E	29000.000 ksi	<i>Modulus of elasticity of column</i>		
h	11.380 in	<i>Clear distance between flanges $h = d - 2 * k_{des}$</i>		
ϕR_n	194.694 kips	<i>Column web compression buckling</i>		
d_m	15.460 in	<i>Moment arm between the flange forces</i>		
R_{req}	102.620 kips	<i>Required Flange Force (compression)</i>		

Note:

- Technically, this check is only valid when the column web is restrained at both flanges (i.e., when there is a moment connection on both sides of the column). In the standalone version of RISACONNECTION, this check is no longer performed, as it is not required unless there is a moment on each side of the column. However, when the model is integrated from RISA-3D or RISAFloor, this check is conservatively performed to account for potential moment connections on both sides.
- When the AISC 15th (360-16) code is selected, this check includes a Q_f factor. For all wide flange and HSS columns in tension, this is taken as $Q_f = 1$. For all other cases, see AISC 15th Table K3.2.

Top of Column Distance

Per section J10.5 of the AISC 360-10 specification, the available strength shall be reduced by 50% if the force application is at a distance less than half the depth of the column. RISACONNECTION refers to this value as the **Concentrated Force Location** and is calculated per the user input **Top Column Distance**. Please see the [Concentrated Force Location](#) section for more information on how this location is calculated.

For instance, if Concentrated Force Location $< 0.5 \cdot d_{\text{beam}}$, RISACONNECTION will reduce R_n by 0.5.

Column Panel Zone Shear

Column web panel zone shear is a phenomenon that occurs when double-concentrated forces are applied to a member. A moment connection's beam flange forces creates these double concentrated forces.

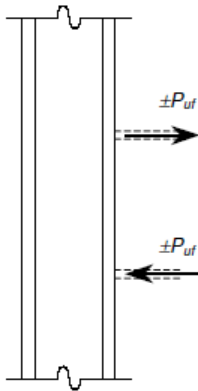

These forces cause a shear to the web panel zone that we are checking here.

Column Panel Zone Shear		29.66 kips	297.89 kips	0.10	PASS
$R_n = 0.60 * F_{yc} * d_c * t_{wc}$ ($\alpha * P_r \leq 0.4 * P_c$), $\alpha = 1.0$			$\phi = 0.90$ (J10-9)		
P_r	18.48 kips		<i>Axial force in the column at the connection</i>		
P_c	1555.00 kips		$P_c = P_y = F_{yc} * A$		
F_{yc}	50.00 ksi		<i>Minimum yield stress of column</i>		
A	31.10 in ²		<i>Column cross-sectional area</i>		
d_c	18.70 in		<i>Column depth</i>		
t_{wc}	0.59 in		<i>Column web thickness</i>		
t_{fc}	0.94 in		<i>Column flange thickness</i>		
b_{fc}	11.20 in		<i>Column flange width</i>		
d_b	26.70 in		<i>Beam depth</i>		
ϕR_n	297.89 kips		<i>Web panel zone capacity</i>		
R_f	29.40 kips		<i>Beam flange force. $R_f = M / d_m$</i>		
M	63.85 kips-ft		<i>Moment demand</i>		
d_m	26.06 in		<i>Moment arm from centerline forces</i>		
V_{above}	0.26 kips		<i>Story shear in column above connection</i>		
R_p	29.66 kips		<i>Panel zone shear demand. $R_p = R_f + V_{above}$</i>		

There are four equations from the AISC 360-10 specification that are used, equations J10-9, J10-10, J10-11 and J10-12. The program assumes that the effect of panel-zone deformation on frame stability is not considered in the analysis, thus equations J10-11 and J10-12 are never used. Whether to use J10-9 or J10-10 depends on the axial force in the column at the location of the connection. This force is input in the [Loading](#) section. If this force is $\leq 0.4 * P_c$ then J10-9 is used. If $P_r > 0.4 * P_c$, then J10-10 is used.

Note:

- When the AISC 15th (360-16) code is selected, this check includes an additional factor, α . For LRFD design, this shall be taken as 1.0. For ASD design, this shall be taken as 1.6.

Story Shear

The actual demand panel zone shear that occurs can be reduced by the story shear coming into the panel zone.

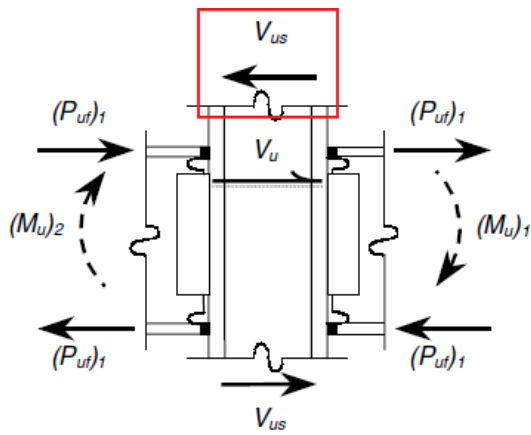

This story shear is also an input in the [Loading](#) section. If there is story shear, then the program calculates an M_{equiv} as the design demand. This is a reduced demand based on a reduced panel zone shear due to this story shear. Because the code checks are based on converting the capacities into equivalent moment capacities, the same must be done for the moment demand in this case.

RISACONNECTION will take all of the inputs, perform the applicable checks and use the appropriate equation.

Column Web Out of Plane Checks

The AISC 15th (360-16) edition Steel Construction Manual introduced explicit out of plane checks for column web connections loaded out of plane. These checks are listed below. Older versions of the Steel Construction Manuals did not include direction for these checks, but RISACONNECTION will allow you to include the checks along with older codes if you select the "Include AISC 15th Out of Plane Web Checks" check box on the [Solution tab of Project Settings](#).

Top Column Distance — HSS Tube and Pipe Columns (AISC 360-22)

The Top Column Distance input parameter is available in the Connection Properties grid for connections to Wide Flange columns in all supported AISC editions. Beginning with AISC 360-22 (16th Edition), this parameter is also active for connections where the column is an HSS Rectangular Tube (for all applicable shear and brace connections) and for Column/Beam Shear Tab Shear and Vertical Brace Diagonal connections where the column is an HSS Pipe.

For AISC 15th Edition and earlier, the Top Column Distance parameter is still shown in the properties grid for Tube columns for informational purposes, but it does not affect calculations; the end-distance reduction is only applied when the AISC 16th Edition code is selected.

When Top Column Distance is less than the code-specified minimum end distance limit, the available strength for the affected out-of-plane web checks is reduced as described in the HSS End Distance Reduction section below.

Column Web Punching Shear

The punching shear limit for a clip angle or end plate connection to a column web is checked per eqn (9-29) on page 9-14 of the 15th Edition Steel Construction Manual. For more detail see [Column Web Punching Shear \(Shear Connections\)](#).

Column Web Punching Shear	15.00 kips	387.20 kips	0.04	PASS
$R_n = 0.6 * F_y * t * (2 * c_{eff} + 2 * L)$		$\Omega = 1.50$	<i>(AISC 15th Eq.9-29)</i>	
F_y	50.00 ksi	<i>Minimum yield stress of column material</i>		
t_{wc}	0.44 in	<i>Column web thickness</i>		
d_c	14.00 in	<i>Column depth</i>		
k_{det}	2.00 in	<i>Distance from outer column flange to web toe fillet</i>		
T	10.00 in	<i>Width of unbraced column web, $T = d_c - 2 * k_{det}$</i>		
c_{eff}	10.00 in	<i>Effective width of clip angle per Eq.K1-1, $c_{eff} = T$</i>		
L	12.00 in	<i>Length of clip angle</i>		
R_n/Ω	387.20 kips	<i>Column web punching shear strength</i>		

Column Web Axial Yielding

Out of plane transverse loads on a column web are checked per eqn (9-31) on page 9-16 of the 15th Edition Steel Construction Manual. For more detail see [Column Web Axial Yielding \(Shear Connections to Column Web\)](#).

Column Web Axial Yielding	15.00 kips	89.62 kips	0.17	PASS
$R_n = (0.25 * t^2 * F_y) * ((4 * (2 * T * a * b * (a + b))^{0.5} + L * (a + b)) / (a * b))$		$\Omega = 1.50$	<i>(AISC 15th Eq.9-31)</i>	
F_y	50.00 ksi	<i>Minimum yield stress of column material</i>		
t	0.44 in	<i>Column web thickness</i>		
d_c	14.00 in	<i>Column depth</i>		
k_{det}	2.00 in	<i>Distance from outer face of column flange to web toe of fillet</i>		
T	10.00 in	<i>Width of unbraced column web, $T = d_c - 2 * k_{det}$</i>		
c	8.29 in	<i>Width of clip angle connection at column web</i>		
a	0.85 in	<i>Distance along web from one edge of clip angle to nearest support (left side)</i>		
b	0.85 in	<i>Distance along web from one edge of clip angle to nearest support (right side)</i>		
L	12.00 in	<i>Length of clip angle</i>		
R_n/Ω	89.62 kips	<i>Column web axial yielding strength</i>		

Column Web Flexural Yielding

Out of plane moment loads on a column web are checked per eqn (9-35) on page 9-17 of the 15th Edition Steel Construction Manual. For more detail see [Column Web Flexural Yielding \(Shear Connections to Column Web\)](#).

Column Web Flexural Yielding		240.00 kips-in	400.27 kips-in	0.60	PASS
$M_n = (0.25*t^2*F_y)*((4*(2*a*b*c*T*\rho)^{0.5} + L*\rho)/(2*a*b))*Q_f$			$\Omega = 1.50$	(AISC 15 th Eq.9-35)	
P	0.00 kips		Required axial load		
V	80.00 kips		Required shear load		
e_x	3.00 in		Horizontal eccentricity		
e_y	0.45 in		Vertical eccentricity		
M_e	240.00 kips-in		Required moment due to eccentricity, $M_e = V*e_x + P*e_y$		
F_y	50.00 ksi		Minimum yield stress of column material		
t	0.44 in		Column web thickness		
d_c	14.00 in		Column depth		
k_{det}	2.00 in		Distance from outer face of column flange to web toe of fillet		
T	10.00 in		Width of unbraced column web, $T = d_c - 2*k_{det}$		
c	8.29 in		Width of clip angle connection at column web		
a	0.85 in		Distance along web from one edge of clip angle to nearest support (left side)		
b	0.85 in		Distance along web from one edge of clip angle to nearest support (right side)		
ρ	15.60 in ²		Out of plane bending factor (AISC 15 th Eq.9-36), $\rho = 2*a*b + a*c + b*c$		
Q_f	1.00		Column stress interaction parameter (user input)		
L	12.00 in		Length of clip angle		
M_n/Ω	400.27 kips-in		Column web flexural yielding strength		

Out of Plane Check Limitations

- Out of plane checks are not included for supporting girder members because the yield line pattern would not be the same as what is published in the AISC 15th Ed Steel Construction Manual for Column webs.
- Out of plane checks are not included when stabilizer plates are present.
- When the axial load is tension, the yield line dimension c is assumed equal to zero when there is only one row of bolts.
 - When there are more than one rows of bolts, the dimension c is assumed equal to the outermost bolt centerline to centerline spacing ($c = \text{row spacing}$ for 2 rows, $c = 2*\text{row spacing}$ for 3 rows).
- When the axial load is in compression, the yield line dimension c is assumed equal to the width of the clip angle or end plate.
- RISACONNECTION assumes that the column flanges are not restrained and therefore $c_{eff} = T$ per the direction on AISC 15th edition page 9-15. This assumption applies to both welded and bolted connections.
- Threshold limitation: If the axial load is less than 5% of the shear load, RISACONNECTION will take it equal to zero.

HSS Out of Plane Checks

Please see the section on [HSS Checks](#) for the details on similar out of plane checks for HSS connections.

Design Checks for HSS Members

These checks are unique to HSS (Tube and Pipe) members. For bolt and material checks that are not specific to HSS, see the [Bolt & Material Checks](#) topic. For weld information, including weld checks specific to HSS, see the [Weld Checks](#) topic.

HSS Limitations

The tables in chapter K of AISC 360 each have a section on "Limits of Applicability". These mean that if a connection falls outside these limits then the procedures given by AISC and Chapter K may not be sufficient to guarantee a safe connection. It does not necessarily mean that the given code checks are invalid. It may mean that the parameters of the connection fall outside the limits of existing test data or that other limit states not listed could control. These parameters are checked as part of the HSS Limitations limit state, which includes checks for:

- Wall Slenderness
- Material
- Ductility
- Connection Width Ratios
- Aspect Ratios

If any one check fails as part of the HSS Limitations then the entire limit state is considered to fail. When multiple slenderness limitations apply, the most stringent slenderness limitation is used.

HSS Limitations		PASS
Check Column Slenderness	Pass	(K2.3)
B	10.00 in	Column width
H	14.00 in	Column Depth
t	0.47 in	Column Wall Thickness
B/t	21.51	Column Slenderness Ratio
H/t	30.11	Column Slenderness Ratio
B / t_{\max}	35.00	Slender Wall Limit (Table K2.2A)
Check Connection Width Ratio	Pass	(K2.3)
B_b	7.29 in	Branch Width
H_b	9.00 in	Branch Depth
B	10.00 in	Column width
β	0.73	Width Ratio (B_b / B)
η	0.90	Load Length Parameter (H_b / B)
β_{\min}	0.25	Width Ratio Limit (Table K2.2A)
η_{\min}	0.25	Width Ratio Limit (Table K2.2A)
Check Branch Aspect Ratio	Pass	(K2.3)
B_b / H_b	0.81	Branch Aspect Ratio
$B_b / H_{b-\min}$	0.50	Min Ratio Limit (Table K2.2A)
$B_b / H_{b-\max}$	2.00	Max Ratio Limit (Table K2.2A)
Check Column Aspect Ratio	Pass	(K2.3)
B/H	0.71 in	Column Aspect Ratio
B / H_{\min}	0.50 in	Min Aspect Ratio
B / H_{\max}	2.00 in	Max Aspect Ratio
Check Column Material	Pass	(K2.3)
F_y	46.00 in	Column Yield Strength
$F_{y-\max}$	52.00 in	Column Yield Strength Limit (Table K1.2A)

Note:

- The *AISC 360-16 (15th edition)* removed many of the tables in Chapter K so this check may not be included if you have selected the 15th edition design code.

When axial load is present in an **HSS Beam to Column Moment Connection**, the HSS Limitations check includes additional sub-checks from AISC Table K3.2A:

- Width Ratio: $\beta = B_b/B \geq \beta_{\min}$ per Table K3.2A, Row 5
- End Distance: $d_{\text{end}} \geq B\sqrt{(1 - \beta)}$ for T- and Y-connections

Where d_{end} = Top Column Distance (user input)

These additional limits ensure the connection geometry remains within tested parameter ranges for truss-type connections under combined loading.

End Distance Reduction for HSS and Pipe Columns (AISC 360-22)

When AISC 360-22 (16th Edition) is selected, RISACONNECTION checks whether the distance from the connection to the nearer end of the HSS or pipe column (the end distance, d_{end}) is less than a code-specified minimum. When this condition is met, the available strength for the affected checks is reduced. This provision is consistent with the end-distance reduction logic present elsewhere in the AISC Specification (e.g., Sections J10.1 and J10.3), but its explicit application to the Part 9 out-of-plane and Chapter K HSS checks is specific to the 16th Edition Manual.

For HSS Rectangular Tube columns, per AISC 360-22 Section K1.4:

- The minimum end distance is calculated as: $d_{\text{end,lim}} = B(1-B)^{1/2}$, per Eq. K1-7
- When $d_{\text{end}} < d_{\text{end,lim}}$, a strength reduction factor $k_r = 0.5$ is applied to the nominal strength R_n of the following checks:
 - HSS Sidewall Yielding
 - HSS Sidewall Crippling
 - HSS Transverse Plastification (Eq. 9-44)
 - HSS Flexural Plastification (Eq. 9-46)
- The parameters β , B , B_p , d_{end} , and $d_{\text{end,lim}}$ are reported in the detailed check output.. The factor k_r is reported only when $d_{\text{end}} < d_{\text{end,lim}}$.
- This reduction is only applied when the width ratio $\beta > 0.85$. No reduction is made when $\beta \leq 0.85$.

For HSS Pipe columns, per AISC 360-22 Eq. K1-8:

- The minimum end distance is calculated as: $d_{\text{end,lim}} = D(1.25 - B)^{(1/2)}/2$
- When $d_{\text{end}} < d_{\text{end,lim}}$, a factor of 0.5 is applied to the R_n or M_n calculation for:
 - HSS Transverse Plastification (pipe)
 - HSS Flexural Plastification (pipe)
- The parameters β , d_{end} , and $d_{\text{end,lim}}$ are reported in the detailed check output.

Note: No end distance reduction is applied when using AISC 15th Edition (360-16) or earlier, even when the Top Column Distance value is defined.

CSA HSS Limitations

Design of HSS connections per the Canadian *CSA S16* design code refers to the *CIDECT Design Guide 3 for Rectangular Hollow Sections* and *CIDECT Design Guide 1 for Circular Hollow Sections*. The CIDECT checks per Table 4.1 and 7.1 are very similar to those in AISC Chapter K and also are limited to parameters outlined in the "Range of Validity" from [CIDECT Table 4.1 and 7.1](#) which includes checks for:

- Wall Slenderness
- Yield

- Ductility
- Material
- Class
- Connection Width Ratios
- Aspect Ratios

HSS Member Class

When the HSS member is in compression, HSS Class 1 or 2 is required. The HSS class is defined by CSA S16 Table 2. The HSS member is determined to be in compression when the column axial force is positive for the following connections: Shear Tab, Clip Angle (One Side), and Vertical Diagonal Brace. The chord force is assumed to be in compression for the following connections: Chevron Brace, Knee Brace, and HSS to HSS.

HSS Punching Shear

The Punching Shear checks depend on which version of the code you have selected. See the details below.

AISC 15th (360-16) Edition Considerations

Shear Tab

The punching shear limit for a single plate connection to a HSS tube wall is checked per eqn (10-7) on page 10-153 of the 15th Edition Steel Construction Manual. This is applicable to HSS Tube and Pipe columns with a shear tab connection.

HSS Punching Shear	120.00 kips-in	437.23 kips-in	0.27	PASS
$M_n = 0.2 * F_u * t * l_p^2$		$\phi = 0.75$	(AISC 15 th Eq.10-7)	
F_u	58.00 ksi	Column tensile strength		
t	0.35 in	Column wall thickness		
l_p	12.00 in	Plate length		
P	0.00 kips	Required axial load		
V	60.00 kips	Required shear load		
e_x	2.00 in	Horizontal eccentricity		
e_y	0.45 in	Vertical eccentricity		
M_e	120.00 kips-in	Required moment due to eccentricity, $M_e = V * e_x + P * e_y$		
ϕM_n	437.23 kips-in	Allowable shear rupture (punching shear)		

Clip Angle, End Plate

The punching shear limit for a clip angle or end plate connection to a HSS tube wall is checked per eqn (9-29) on page 9-14 of the 15th Edition Steel Construction Manual.

HSS Column Punching Shear		15.00 kips	220.22 kips	0.07	PASS
$R_n = 0.6 * F_y * t * (2 * c_{eff} + 2 * L)$			$\phi = 1.00$	(AISC 15 th Eq.9-29)	
F_y	46.00 ksi	Minimum yield stress of column material			
t	0.29 in	Column wall thickness			
B	14.00 in	Column width			
F_{yb}	36.00 ksi	Minimum yield stress of clip angle material			
t_b	0.38 in	Clip angle thickness			
B_b	8.29 in	Width of clip angle connection			
c_{eff}	1.71 in	Effective width of clip angle per Eq.K1-1, $c_{eff} = \min((10*t/B) * ((F_y * t) / (F_{yb} * t_b)) * B_b, B_b)$			
L	12.00 in	Length of clip angle			
ϕR_n	220.22 kips	Column wall punching shear strength			

AISC 14th and 13th Edition Considerations

Shear Tab

The punching shear limit state for longitudinal plates framing into the sidewall of an HSS member includes the [HSS Limitations](#), as well as a check that the yield strength of the plate does not exceed the rupture capacity of the HSS sidewall.

HSS Punching Shear			FAIL
Check Column Slenderness	Pass	(K1.2)	
E	29000.00 ksi	Modulus of Elasticity	
F_y	42.00 ksi	Column Yield Strength	
t	0.35 in	Column Wall Thickness	
D	14.00 in	Column Outer Diameter	
D/t	40.11	Column Slenderness Ratio	
$(D/t)_{max}$	50.00	Slender Wall Limit (Table K1.1A)	
Check Column Material	Pass	(K1.2)	
F_y	42.00 ksi	Column Yield Strength	
F_{y-max}	52.00 ksi	Column Yield Strength Limit (Table K1.1A)	
Check Column Ductility	Pass	(K1.2) Condition: $F_y/F_u \leq 0.8$	
F_y	42.00 ksi	Column Yield Strength	
F_u	58.00 ksi	Column Tensile Strength	
Check Punching Shear	Fail	(Eqn K1-3)	
F_{yp}	36.00 ksi	Plate Yield Strength	
t_p	0.60 in	Plate Thickness	
t_{p-max}	0.56 in	Maximum Allowed Plate Thickness	

Note:

- The load angle limitation in AISC 360-10, Tables K1.1A and K1.2A is ignored. Otherwise the program would not be able to handle the (common) condition of a large shear force and a small axial force on a Shear Connection.

Clip Angle, End Plate

The punching shear check for columns treats the clip angle or end plate as a "branch" tube of equivalent dimensions. This punching limit state is based on shear yielding of the "chord".

HSS Column Punching Shear		10.000 kips	253.523 kips	0.04	PASS
$R_n = 0.6 * F_y * t * B * (2 * \eta + 2 * \beta_{eop})$			$\Omega = 1.58$ (K2-8)		
F_y	46.000 ksi		Column Yield Strength		
t	0.581 in		Column wall thickness		
B_b	2.000 in		Branch Width		
B	4.000 in		Column width		
β	0.500		Width ratio		
γ	3.442		Column Slenderness Ratio		
l_b	5.000 in		Bearing Length		
η	1.250		Load Length Parameter		
β_{eop}	0.726		Width Ratio (Eqn K2-25)		
R_n/Ω	253.523 kips		Shear punching		

CSA S16-19/14/09 Considerations

Design of HSS connections per the Canadian *CSA S16* design code refers to the *CIDECT Design Guide 3 for Rectangular Hollow Sections* and *CIDECT Design Guide 1 for Circular Hollow Sections*.

Shear Tab

The punching shear limit state for a single plate connection to a HSS tube wall is checked per eqn (7.9) on page 57 for round HSS members and eqn (7.1) on page 75 for rectangular HSS members. These are applicable to HSS Tube and Pipe members with a beam flange (or flange plate) or shear tab connection. The equations in the CIDECT Design Guides check punching shear for shear (longitudinal) plates attached to HSS members by limiting the plate thickness.

HSS Punching Shear			PASS
Check Punching Shear	Pass	Condition: $t_p < t_{limit}$ (CIDECT DG1, Eqn. 7.9)	
t_p	9.52 mm	Plate thickness	
F_{yc}	289.58 MPa	Column yield strength	
F_{yp}	248.21 MPa	Plate yield strength	
t_c	11.81 mm	Column wall thickness	
t_{limit}	15.98 mm	Limit column wall thickness = $1.16 * t_c * (F_{yc}/F_{yp})$	

HSS Punching Shear			PASS
Check Punching Shear	Pass	Condition: $t_p < t_{limit}$ (CIDECT DG3, Eqn. 7.1)	
t_p	9.52 mm	Plate thickness	
F_{yc}	317.16 MPa	Column yield strength	
F_{yp}	248.21 MPa	Plate yield strength	
t_c	8.86 mm	Column wall thickness	
t_{limit}	13.14 mm	Limit column wall thickness = $1.16 * t_c * (F_{yc}/F_{yp})$	

Clip Angle, HSS T-Connection

The punching shear limit state for a clip angle connection a HSS tube wall is checked per CIDECT Design Guide 3 Table 4.1 for rectangular HSS members.

HSS Column Punching Shear		88.96 kN	995.58 kN	0.09	PASS
$N_i = \phi * (0.58 * F_{yc} * t_c * l_{p,eff}) / \sin \theta$			$\phi = 1.0$	<i>(CIDECT DG3, Table 4.1)</i>	
Check Applicability	Check Req'd	<i>Condition: $b_i \leq b_c - 2 * t_c$ (CIDECT DG3, Table 4.1)</i>			
b_{ca}	101.60 mm	<i>Single clip angle leg length perpendicular to the connection plane</i>			
t_{bw}	7.49 mm	<i>Beam web thickness</i>			
b_i	210.69 mm	<i>Clip angle connection width = $2 * b_{ca} + t_{bw}$</i>			
b_c	254.00 mm	<i>Column width</i>			
t_c	7.39 mm	<i>Column wall thickness</i>			
Because $b_i \leq b_c - 2 * t_c$, the check for HSS Column Punching Shear is required					
F_{yc}	317.16 MPa	<i>Column yield strength</i>			
$b_{e,p}$	61.31 mm	<i>Effective punching shear width, $b_{e,p} = \min(b_p (10 * b_p) / (b_c / t_c))$</i>			
h_a	304.80 mm	<i>Clip angle length</i>			
θ	90.00 degrees	<i>Angle between axial load and column</i>			
$l_{p,eff}$	732.22 mm	<i>Effective brace perimeter, $l_{p,eff} = ((2 * h_a) / \sin \theta) + 2 * b_{e,p}$</i>			
N_i	995.58 kN	<i>Axial joint resistance due to chord punching shear</i>			

Through-Plate Welds

See the [Welds](#) topic for information on the through-plate weld.

HSS Transverse Plastification

AISC 15th (360-16) Edition Considerations

The Transverse Plastification limit for a HSS tube wall is checked per eqn (9-30) on page 9-16 of the 15th Edition Steel Construction Manual.

HSS Column Transverse Plastification		15.00 kips	40.37 kips	0.37	PASS
$R_n = (0.5*t^2*F_y) * ((a+b)*4*((T*a*b)/(a+b))^{0.5} + L)/(a*b)*Q_f$			$\phi = 1.00$	(AISC 15 th Eq.9-30)	
F_y	46.00 ksi	Minimum yield stress of column material			
B	14.00 in	Column width			
t	0.29 in	Column wall thickness			
L	12.00 in	Length of clip angle			
T	13.13 in	Unbraced length of HSS column face (AISC 15 th Fig.9-5), $T = B - 3*t$			
a	2.42 in	Distance from left side to edge of clip angle (AISC 15 th Fig.9-5)			
b	2.42 in	Distance from right side to edge of clip angle (AISC 15 th Fig.9-5)			
c	8.29 in	Width of clip angle connection			
P_c	50.00 kips	Column force (user input)			
M_c	48.00 kips-in	Column moment (user input)			
V	80.00 kips	Required shear load			
P	15.00 kips	Required axial load (compression)			
e_x	3.00 in	Horizontal eccentricity			
e_y	0.45 in	Vertical eccentricity			
M_r	246.75 kips-in	Moment due to eccentricity, $M_r = V*e_x + P*e_y $			
A_g	15.70 in ²	Gross cross-sectional area of the member			
F_c	46.00 ksi	Available stress in main member, LRFD (AISC 15 th p.9-15)			
S	70.00 in ³	Elastic section modulus about the axis of bending			
U	0.27	Utilization ratio (AISC 15 th p.9-15), $U = (P_c + V)/(F_c*A_g) + (M_c + M_r)/(F_c*S)$			
Q_f	0.90	Column stress interaction parameter (compression), per Eqn (K2-3), $Q_f = 1 - 0.3*U*(1 + U)$			
ϕR_n	40.37 kips	Transverse plastification strength			

AISC 14th and 13th Edition Considerations

Shear Tab

This limit state checks the sidewall for plastification due to axial force in the beam per AISC 360 Chapter K or CIDECT DG 3 Table 7.1.

HSS Transverse Plastification		7.000 kips	7.233 kips	0.97	PASS
$R_n = 5.5*F_y*t^2*(1+0.25*N/D)*Q_f$			$\Omega = 1.67$	(K1-8)	
F_y	42.000 ksi	Column Yield Strength			
t	0.233 in	Column Wall Thickness			
N	12.000 in	Plate Length			
D	16.000 in	Column Outer Diameter			
Q_f	0.811	Chord Stress Interaction Parameter (Eqn K2-1)			
F_c	25.200 ksi	Available Stress			
A_g	11.500 in ²	Column Cross-Sectional Area			
S	44.875 in ³	Column Section Modulus			
U	0.438	Utilization Ratio (Eqn K2-2)			
R_n/Ω	7.233 kips	Transverse Plastification			

Note:

- For round HSS (Pipe) columns, this limit state is checked regardless of whether axial force is present, because its capacity is used in the flexural plastification check.
- For rectangular HSS (Tube) columns, this limit state is only applicable when there is axial load in the connection.

Clip Angle, End Plate

This limit state treats the clip angle or end plate as a "branch" tube of equivalent dimensions. This limit state is based on plastification of the "chord".

HSS Column Transverse Plastification		10.00 kips	62.98 kips	0.16	PASS
$R_n = F_y * t^2 * ((2 * \eta) / (1 - \beta) + 4 / (1 - \beta)^{0.5}) * Q_f$			$\phi = 1.0$	(K2-7)	
B_b	6.29 in	Branch width			
B	9.00 in	Column width			
β	0.70	Width ratio			
F_y	46.00 ksi	Column yield strength			
t	0.29 in	Column wall thickness			
l_b	12.00 in	Bearing length			
η	1.33	Load length parameter			
A_g	9.92 in ²	Column cross-sectional area			
S	27.56 in ³	Column section modulus			
U	0.11	Utilization ratio (Eq K1-6)			
Q_f	1.00	Chord stress interaction parameter			
ϕR_n	62.98 kips	Transverse plastification			

CSA S16-19/14/09 Considerations

Shear Tab

This limit state checks the HSS member face for plastification due to axial force in the beam. For pipe HSS members (CHS) this limit state is checked per CIDECT DG1 Table 7.1, page 55.

HSS Transverse Plastification		75.00 kN	118.53 kN	0.63	PASS
$N_i = \phi * Q_u * Q_f * ((F_{yc} * t_c^2) / \sin\theta)$			$\phi = 1.00$	(CIDECT DG1 Table 7.1)	
h_p	304.80 mm	Longitudinal plate length			
D	244.60 mm	Column outer diameter			
η	1.25	Longitudinal plate aspect ratio, $\eta = h_p / D$			
Q_u	7.49	Function to account for the effect of geometric parameters, $Q_u = 5 * (1 + 0.4 * \eta)$			
Q_f	1.00	User input column stress interaction parameter			
F_{yc}	289.58 MPa	Column yield strength			
t_c	7.39 mm	Column wall thickness			
θ	90.00 degrees	Angle between axial load and column			
N_i	118.53 kN	Axial joint resistance due to transverse plastification			

For rectangular HSS members (RHS), this limit state is checked per CIDECT DG3 Table 7.1, page 77.

HSS Transverse Plastification	111.21 kN	157.62 kN	0.71	PASS
$N_i = \phi * 2 * F_{yc} * t_c^2 * (\eta + 2 * (1 - t_p / b_c)^{0.5}) * Q_f$		$\phi = 1.00$	<i>(CIDECT DG3 Table 7.1)</i>	
F_{yc}	317.16 MPa	<i>Column yield strength</i>		
t_c	8.86 mm	<i>Column wall thickness</i>		
h_p	304.80 mm	<i>Longitudinal plate length</i>		
b_c	254.00 mm	<i>Column face width</i>		
η	1.20	<i>Longitudinal plate aspect ratio, $\eta = h_p / b_c$</i>		
t_p	9.52 mm	<i>Plate thickness</i>		
Q_f	1.00	<i>User input column stress interaction parameter</i>		
N_i	157.62 kN	<i>Axial joint resistance due to transverse plastification</i>		

Note:

- For a shear tab connection with a through plate, a ratio of 4 will be used instead of 2 according to CIDECT DG3 Table 7.1, page 78.

Clip Angle, HSS T-Connection

This limit state treats the clip angle as a "branch" tube of equivalent dimensions. This limit state is based on the plastification of the "chord" face per CIDECT DG3 Table 4.1, page 36.

HSS Column Transverse Plastification	50.00 kN	411.76 kN	0.12	PASS
$N_i = \phi * Q_u * Q_f * ((F_{yc} * t_c^2) / \sin\theta)$		$\phi = 1.0$	<i>(CIDECT DG3, Table 4.1)</i>	
Check Applicability	Check Req'd	<i>Condition: $\beta \leq 0.85$ (CIDECT DG3, Table 4.1)</i>		
b_{ca}	101.60 mm	<i>Single clip angle leg length perpendicular to the connection plane</i>		
t_{bw}	7.49 mm	<i>Beam web thickness</i>		
b_i	210.69 mm	<i>Clip angle connection width = $2 * b_{ca} + t_{bw}$</i>		
b_c	254.00 mm	<i>Column width</i>		
β	0.83	<i>Clip angle connection width to column width ratio, $\beta = b_i / b_c$</i>		
Because $\beta \leq 0.85$, the check for HSS Column Transverse Plastification is required				
h_a	304.80 mm	<i>Clip angle length</i>		
η	1.20	<i>Ratio of clip angle length to column width, $\eta = h_a / b_c$</i>		
θ	90.00 degrees	<i>Angle between axial load and column</i>		
Q_u	23.76	<i>Function to account for the effect of geometric parameters, $Q_u = ((2 * \eta) / (1 - \beta) * \sin \theta) + (4 / (1 - \beta)^{0.5})$</i>		
Q_f	1.00	<i>Column stress interaction parameter (user input)</i>		
F_{yc}	317.16 MPa	<i>Column yield strength</i>		
t_c	7.39 mm	<i>Column wall thickness</i>		
N_i	411.76 kN	<i>Axial joint resistance due to transverse plastification</i>		

Note:

- For cases where the clip angle "branch" is equivalent to a square tube, the "chord" face plastification is checked per CIDECT DG3 Table 4.2, page 39.

HSS Flexural Plastification

AISC 15th (360-16) Edition Considerations

The Flexural Plastification limit for a HSS tube wall is checked per eqn (9-34) on page 9-16 of the 15th Edition Steel Construction Manual.

HSS Column Flexural Plastification		246.75 kips-in	218.51 kips-in	1.13	FAIL
$M_n = (0.25*t^2*F_y)*((4*(a*b*c*T*\rho)^{0.5} + L*\rho)/(a*b))*Q_f$			$\phi = 1.00$	(AISC 15 th Eq.9-34)	
P	15.00 kips	Required axial load (compression)			
V	80.00 kips	Required shear load			
e _x	3.00 in	Horizontal eccentricity			
e _y	0.45 in	Vertical eccentricity			
M _e	246.75 kips-in	Required moment due to eccentricity, $M_e = V*e_x + P*e_y $			
F _y	46.00 ksi	Minimum yield stress of column material			
B	14.00 in	Column width			
t	0.29 in	Column wall thickness			
L	12.00 in	Length of clip angle			
T	13.13 in	Unbraced length of HSS column face (AISC 15 th Fig.9-5), $T = B - 3*t$			
a	2.42 in	Distance from left side to edge of clip angle (AISC 15 th Fig.9-5)			
b	2.42 in	Distance from right side to edge of clip angle (AISC 15 th Fig.9-5)			
c	8.29 in	Width of clip angle connection			
ρ	51.76 in ²	Yield line factor (AISC 15 th Eq.9-36), $\rho = 2*a*b + a*c + b*c$			
P _c	50.00 kips	Column force (user input)			
M _c	48.00 kips-in	Column moment (user input)			
F _c	46.00 ksi	Available stress in main member, LRFD (AISC 15 th p.9-15)			
A _g	15.70 in ²	Column cross-sectional area			
S	70.00 in ³	Column section modulus			
U	0.08	Utilization ratio (AISC 15 th p.9-15), $U = P_c /(F_c*A_g) + M_c /(F_c*S)$			
Q _f	0.97	Column stress interaction parameter (compression) per Eqn (K2-3), $Q_f = 1 - 0.3*U*(1 + U)$			
φM _n	218.51 kips-in	Out of plane flexural plastification strength			

AISC 14th and 13th Edition Considerations

Shear Tab

This limit state checks the sidewall for plastification due to bending moment caused by eccentricity in the connection to the beam per AISC 360 Chapter K. This check is only applicable to round HSS (Pipe) columns. It is not included when the column is a rectangular HSS (Tube). Per the AISC 360-16 "Yielding (plastification) of the HSS face has not been a governing limit state in physical tests."

HSS Flexural Plastification	213.150 kips-in	104.278 kips-in	2.04	FAIL
$M_n = 0.8 * I_b * R_n$		$\phi = 0.9$		
I_b	12.000 in	Plate Length		
e_x	3.500 in	Horizontal eccentricity		
e_y	0.450 in	Vertical eccentricity		
R_n	12.069 kips	Transverse Plastification Capacity		
M_{req}	213.150 kips-in	Required Flexural Plastification = $V * e_x + P * e_y$		
ϕM_n	104.278 kips-in	Flexural Plastification		

Clip Angle, End Plate

The flexural plastification check for columns treats the clip angle or end plate as a "branch" tube of equivalent dimensions. This limit state is based on plastification of the "chord". The flexure is caused by eccentricity in the connection to the beam.

HSS Column Flexural Plastification	39.500 kips-in	296.500 kips-in	0.13	PASS
$M_n = F_y * t^2 * H_b * (1 / (2 * \eta) + 2 / (1 - \beta)^{0.5} + \eta / (1 - \beta)) * Q_f$		$\Omega = 1.5$	(K3-6)	
B_b	2.000 in	Branch Width		
B	4.000 in	Column width		
β	0.500	Width ratio		
F_y	46.000 ksi	Column Yield Strength		
t	0.581 in	Column wall thickness		
H_b	5.000 in	Bearing Length		
η	1.250	Load length parameter		
A_g	21.000 in ²	Column Cross-Sectional Area		
S	67.375 in ³	Column Section Modulus		
U	0.248	Utilization Ratio (Eq K1-6)		
Q_f	1.000	Chord Stress Interaction Parameter		
M_n / Ω	296.500 kips-in	Flexural plastification		

CSA S16-19/14/09 Considerations

Shear Tab

The Flexural Plastification limit state is only required for pipe HSS members and is checked per CIDECT DG1 Table 7.1, page 55. For a column/beam shear tab connection, the required moment, M_{req} , is taken as the same load required by the AISC HSS Flexural Plastification check. For braced connections, this moment is calculated.

HSS Flexural Plastification		14.42 kN-m	28.90 kN-m	0.50	PASS
$M_i = \phi * 0.8 * Q_u * Q_f * F_{yc} * t_c^2 * h_p$			$\phi = 1.00$	<i>(CIDECT DG1 Table 7.1)</i>	
h_p	304.80 mm	<i>Longitudinal plate length</i>			
D	244.60 mm	<i>Column outer diameter</i>			
η	1.25	<i>Longitudinal plate aspect ratio, $\eta = h_p / D$</i>			
Q_u	7.49	<i>Function to account for the effect of geometric parameters, $Q_u = 5 * (1 + 0.4 * \eta)$</i>			
Q_f	1.00	<i>User input column stress interaction parameter</i>			
F_{yc}	289.58 MPa	<i>Column yield strength</i>			
t_c	7.39 mm	<i>Column wall thickness</i>			
V	266.89 kN	<i>User input shear load</i>			
P	-75.00 kN	<i>User input axial load</i>			
ex	50.80 mm	<i>Horizontal eccentricity</i>			
ey	11.43 mm	<i>Vertical eccentricity</i>			
M_{req}	14.42 kN-m	<i>Required flexural plastification = $V * ex + P * ey$</i>			
M_i	28.90 kN-m	<i>Axial joint resistance due to flexural plastification</i>			

Clip Angle, HSS T-Connection

This limit state treats the clip angle as a "branch" tube of equivalent dimensions. This limit state is based on the plastification of the "Chord" face due to in-plane bending per CIDECT DG3 eqn 5.2, page 61. For column/beam clip angle and brace connections, the required moment, M_{req} , is taken as the same load required by the AISC HSS Flexural Plastification check. For HSS T-connections, the required moment is the user-input branch moment.

HSS Column Flexural Plastification		27.69 kN-m	64.95 kN-m	0.43	PASS
$M_i = \phi * F_{yc} * t_c^2 * h_a * ((1/(2*\eta)) + (2/(1 - \beta)^{0.5}) + (\eta / (1 - \beta))) * Q_f$			$\phi = 1.0$	<i>(CIDECT DG3, Eqn 5.2)</i>	
Check Applicability	Check Req'd	<i>Condition: $\beta \leq 0.85$ (CIDECT DG3, Eqn 5.2)</i>			
b_{ca}	101.60 mm	<i>Single clip angle leg length perpendicular to the connection plane</i>			
t_{bw}	7.49 mm	<i>Beam web thickness</i>			
b_i	210.69 mm	<i>Clip angle connection width = $2*b_{ca} + t_{bw}$</i>			
b_c	254.00 mm	<i>Column width</i>			
β	0.83	<i>Clip angle connection width to column width ratio, $\beta = b_i / b_c$</i>			
Because $\beta \leq 0.85$, the check for HSS Column Flexural Plastification is required					
F_{yc}	317.16 MPa	<i>Column yield strength</i>			
t_c	7.39 mm	<i>Column wall thickness</i>			
h_a	304.80 mm	<i>Clip angle length</i>			
η	1.20	<i>Ratio of clip angle length to column width, $\eta = h_a / b_c$</i>			
Q_f	1.00	<i>Column stress interaction parameter (user input)</i>			
V	355.86 kN	<i>User input shear load</i>			
P	50.00 kN	<i>User input axial load</i>			
e_x	76.20 mm	<i>Horizontal eccentricity</i>			
e_y	11.43 mm	<i>Vertical eccentricity</i>			
M_{req}	27.69 kN-m	<i>Required flexural plastification = $V*e_x + P*e_y$</i>			
M_i	64.95 kN-m	<i>Flexural joint resistance due to flexural plastification</i>			

HSS Sidewall Local Axial Yielding

CSA S16-19/14/09 Considerations

Clip Angle, HSS T-Connection

This limit state treats the clip angle as a "branch" tube of equivalent dimensions. This limit state is based on the side wall failure of the "Chord" per CIDECT DG3 Table 4.1, page 36.

HSS Column Sidewall Local Axial Yielding		142.34 kN	2725.98 kN	0.05	PASS
$N_i = \phi * (f_k * t_c * b_w * Q_f) / \sin\theta$		$\phi = 1.0$		<i>(CIDECT DG3, Table 4.1)</i>	
Check Applicability	Check Req'd	<i>Condition: $0.95 \leq \beta \leq 1.05$ (CIDECT DG3, Table 4.1)</i>			
b_{ca}	101.60 mm	<i>Single clip angle leg length perpendicular to the connection plane</i>			
t_{bw}	7.49 mm	<i>Beam web thickness</i>			
b_i	210.69 mm	<i>Clip angle connection width = $2*b_{ca} + t_{bw}$</i>			
b_c	203.20 mm	<i>Column width</i>			
β	1.04	<i>Clip angle connection width to column width ratio, $\beta = b_i / b_c$</i>			
Because $0.95 \leq \beta \leq 1.05$, the check for HSS Column Sidewall Local Axial Yielding is required					
F_{yc}	317.16 MPa	<i>Column yield strength</i>			
h_a	304.80 mm	<i>Clip angle length</i>			
t_c	11.81 mm	<i>Column wall thickness</i>			
θ	90.00 degrees	<i>Angle between axial load and column</i>			
χ	1.00	<i>Reduction factor for column buckling (user input)</i>			
f_k	317.16 MPa	<i>Buckling stress, $f_k = \chi * F_{yc}$</i>			
b_w	727.71 mm	<i>Variable to determine chord wall side failure, $b_w = ((2*h_a)/\sin\theta) + 10*t_c$</i>			
Q_f	1.00	<i>Column stress interaction parameter (user input)</i>			
N_i	2725.98 kN	<i>Axial joint resistance due to column sidewall local yielding</i>			

HSS Sidewall Local Flexural Yielding

AISC 14th and 13th Edition Considerations

Clip Angle, End Plate

The sidewall local yielding check for columns treats the clip angle or end plate as a "branch" tube of equivalent dimensions. This limit state is based on yielding of the "chord". The flexure is caused by eccentricity in the connection to the beam.

HSS Column Sidewall Local Yielding		39.500 kips-in	835.041 kips-in	0.05	PASS
$M_n = 0.5 * F_y * t * (H_b + 5 * t)^2$		$\Omega = 1.50$		<i>(K3-7)</i>	
F_y	46.000 ksi	<i>Column Yield Strength</i>			
t	0.581 in	<i>Column wall thickness</i>			
H_b	5.000 in	<i>Branch Depth</i>			
M_{req}	39.500 kips-in	<i>Required moment</i>			
M_n/Ω	835.041 kips-in	<i>Available moment</i>			

CSA S16-19/14/09 Considerations

Clip Angle, HSS T-Connection

This limit state treats the clip angle as a "branch" tube of equivalent dimensions. This limit state is based on the side wall failure of the "Chord" due to in-plane bending per CIDECT DG3 eqn 5.1, page 63.

HSS Column Sidewall Local Flexural Yielding		31.96 kN-m	45.46 kN-m	0.70	PASS
$M_i = \phi * 0.5 * f_k * t_c * (h_a + 5 * t_c)^2 * Q_f$			$\phi = 1.0$	<i>(CIDECT DG3, Table 5.1)</i>	
Check Applicability	Check Req'd	<i>Condition: $0.95 \leq \beta \leq 1.05$ (CIDECT DG3, Table 5.1)</i>			
b_{ca}	63.50 mm	<i>Single clip angle leg length perpendicular to the connection plane</i>			
t_g	24.00 mm	<i>Gusset thickness</i>			
b_i	151.00 mm	<i>Clip angle connection width = $2 * b_{ca} + t_g$</i>			
b_c	152.40 mm	<i>Column width</i>			
β	0.99	<i>Clip angle connection width to column width ratio, $\beta = b_i / b_c$</i>			
Because $0.95 \leq \beta \leq 1.05$, the check for HSS Column Sidewall Local Flexural Yielding is required					
F_{yc}	317.16 MPa	<i>Column yield strength</i>			
h_a	190.50 mm	<i>Clip angle length</i>			
t_c	5.92 mm	<i>Column wall thickness</i>			
f_k	317.16 MPa	<i>Buckling stress, $f_k = F_{yc}$</i>			
Q_f	1.00	<i>Column stress interaction parameter (user input)</i>			
M_i	45.46 kN-m	<i>Flexural joint resistance due to column sidewall local yielding</i>			

Branch Axial Yield

CSA S16-19/14/09 Considerations

HSS T-Connection

This limit state is based on the local yielding of the branch due to axial load per CIDECT DG3 Table 4.1, page 36.

Branch Axial Yield		66.72 kN	1678.51 kN	0.04	PASS
$N_i = \phi * F_{yb} * t_b * l_{b,eff}$			$\phi = 1.0$	<i>(CIDECT DG3, Table 4.1)</i>	
F_{yb}	344.74 MPa	<i>Branch yield strength</i>			
F_{yc}	344.74 MPa	<i>Chord yield strength</i>			
t_b	7.94 mm	<i>Branch wall thickness</i>			
t_c	9.52 mm	<i>Chord wall thickness</i>			
h_b	254.00 mm	<i>Branch depth</i>			
b_b	152.40 mm	<i>Branch width</i>			
b_c	254.00 mm	<i>Chord width</i>			
b_e	68.58 mm	<i>Effective width of the branch face welded to the chord, $b_e = \min(b_b, (10 / (b_c / t_c)) * (F_{yc} * t_c) / (F_{yb} * t_b)) * b_b$</i>			
$l_{b,eff}$	613.41 mm	<i>Effective branch perimeter, $l_{b,eff} = 2 * h_b + 2 * b_e - 4 * t_b$</i>			
N_i	1678.51 kN	<i>Axial joint resistance due to branch yield</i>			

Branch Flexural Yield

CSA S16-19/14/09 Considerations

HSS T-Connection

This limit state is based on the local yielding of the branch due to in-plane bending per CIDECT DG3 Table 5.1, page 63.

Branch Flexural Yield	14.12 kN-m	185.59 kN-m	0.08	PASS
$M_i = \phi * F_{yb} * [W_{plb} - (1 - b_e / b_b) * b_b * (h_b - t_b) * t_b]$		$\phi = 1.0$	<i>(CIDECT DG3, Table 5.1)</i>	
Check Applicability	Check Req'd	<i>Condition: $0.85 < \beta \leq 1.0$ (CIDECT DG3, Table 5.1)</i>		
b_b	254.00 mm	<i>Branch width</i>		
b_c	254.00 mm	<i>Chord width</i>		
β	1.00	<i>Branch width to chord width ratio, $\beta = b_b / b_c$</i>		
Because $0.85 < \beta \leq 1.0$, the check for Branch Flexural Yield is required				
F_{yb}	344.74 MPa	<i>Branch yield strength</i>		
F_{yc}	344.74 MPa	<i>Chord yield strength</i>		
t_b	17.73 mm	<i>Branch wall thickness</i>		
t_c	9.52 mm	<i>Chord wall thickness</i>		
h_b	254.00 mm	<i>Branch depth</i>		
W_{plb}	1387984.32 mm ³	<i>Plastic section modulus of branch about the axis of bending</i>		
b_e	51.17 mm	<i>Effective width of the branch face welded to the chord, $b_e = \min(b_b, (10/(b_c/t_c)) * (F_{yc} * t_c) / (F_{yb} * t_b) * b_b)$</i>		
M_i	185.59 kN-m	<i>Flexural joint resistance due to branch yield</i>		

HSS Combined Interaction

The combination of transverse loads and bending loads on an HSS member is checked to ensure that a combined failure of multiple limit states does not occur at loads that would not fail either limit state by itself. The controlling transverse strength and the controlling flexural strength are used for this check, based on the limit state for each failure mode that has the lowest capacity.

AISC 14th and 13th Edition Considerations

HSS Combined Interaction		0.57	PASS
$P_r / (\phi P_n) + M_r / (\phi M_n) \leq 1.0$		<i>(K3-13)</i>	
P_r	10.00 kips	<i>Required axial strength</i>	
ϕP_n	62.98 kips	<i>Design axial strength from Table K2.2</i>	
M_r	164.50 kips-in	<i>Required flexural strength</i>	
ϕM_n	395.42 kips-in	<i>Design flexural strength from Table K3.2</i>	
UC	0.57	<i>Unity check per interaction equation (Eqn K3-13)</i>	

CSA S16-19/14/09 Considerations

HSS Combined Interaction		1.01	FAIL
$N_r / N_i + M_r / M_i \leq 1.0$		<i>(CIDECT DG3, Eqn 5.9)</i>	
N_r	251.63 kN	<i>Required axial strength</i>	
N_i	826.23 kN	<i>Minimum available axial strength</i>	
M_r	31.96 kN-m	<i>Required flexural strength</i>	
M_i	45.46 kN-m	<i>Minimum available flexural strength</i>	
UC	1.01	<i>Unity check per interaction equation (Eqn 5.9)</i>	

HSS Beam to Column Moment Connection

The HSS Beam to Column Moment Connection is designed per AISC 15th Edition Chapter K and AISC Design Guide 24, 2nd Edition, Chapters 9 and 10. This connection uses direct welds between rectangular HSS members to resist in-plane moment, axial load, and shear without additional stiffening plates.

Naming Conventions:

- This connection adapts the same checks used for HSS T-Connections. “Branch” and “Chord” simply become “Beam” and “Column.”

Limitations:

- In-plane moment only (out-of-plane moments not checked)
- Single-sided connections only
- Non-seismic applications only

Key Implementation Details

Unbraced Length Parameter (T)

RISACONNECTION uses $T = B$ (column width) for all calculations per AISC 360-16 and DG-24.

Prior versions of RISACONNECTION used $T = B - 3t$ for HSS T-Connections. This has been updated to $T = B$ to align with AISC 360-16 Limit State Tables and DG-24 provisions. This change affects:

- Column Transverse Plastification
- Column Flexural Plastification
- Related geometric parameters (a, b dimensions)

End Distance Capacity Reductions

When the connection is located near the top of the column, certain limit state capacities are multiplied by 0.50 per AISC 360-16 pg. 16.1-463:

- Column Transverse Plastification
- Column Flexural Plastification
- Column Punching Shear (Axial)

This reduction accounts for reduced confinement near the free edge of the column.

Resistance Factors

RISACONNECTION uses resistance factors from AISC 360-16 rather than DG-24 in cases where they differ:

Check	DG-24 RISACConnection		Reason
Beam Local Yielding (Axial)	$\phi = 0.95$	$\phi = 0.90$	Per AISC Spec. J4-1 and STI Technical Paper
Column Sidewall Local Crippling	$\phi = 0.75$	$\phi = 0.80$	Per AISC Spec. J10-4

Column Stress Interaction Parameter (Qf)

The Qf factor accounts for axial stress in the column per AISC Eq. K2-3. RISACConnection handles this as follows:

- Standalone Mode: User input in the Loading section (defaults to 1.0 if not specified)
- RISA-3D/RISAFloor Integration: Automatically calculated based on column utilization ratio

Qf is used in the following checks:

- Column Transverse Plastification
- Column Sidewall Local Crippling
- Column Flexural Plastification

Applicability Logic (When Checks Report "NA")

Many checks include complex applicability rules based on geometric parameters. The program reports checks as "NA" (Not Applicable) when geometric conditions fall outside the scope of the design provisions.

Checks Not Included

The following checks discussed in AISC Commentary are not included in RISACConnection:

Column Sidewall Local Buckling (Axial and Moment):

Per AISC 360-16 Comm. J10.5 and AISC Spec. Eq. J10-8, sidewall buckling checks apply to matched-width cross-connections ($\beta = 1.0$) when moment is equilibrated by beams on both sides of the column. RISACConnection does not include this check because:

- The program supports single-sided connections only
- No information is available about the presence/absence of an opposite beam
- Including this check would be over-conservative for single-sided connections

Welds to Face of HSS

See the [Welds](#) topic for information on welds to the face of an HSS member.

Knife Plate or End Tee Unbraced Lengths

The unbraced length for an HSS brace to gusset connection is defined as the distance from the face of the HSS to the centroid of the fastener group as shown in the image below:

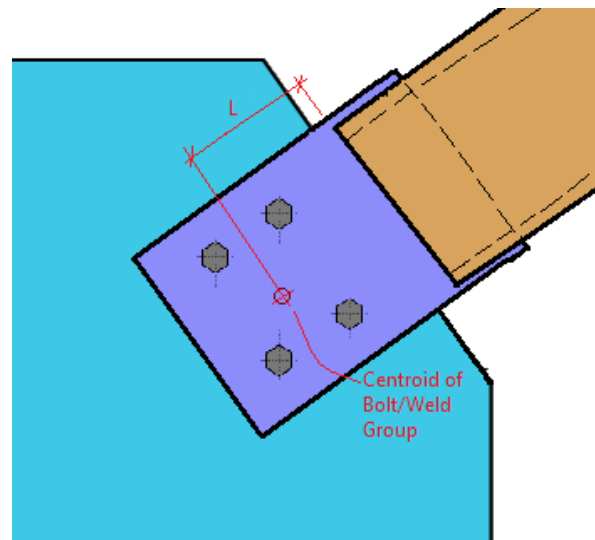

The appropriate unbraced length to use in the compression check for this plate or Tee Stem is a matter of engineering judgment. Therefore, RISACONNECTION provides an "Effective Length Factor" that can be used to adjust this unbraced length up or down if desired. The default value for this effective length factor is 2.1.

Column Stress Interaction Parameter, Q_f

Both the AISC Chapter K Tables and CIDECT DG 3 Table 7.1 include a column stress interaction parameter, Q_f . There are some cases where RISACONNECTION cannot determine this value, so it relies on the user adjusting this in the **Loading** input properties:

Loading	
Shear Load, kN.	250.000
Axial Load, kN.	50.000
Moment Load, kN-m.	200.000
Top Column Dist, mm.	508.000
Column Force, kN.	222.411
Story Shear, kN.	0.000
Q_f	1.000

Column Buckling Reduction Factor, χ

The CIDECT DG3 Table 4.1 includes a column buckling reduction factor, χ , in the HSS Column Sidewall Local Axial Yielding limit state. This is a user input located in the Loading input properties and is used for Clip Angle and HSS T-Connections when the axial load is in compression.

Loading	
Branch Shear (In-Plane), kN.	222.411
Branch Axial, kN.	50.000
Branch Moment (In-Plane), kN-n	14.123
Q_f , Coeff.	1.000
χ , Coeff.	1.000

Design Checks for Moment Connections

These checks are unique to certain types of moment connections. Moment checks that are standard bolt and material checks, see the [Bolt & Material Checks](#) topic. For weld information, see the [Weld Checks](#) topic.

Required Flange Force

All moment connections can resist axial, shear, and moment forces. The axial and moment force is converted into a Required Flange Force (Tension and Compression) which is reported at the top of the results Report. This value (sometimes tension, sometimes compression) is then compared to the Available capacity of each limit state in the Unity Check value.

Material Properties:				
Column	W14X90	A992	$F_y = 50.000$ ksi	$F_u = 65.000$ ksi
Beam	W16X31	A992	$F_y = 50.000$ ksi	$F_u = 65.000$ ksi
Plate	P0.38X6.00X22.00	A36	$F_y = 36.000$ ksi	$F_u = 58.000$ ksi
Input Data:				
Shear Load	200.000 kips	<i>User Input Shear Load</i>		
Moment	200.000 kips-ft	<i>User Input Moment</i>		
Axial Load	50.000 kips	<i>User Input Axial Force (compression)</i>		
Puf_c	180.239 kips	<i>Required Flange Force (compression)</i>		
Puf_t	130.239 kips	<i>Required Flange Force (tension)</i>		
Top Column Dist	20.000 in	<i>User Input Top Column Dist</i>		
Column Force	50.000 kips	<i>User Input Column Force</i>		
Story Shear	0.000 kips	<i>User Input Story Shear</i>		

The Required Flange Force is calculated as:

$$P_{uf} = \frac{Pu}{2} \pm \frac{Mu}{\text{Moment Arm between Flange Forces}}$$

End Plate Moment Checks

These checks are specific only to end plate moment connections. There are several checks for plate failure in an end-plate moment connection. These checks are outlined below. All design procedures and equation references, unless otherwise noted, are taken from AISC Design Guide #4, 2nd Edition. In cases where bolt prying may affect the design, the prying effects are calculated per the procedure in AISC Design Guide #16.

Currently the program can model any type of end plate connections described in the AISC design guides, plus an 8 bolt extended connection not specifically described in the design guides. The yield lines for this "8 Bolt (unstiffened)" connection are taken from Emmet Sumner's PhD thesis ("Unified Design of Extended End- Plate Moment Connections Subject to Cyclic Loading" June 17, 2003) which forms much of the basis for Design Guides 4 and 16. Specifically refer to the MRE 1/2 connection in this paper (section 4.4.4.7 and Figure 4.9) for the end plate yield lines. Similarly refer to the MRE 1/3 connections in Figures 4.10 and 4.11 for the end plate yield lines of the unstiffened and stiffened connections, respectively.

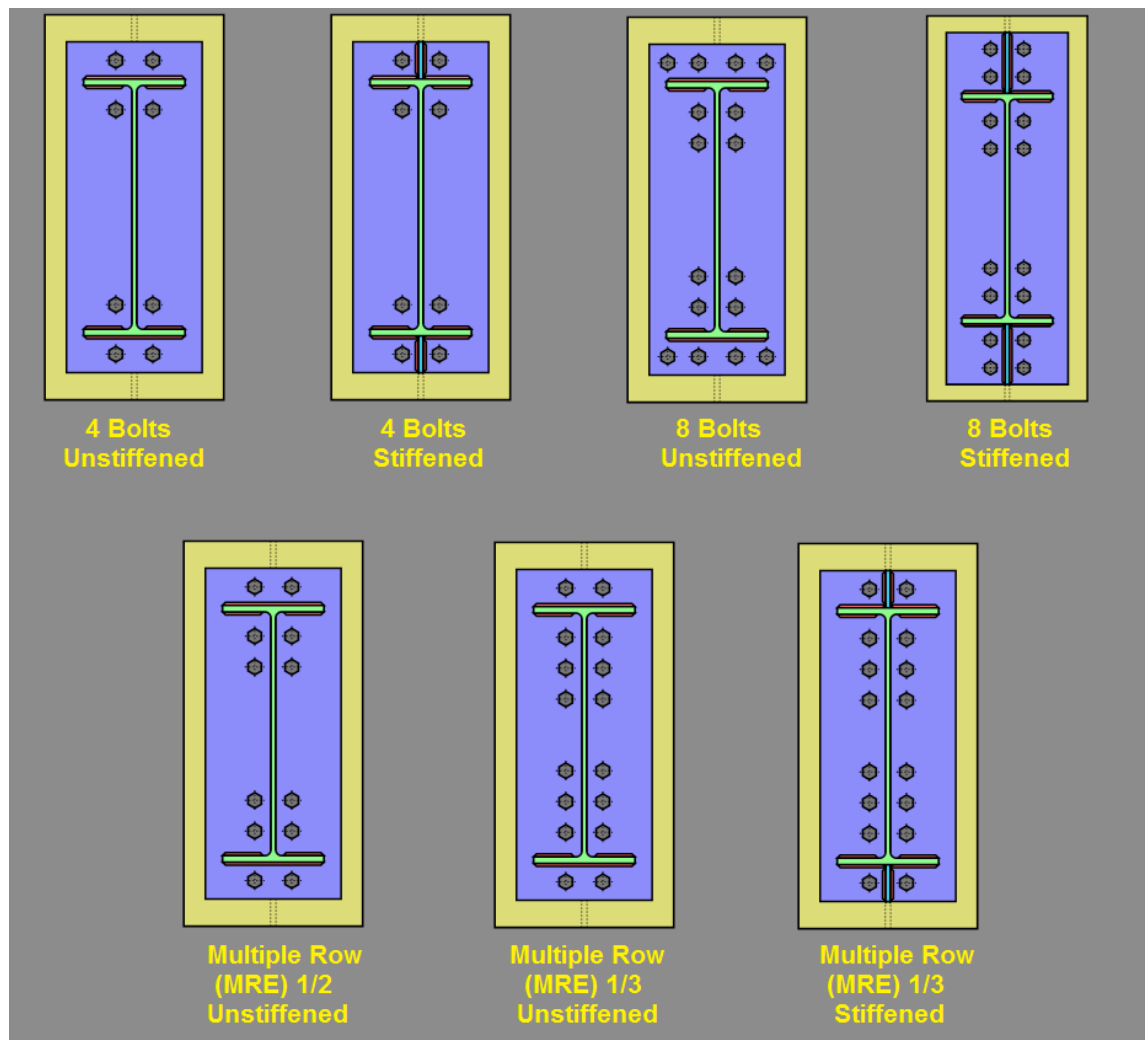

For flush end plate moment connections the γ_r value is always assumed to be equal to 1.25 to limit the connection rotation at ultimate moment and allow the connection to qualify as a fully restrained moment connection.

Note

- There is a discrepancy between the definitions of h_0 , h_1 , h_2 , in the AISC Design Guides for bolted end plate connections. Design Guide 4 is the more recently published document and reflects a more refined procedure. In Design Guide 4, the h values defined are based on the center-line of the compression flange. This represents the point of zero displacement for the derivation of the yield lines. Therefore, the Design Guide 4 definition is the basis for all bolted end plate yield lines used in RISACONNECTION.
- Because design is based on the AISC Design Guide, which assumes that half the bolts are in compression, half are in tension, RISACONNECTION will always check just straight bolt shear (not combined bolt tension and shear). If the user-input loaded results in a large axial tension which puts all bolts into tension, the program results will not change, but a warning will be given to the user in the affected limit states.

Bolt Moment Strength (no prying)

This check is calculated for the bolts in tension on the End Plate Moment Connection. Expand this section of the design report and RISACONNECTION will provide you with the exact equation, code reference, listed variables, as well as the code check value and pass or failure notification.

Bolt Moment Strength (no prying)	127.6197 kips	117.1220 kips	1.09	FAIL
$R_{np} = 2 * R_n * (h_0 + h_1) / d_m$		$\phi = 0.75$	(DG-4-2 nd (3.7))	
R_n	39.7608 kips	Bolt tensile strength. $R_n = F_t * A_b$		
h_0	17.1800 in	Distance from the centerline of the beam compression flange to the centerline of tension bolt row N 0		
h_1	13.1800 in	Distance from the centerline of the beam compression flange to the centerline of tension bolt row N 1		
F_t	90.0000 ksi	Bolt material tensile strength		
A_b	0.4418 in ²	Nominal area of the bolt. $A_b = \pi * d_b^2 / 4$		
d_b	0.7500 in	Bolt diameter		
d_m	15.4600 in	Moment arm between the flange forces		
ϕF_{np}	117.1220 kips	Bolt tensile strength (no prying)		
d_m	15.4600 in	Moment arm between the flange forces		
R_{req}	127.6197 kips	Required Flange Force (worst) in bolts due to moment		

The moment capacity for this check is based on Bolt Tensile Strength from section J3.6 of the AISC 360-10 specification and the Bolt Tension Strength equations (3.7 and 3-8) from the AISC Steel Design Guide 4 (Second Edition). The variables are displayed graphically on page 15 of the Design Guide in Figure 2.7.

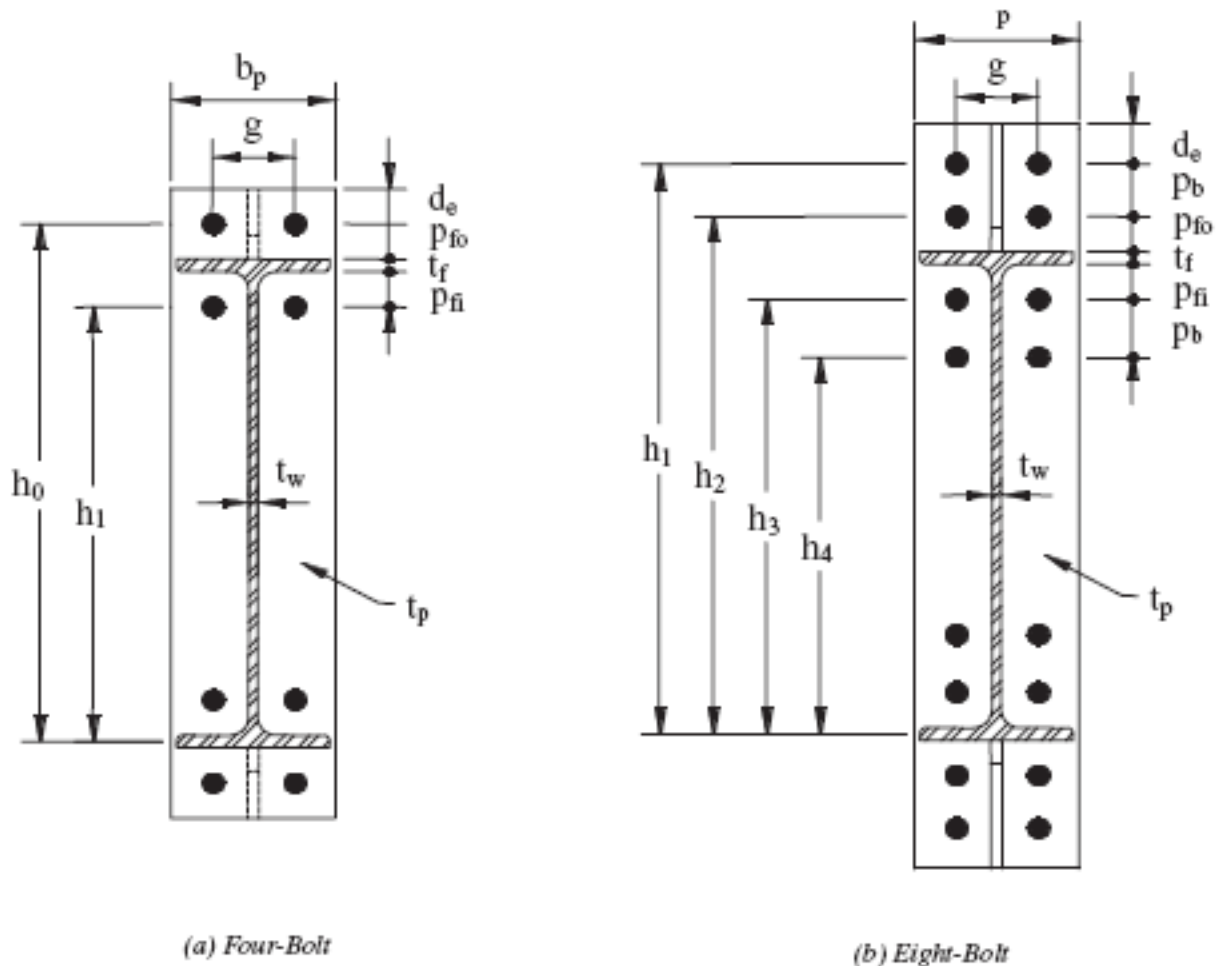

Fig. 2.7. End plate geometry.

Note:

- The 4 bolt connections will automatically consider bolt prying action if applicable.
- When a thin column flange results in bolt prying, it is recommended that stiffeners be provided to prevent prying. If not then the Qmax values calculated will be based on the same formulas given for end plates, but using the column flange properties instead.
- The 8 bolt connections will fail the connection whenever it is determined that bolt prying must be considered. This is because Design Guide 16 does not provide Qmax formulas for the 8 bolt connections.

Verify Bolt Prying Assumption

The [Bolt Moment Strength](#) check varies depending on whether there is prying force action or not. Therefore, the program reports this section to show the calculations which determined what Bolt Moment Strength check was used.

Verify Bolt Prying Assumption		FAIL
Condition for check plate behavior thick : $\phi F_{pl} \geq 1.1 * \phi F_{np}$		<i>(DG-4-2nd (3.33), (3.35))</i>
Condition for check flange column behavior thick : $\phi F_{cf} \geq 1.1 * \phi F_{np}$		
ϕF_{np}	117.122 kips	<i>Available bolt moment strength (no prying)</i>
ϕF_{pl}	31.662 kips	<i>Available end plate flexural strength</i>
ϕF_{cf}	261.383 kips	<i>Available column flange flexural strength</i>
$\phi F_{pl} \geq 1.1 * \phi F_{np} ?$	Fail	<i>Thin plate</i>
$\phi F_{cf} \geq 1.1 * \phi F_{np} ?$	Ok	<i>Thick flange</i>

This check is covered in the AISC Design Guide #4 "Extended End-Plate Moment Connections", 2nd edition, Copyright 2003 in Section 3.3. We check both the end plate and the column flange for "thick" plate behavior.

F_{np} - The no-prying bolt tension rupture strength, found in the [Bolt Moment Strength](#) check.

F_{pl} - The end plate bending strength, found in the [End Plate Flexural Yielding](#) check.

F_{cf} - The column flange flexural strength, found in the [Column Flexural Yielding](#) check.

For 8 bolt moment connections, if either these checks fail, then the no prying assumption is not valid. Thus, the connection will be said to "fail". IN reality, it may work fine, but the user would have to demonstrate how to manually consider prying for the bolt tension checks.

Beam Flange to End Plate Stiffener Buckling

In order to prevent buckling of the stiffener plate, the stiffener plate thickness is checked per eqn (3.16) of the AISC Design Guide #4, 2nd Edition.

Beam Flange to End Plate Stiffener Buckling		0.4460 in	0.5000 in	0.89	PASS
Check condition: $t_{s_{req'd}} \geq 1.79 * h_{st} * (F_{ys} / E)^{0.5}$		<i>(DG-4-2nd (3-16))</i>			
t_s	0.5000 in	<i>Stiffener thickness</i>			
F_{ys}	50.0000 ksi	<i>Minimum yield stress of stiffener</i>			
E	29000.0000 ksi	<i>Modulus of Elasticity</i>			
h_{st}	6.0000 in	<i>Stiffener height</i>			

Beam Web to End Plate Stiffener Buckling

For flush end plate connections, no capacity checks are made on any stiffeners specified between the beam web and end plate.

Note:

- For flush end plate stiffeners, the stiffener is assumed to be half the thickness of the beam flange.
- For flush end plate stiffeners between bolt lines, the stiffeners are assumed to be located at the mid-point between the bolt.
- For flush end plate stiffeners located outside the inner tension bolts, the user may control the stiffener location with the Stiffener Pitch dimension.

End Plate Flexural Yielding

The program uses the procedures and tables from the AISC design guides, to determine an end-plate bending strength, and a no-prying bolt tension rupture strength.

If the plate bending strength exceeds 110% of the bolt rupture strength then thick-plate behavior is confirmed and a code check is given based on the other failure modes of the connection. If the plate bending strength does not exceed 110% of the no prying bolt rupture strength, then the program will calculate bolt prying forces and connection capacity per the procedures given in Design Guide 16.

Note:

- For some connections, the program will not give code checks to end plates which experience thin-plate behavior. If this behavior is reported, increase the thickness of the end plate.

End Plate Flexural Yielding		102.620 kips	31.662 kips	3.24	FAIL
$R_{pl} = \phi F_y t_p^2 Y_p / d_m$, where $\phi = 0.90$				(DG-4.2 nd (3.10))	
$Y_p = 0.5 b_p [h_1 (1/p_{fi} + 1/s) + h_0 (1/p_{fo} - 0.5)] + 2/g [h_1 (p_{fi} + s)]$					
F_y	36.000 ksi				Minimum yield stress of plate
t_p	0.375 in				Thickness of plate
Y_p	107.433 in				Yield-line mechanism parameter
s	2.121 in				Yield line mechanism parameter. $s = 0.5 (b_p/g)^{0.5}$
b_p	6.000 in				Plate width in calculation. $b_p = \min(b_{plate}, b_{fb} + 1")$
p_{fi}	2.060 in				Value p_{fi} in calculation. $p_{fi} = \min(s, p_{fi})$
h_0	17.180 in				Distance from the centerline of the beam compression flange to the centerline of tension bolt row N 0
h_1	13.180 in				Distance from the centerline of the beam compression flange to the centerline of tension bolt row N 1
p_{fi}	2.060 in				Column bolts flange pitch (inner)
p_{fo}	1.500 in				Column bolts flange pitch (outer)
g	3.000 in				Beam bolts horizontal gage
b_{plate}	6.000 in				Plate width
b_{fb}	5.530 in				Beam flange width
d_m	15.460 in				Moment arm between the flange forces
ϕR_{pl}	31.662 kips				End plate bending strength
d_m	15.460 in				Moment arm between the flange forces
R_{req}	102.620 kips				Required Flange Force (worst) in bolts due to moment

End Plate Shear Yielding

The extended portion of the end-plate is checked against shear yielding due to out-of-plane shear (the flange force of the beam). See Eqn 3.12.

End Plate Shear Yielding	52.620 kips	97.200 kips	0.54	PASS
$R_n = 2 * 0.6 * F_y * A_g$		$\phi = 1.00$ (J4-3)		
F_y	36.000 ksi	<i>Minimum yield stress of plate</i>		
A_g	2.250 in ²	<i>Gross area of the end plate</i>		
b_p	6.000 in	<i>Effective plate width</i>		
ϕR_n	97.200 kips	<i>Shear yield strength</i>		
d_m	15.460 in	<i>Moment arm between the flange forces</i>		
R_{req}	52.620 kips	<i>Required Flange Force (tension)</i>		

End Plate Shear Rupture

The extended portion of the end-plate is checked against shear rupture due to out-of-plane shear (the flange force of the beam). See Eqn 3.13.

End Plate Shear Rupture	52.620 kips	83.194 kips	0.63	PASS
$R_n = 2 * 0.6 * F_u * A_n$		$\phi = 0.75$ (J4-4)		
F_u	58.000 ksi	<i>Minimum tensile stress of plate</i>		
A_n	1.594 in ²	<i>Net area of the end plate</i>		
b_p	6.000 in	<i>Effective plate width</i>		
ϕR_n	83.194 kips	<i>Shear rupture strength</i>		
d_m	15.460 in	<i>Moment arm between the flange forces</i>		
R_{req}	52.620 kips	<i>Required Flange Force (tension)</i>		

Eight Bolt Unstiffened End Plate

This bolt configuration cannot be found in either AISC design guide. However, the yield lines are identical to that shown for the MRE 1/2 configuration shown Design Guide 16. The moment strengths based on the bolts need only be modified by accounting for additional bolts at the top row as shown in the image below.

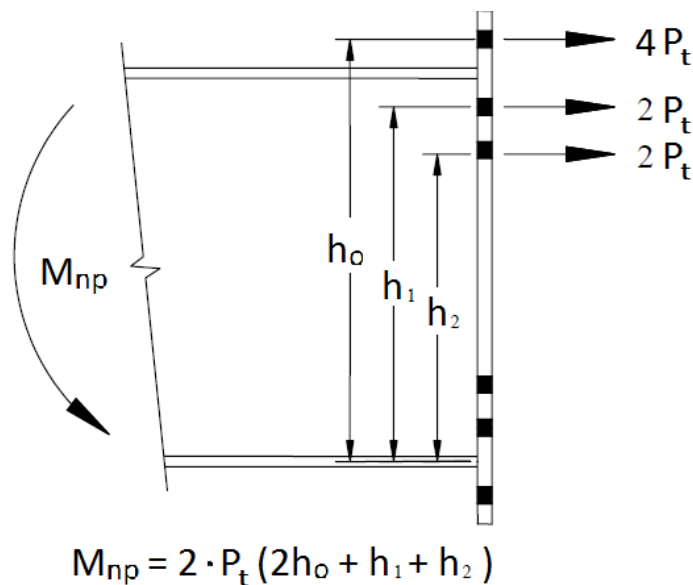

Asymmetric End Plate Connections

End Plate Moment Connections that are flush on both sides or extended on one side and flush on the other may have a different bolt configuration on the tension side of the connection than on the compression side. This changes the yield line patterns when the "compression" side of the connection goes into tension. This will generally happen when there is moment reversal, but can also occur for connections with have a significant axial tension force.

When this occurs, the output reports only report the limit states for the controlling side. To clearly identify when this situation occurs, the program flags the limit state with text that says "(compression side)" as shown in the image below:

Bolt Moment Strength (compression side)	129.1228 kips	56.3975 kips	2.29	FAIL
Verify Bolt Prying Assumption (compression side)				PASS
End Plate Flexural Yielding (compression side)	161.4035 kips	90.4556 kips	1.78	FAIL
End Plate Shear Yielding (compression side)	161.4035 kips	135.0000 kips	1.20	FAIL
End Plate Shear Rupture (compression side)	161.4035 kips	102.8320 kips	1.57	FAIL
Column Flexural Yielding (compression side)	129.1228 kips	188.6368 kips	0.68	PASS

Flush End Plate Connections

RISACONNECTION always assumes that Flush End Plate moment connections will always be designed as Type 1 or Fully Restrained moment connections. That means that γ_r value is always applied to the design of the plate. This is done by increasing the demand force or moment associated with the end plate limit states.

Note:

- The γ_r value is not used to increase the demand force on the bolts or on the column web. This is based on the examples given in AISC Design Guide 16 and because those limit states are not expected to create excess non-linear rotation that would limit the rigidity of the connection.
- The γ_r is used to increase the required strength for column flange yielding. The use for this limit state is a matter of engineering judgment, but is applied in RISACONNECTION because it is felt that excessive column flange bending would result in a similar type of non-linear rotation as end plate yielding.
- The end plate stiffeners are not designed in a Flush End Moment Plate Connection. Their presence only effects which yield line parameter is used for design per the AISC Design Guide 16.

Axial Force in Moment Connections

When an axial force is added to a moment connection, it is assumed that this axial force is carried entirely by the flanges (Please see [Required Flange Force](#)). Therefore, the axial force will not affect the shear checks for the moment connection.

Note:

- There are cases where the axial force will actually REDUCE the design checks on a moment connection. This can happen for flange force failure modes that are not valid for both tension and compression. Example: Flange Local Bending (which is valid only for the tension flange) combined with a compressive axial force in the beam, or Web Buckling (which is valid only for the compression flange).

Moment Connections with Column Stiffeners

If the moment connection includes transverse column stiffeners and / or web doubler plates then additional design checks will be performed on these elements. Refer to the [Stiffener Checks for Moment Connections](#) topic for more information.

Moment Connections into a Column Web (Weak Axis)

RISACONNECTION allows you to model both **Direct Weld**, **Flange Plate Moment** and **Flange Plate Cap Plate Moment** connections into the web of a wide flange column.

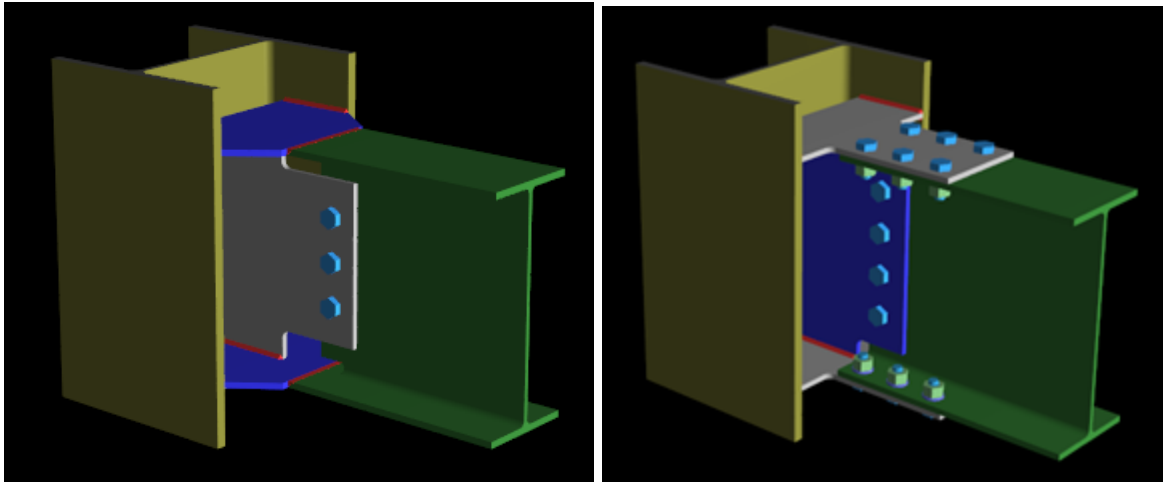

When you select this orientation, the program will automatically include Flange Plate stiffeners that connect to the beam flanges and the inside column flanges. The Flange Plates are assumed to always be welded to the inside flanges of the column. In the case of a cap plate, the cap plate may be welded to both the inside and outside flanges of the column. You may select a Full Width, Tapered, or Coped end that connects to the beam. The flange forces are then resisted by the [flange plate weld strength](#) at the column.

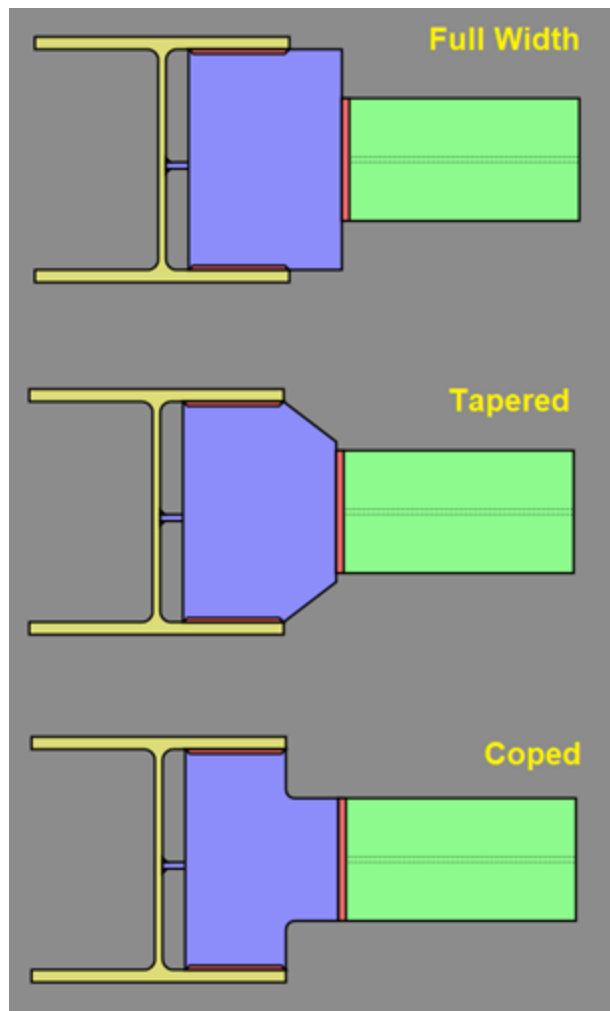
**Note:**

- Beam to column web connections are not available for seismic moment connections or Canadian (CSA) design codes.

Flange Plate Compression Unbraced Length

RISACONNECTION considers the full unbraced length of the compression flange in the Flange Plate Compression check. This is measured from the far edge of the weld access hole on the beam to the weld at the column flange.

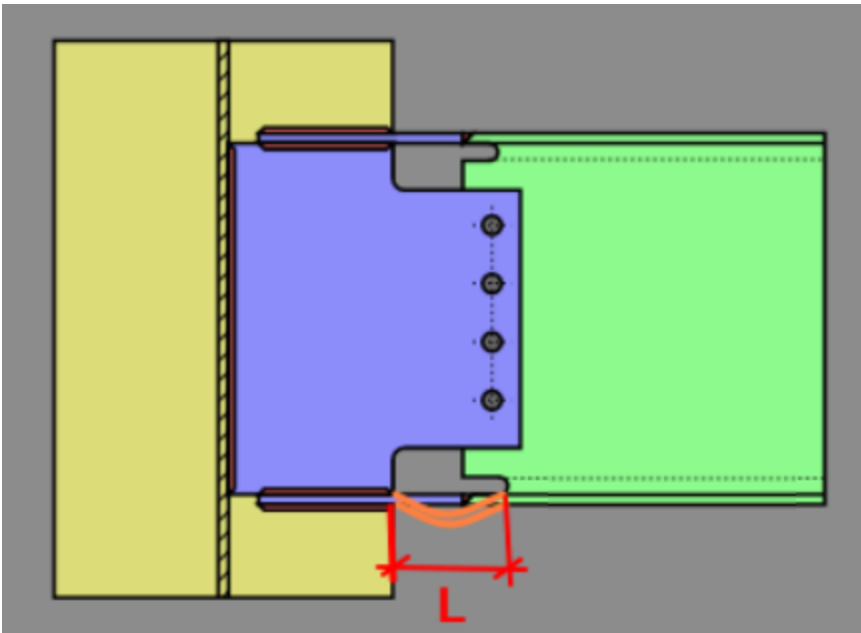

Cap Plate Stiffener Compression Unbraced Length

RISAConnection considers the unbraced length of the cap plate in the Cap Plate Stiffener Compression check to be the clear distance between column flanges.

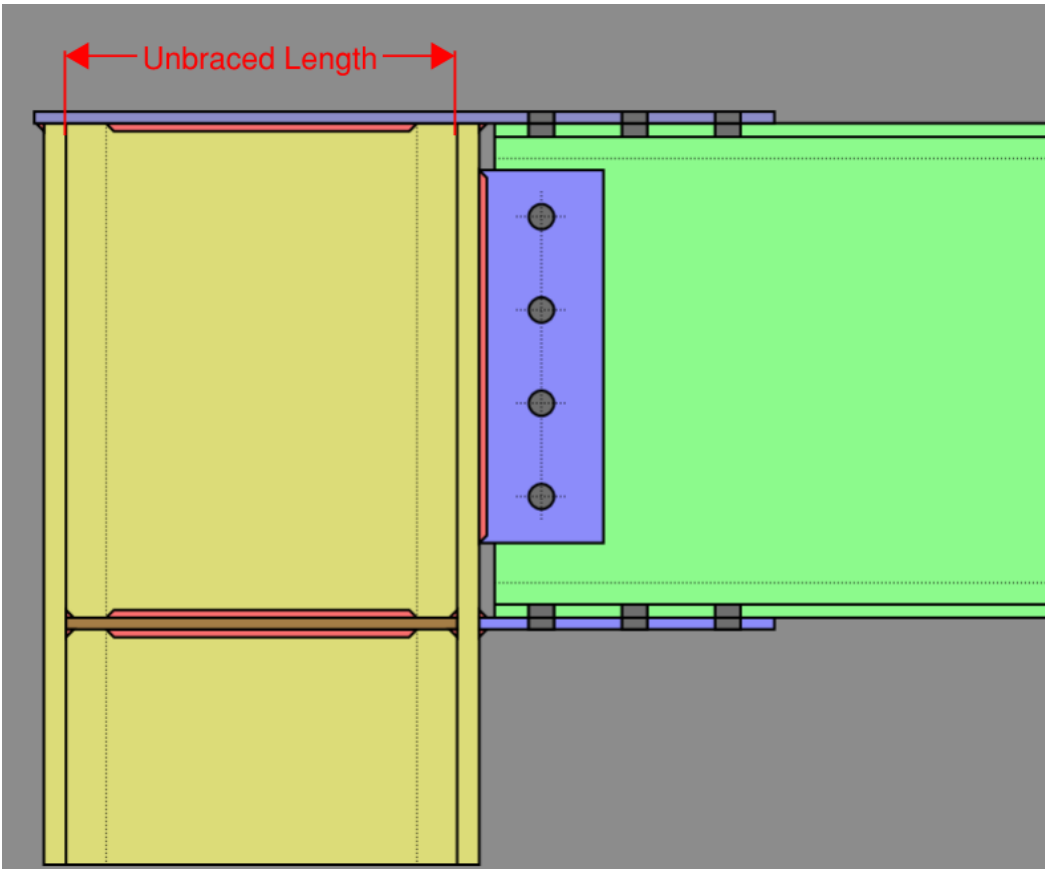

Flange Plate with Cap Plate General Assumptions

The cap plate acts as both a flange plate connected to the top of the beam flange and a transverse stiffener that is connected to the top of the column. The design force used for the cap plate is the beam flange force generated by the moment within the beam. The force developed within the top beam flange is transferred directly into the column through welds at the top of the column. Here are some general assumptions used by RISACONNECTION.

- The cap plate and flange plate will be the same length along the beam
- The flange force in the flange plate and cap plate are always assumed to be equal despite differences in the cap plate thickness and lower flange plate thickness (i.e. having different stiffnesses)
- Column capacity is not considered in the determination of an unbalanced flange force for the cap plate. In other words, the cap plate will always be conservatively designed using the full flange force.
- HSS column checks are only performed at the lower flange plate and not at the top cap plate.
- Welds
 - Weld lengths along a wide flange column web can not be adjusted
 - Weld lengths along wide flange are dictated by the cap plate width and can not be adjusted independently
 - Weld lengths will always be the full length and width for HSS columns
- Seismic Detailing is not available for Flange Plate Moment Column Cap Plate

Continuous Beam over Column Moment Connection

Guidance from the AISC Design Guide 24 is used for the connection checks for the continuous beam over column connection. The connection can support axial load onto the column (from the beam), strong axis bending moment (bending perpendicular to the beam's length), and shear forces in either direction. Weak axis bending moment (bending parallel to the beam's length) is not supported. Additional guidance from AISC Design Guide 4 and 16 are used when Design Guide 24 does not provide sufficient information.

Due to limited guidance for newer AISC codes from Design Guide 24; HSS column wall local checks (yielding and crippling) are completed using more conservative AISC equations. For AISC 15th edition, the yielding check is calculated per AISC J10-3 and the crippling check is calculated per AISC J10-5a.

Stiffener Checks for Moment Connections

These checks relate specifically to the design of column web doubler plates or transverse stiffeners for the column flange (also known as continuity plates). The primary reference for the design of these stiffeners is AISC Design Guide 13. However, the recommendations of this design guide are based on the LRFD 2nd edition design code. Therefore, many of the recommendations in DG-13 have been updated to reflect new or revised provisions in newer AISC 13th or 14th edition specifications. For this reason, RISACONNECTION will generally reference the relevant sections of the 13th or 14th edition codes rather than directly referencing DG-13.

Transverse Stiffeners

The compression force that is required to be resisted by the transverse stiffeners is equal to the flange force transferred from the moment connection minus the capacity of the column flange or web to resist it. The highest demand force will be used based on the checks of flange bending, web yielding, web crippling, and web buckling.

Geometry Restrictions for Transverse Stiffeners

Sections 4.3.2 and 4.3.3 of Design Guide 13 gives a minimum thickness for stiffeners based on section K1.9 of the LRFD 2nd edition. This has been updated to reflect the newer provisions of J10.8.

Geometry Restrictions For Trans. Stiffener			PASS
Check Min Thickness	Pass	<i>Condition: $t_{s_{min}} \geq \max(t_f/2, b_s/16)$ (J10.8)</i>	
t_f	0.43 in	<i>Thickness of beam flange</i>	
b_s	7.03 in	<i>Stiffener width</i>	
t_s	0.50 in	<i>Stiffener thickness</i>	
$t_{s_{min}}$	0.44 in	<i>Min stiffener thickness</i>	
Check Min Depth	Pass	<i>Condition: $d_{s_{min}} \geq (d_c - 2 * t_{cf}) / 2$ (J10.8)</i>	
d_c	14.00 in	<i>Column depth</i>	
t_{cf}	0.71 in	<i>Column flange thickness</i>	
d_s	12.58 in	<i>Stiffener depth</i>	
$d_{s_{min}}$	6.29 in	<i>Min stiffener depth</i>	

Yield and Shear for Transverse Stiffeners

The transfer stiffeners are checked versus the demand forces. It is expected that the stiffeners will receive the force from the column flange and then be required to transmit that force as a shear force into the column web.

Trans. Stiffener Yield at Column Flange		72.38 kips	258.30 kips	0.28	PASS
$R_n = 2 * F_{yst} * A_{st}$			$\phi = 0.9$	(J4-1)	
t_s	0.50 in	<i>Stiffener thickness</i>			
b_s	7.03 in	<i>Stiffener width</i>			
clip	1.29 in	<i>Stiffener corner clip dimension</i>			
F_{yst}	50.00 ksi	<i>Minimum yield stress of Stiffener</i>			
A_{st}	2.87 in ²	<i>Cross-sectional area = $(b_s - clip) * t_s$</i>			
ϕR_n	258.30 kips	<i>Available transverse stiffener strength</i>			
R_{req}	72.38 kips	<i>Required transverse stiffener strength</i>			

Trans. Stiffener Shear at Column Web	72.38 kips	300.00 kips	0.24	PASS
$R_n = 2 * 0.6 * F_{yst} * A_{gv}$		$\phi = 1.0$	(J4-3)	
t_s	0.50 in	Stiffener thickness		
d_p	12.58 in	Stiffener depth		
clip	1.29 in	Stiffener corner clip dimension		
F_{yst}	50.00 ksi	Minimum yield stress of Stiffener		
A_{gv}	5.00 in ²	Cross-sectional area = $(d_p - 2 * clip) * t_s$		
ϕR_n	300.00 kips	Available transverse stiffener strength		
R_{req}	72.38 kips	Required transverse stiffener strength		

Misc. Compression Checks

These checks are not discussed in Design Guide 13. However, AISC specification J10.8 and J4.4 have additional requirements for stiffeners that experience compression.

Note:

- For the r value calculation, RISACONNECTION is conservatively ignoring the presence of the column web. Rather than including the $25t_w$ web strip discussed in J10.8.

Trans. Stiffener Compression	49.23 kips	111.17 kips	0.44	PASS
$R_n = 2 * F_{cr} * A_{st}$		$\phi = 0.9$	(E3-1)	
t_s	0.38 in	Stiffener thickness		
K	0.75	Effective length factor		
L	12.58 in	Unbraced length		
r	0.11 in	Radius of gyration = $t_s / (12)^{0.5}$		
KL/r	87.16	Plate slenderness		
F_y	50.00 ksi	Minimum yield stress of material		
A_{st}	2.15 in ²	Gross area subject to compression		
E	29000.00 ksi	Modulus of elasticity		
F_e	37.68 ksi	Elastic buckling stress (E3-4)		
F_{cr}	28.69 ksi	Critical stress (E3-2)		
ϕR_n	111.17 kips	Compressive strength		

Stiffener Weld Calculations

Refer to the [Weld Calculations](#) topic for more information about how weld strength and limitations are calculated for transverse stiffeners.

Doubler Plates

The shear force that is required to be resisted by the web doubler plate(s) is based on the excess shear force beyond the panel zone capacity itself.

Note:

- RISACONNECTION only considers one moment connection per calculation. Therefore, the program does NOT account for the situation where a moment connection on the opposite flange of the column may add

contributed additional shear force into the columns panel zone.

Doubler Geometry Limitations

To avoid encroachment of the column fillet, the minimum thickness of the doubler plate is determined from equation 4.4-4 of Design Guide 13.

Doubler Geometry Limitation

PASS

Check Fillet Encroachment	Pass	Condition: $t_p \geq k - t_f$ (DG-13 (4.4-4))
t_p	0.6250 in	Doubler plate thickness
k	1.2500 in	Distance from outer face of the flange to the web toe of the fillet
t_f	0.6600 in	Column flange thickness

Per recommendations of the AISC design guide 13 on column stiffening (see figure 4-3), the doubler plate will extend above and below the beam flange (or flange plate) a distance of 2.5k for directly welded connections and 3k+ t_p for end plate moment connections.

Note:

- RISACONNECTION does NOT currently account for the "Riding the Fillet" allowable encroachment per AISC 13th edition's Figure 10-3.

Doubler Shear Calculations

Equation 4.4-5 of Design Guide 13 refers to a minimum thickness to prevent shear buckling of the doubler plate. However, those code provisions have been updated since the release of the design guide. Therefore, RISACONNECTION uses instead the updated provisions of section G2-2(a).

Doubler Shear Buckling

PASS

Check condition : $h / t_p \leq 2.24 * (E / F_y)^{0.5}$		(G2-2)
t_p	0.6250 in	Doubler Plate thickness
d	13.9000 in	Depth of the column
K_{des}	1.2500 in	K_{des} of the column
h	11.4000 in	Clear distance between flanges = $d - 2 * K_{des}$
E	29000.0000 ksi	Modulus of elasticity
F_y	50.0000 ksi	Minimum Yield Stress

Note:

- RISACONNECTION does NOT consider the alternative shear buckling provisions of G2.2(b) or G3.

Doubler Plate Shear Yield		33.2560 kips	260.6250 kips	0.13	PASS
$R_n = N_{\text{doubler}} * 0.6 * F_y * A_w * C_v$			$\phi = 1.0$	(G2-1)	
N_{doubler}	1		<i>Count of doublers</i>		
t_p	0.6250 in		<i>Doubler plate thickness</i>		
F_y	50.0000 ksi		<i>Minimum yield stress of doubler plate</i>		
d_{col}	13.9000 in		<i>Column depth</i>		
A_w	8.6875 in ²		<i>Area of web = $t_p * d_{\text{col}}$ DG-13 (4.4-1)</i>		
C_v	1.0000		<i>Shear coefficient</i>		
ϕR_n	260.6250 kips		<i>Plate shear yield strength</i>		
R_{req}	33.2560 kips		<i>Required doubler plate shear force</i>		

Doubler Plate Weld Calculations

Refer to the [Weld Calculations](#) topic for more information about how weld strength and limitations are calculated for doubler plates.

Seismic Moment Connections

Design for seismic moment connection detailing is done per the *AISC Seismic Design Manual, 3rd Edition (2016)* & *2nd Edition (2010)* contains two documents: the *AISC 341-16/10 Seismic Provisions for Structural Steel Buildings* and the *AISC 358-16/10 Prequalified Connections for Special and Intermediate Steel Moment Frames for Seismic Applications*. These documents contain common design standards for seismic systems, including seismic connection design criteria.

The following seismic moment connections are available:

- Moment Frame Systems:
 - Column/Beam Direct Weld Moment Connection
 - [Reduced Beam Section Moment Connection](#) (OMF, IMF, SMF)
 - [Welded Un-reinforced Flange-Welded Web Moment Connection](#) (OMF, IMF, SMF)
 - Column/Beam Extended End Plate Moment Connection
 - [Bolted Un-stiffened Extended End Plate Moment Connection](#) (OMF, IMF, SMF)
 - [Bolted Stiffened Extended End Plate Moment Connection](#) (OMF, IMF, SMF)
 - Column/Beam Flange Plate Moment Connection
 - [Bolted Flange Plate Moment Connection](#) (OMF, IMF, SMF)
- Braced Frame Systems:
 - See the [Seismic Vertical Brace Connections](#) topic for information on which seismic braced connections are available.

Note:

- Unless otherwise specified, all code references below are to AISC 341-16 and AISC 358-16.
- Seismic moment connection design in RISACONNECTION is limited to the current edition of the US design code. No results will be given if you select any other design code.
- Per section 1.3 of the AISC 358-16/10, the all pre-qualified IMF and SMF connection types must be designed according to the Load and Resistance Factor (LRFD) provisions. Therefore, only the OMF, OCBF, and SCBF connection types are allowed to be designed per ASD provisions.

How to Create a Seismic Moment Connection

Starting from Scratch in the Stand-Alone Version

If you are using RISACONNECTION as a stand-alone program, then you can define your seismic moment connection as follows:

1. Start a new model and select your Column/Beam Moment connection type. Applicable connection types are:
 - a. Column/Beam Direct Weld Moment Connection
 - b. Column/Beam Extended End Plate Moment Connection
 - c. Column/Beam Flange Plate Moment Connection

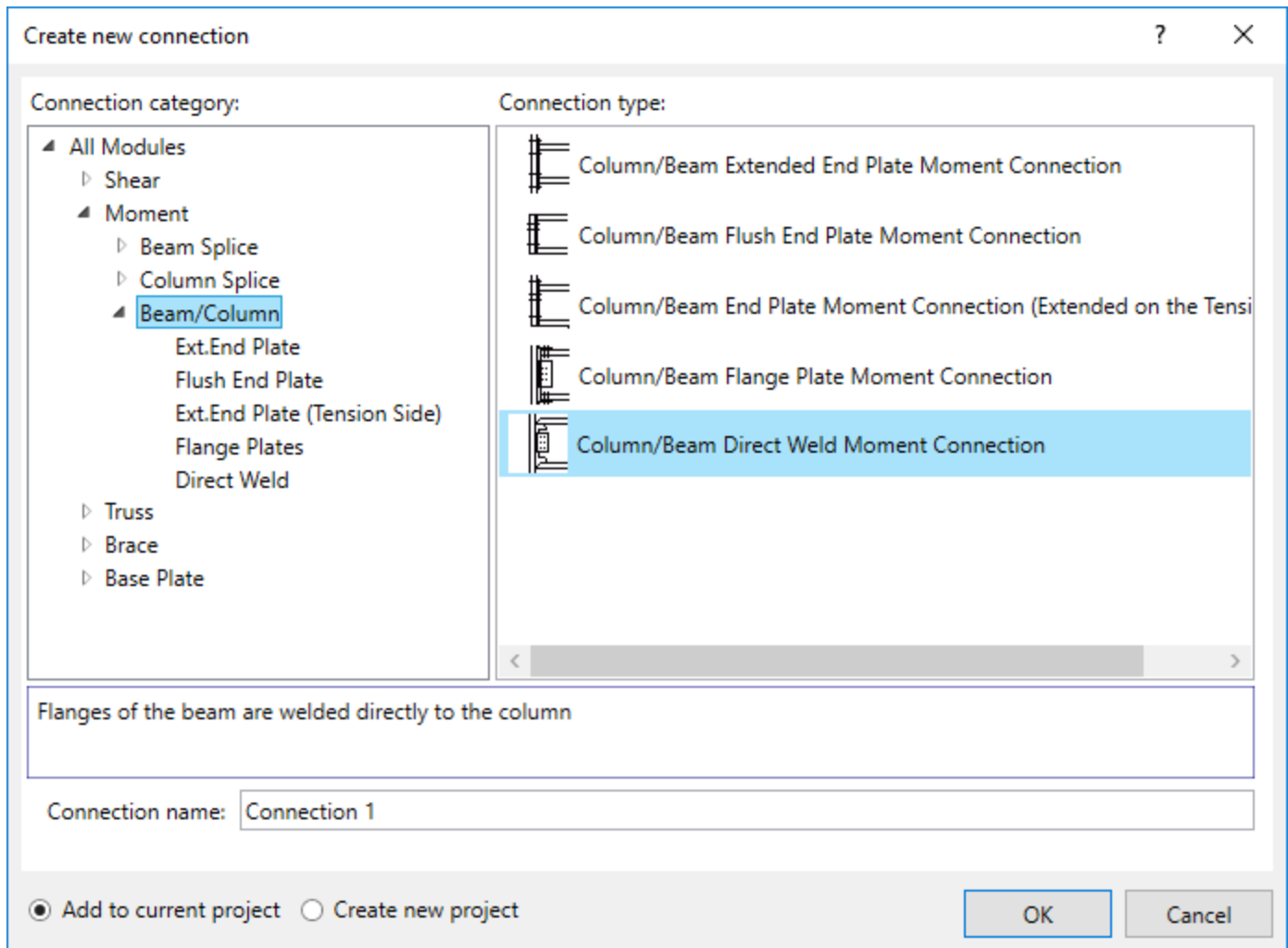

2. Select your **Seismic System**.

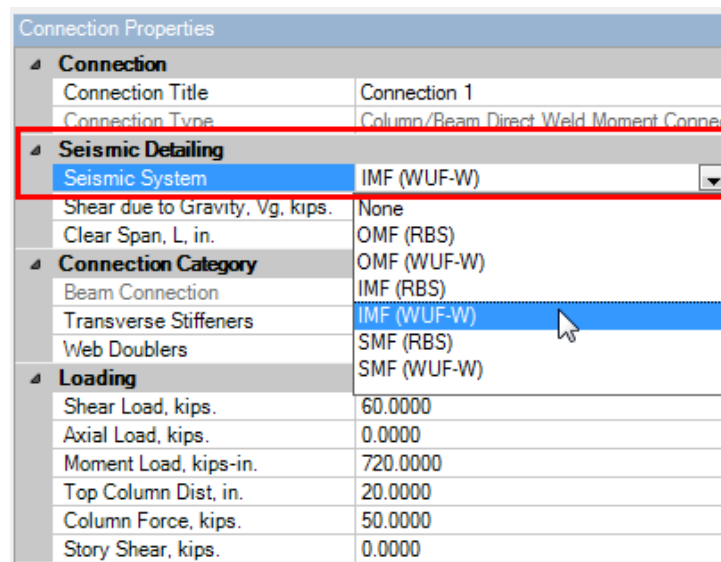

3. Enter the appropriate [Seismic Moment Connection Input Values](#).

Connection Properties	
Connection	
Connection Title	Connection 1
Connection Type	Column/Beam Direct Weld Moment Connec
Seismic Detailing	
Seismic System	IMF (WUF-W)
Shear due to Gravity, Vg, kips.	35.5000
Clear Span, L, in.	240.0000
Connection Category	
Beam Connection	Welded

Importing a Connection from a RISAFloor or RISA-3D Model

If you are using the integration between RISA-3D and RISACONNECTION to create your model, then you can define your seismic connection as follows:

RISA-3D:

1. If you are using RISA-3D on its own, then you must apply *both* a "Column/Beam Seismic Moment" **Connection Rule** and a **Seismic Design Rule** to the member.

3D Connection Rules					
Hot Rolled					
	Label	Conn Type	Type	Beam Conn	Col/Girder Conn
1	Seismic Moment	Moment	Column/Beam Seismic Moment	N/A	N/A
2	Seismic Diag. Brace	Brace	Diagonal Brace Seismic	N/A	N/A
3	Seismic Chevron	Brace	Chevron Brace Seismic	N/A	N/A

3D Frame / HR Column Seismic Design Rule			
Column Beam Brace			
	Label	Frame Ductility	Overstrength Req'd
1	OCBF	Minimal	<input checked="" type="checkbox"/>
2	SCBF	High	<input checked="" type="checkbox"/>
3	OMF	Minimal	<input checked="" type="checkbox"/>
4	IMF	Moderate	<input checked="" type="checkbox"/>
5	SMF-RBS	High	<input checked="" type="checkbox"/>

2. Make sure to solve in RISA-3D for your *seismic detailing results*. If you do not have seismic detailing results in RISA-3D, then the information cannot be exported to RISACONNECTION. For more information about seismic detailing results, see the RISA-3D Help file topic "**Seismic Detailing**".
3. When exported into RISACONNECTION, the program will determine the **Connection Type**, **Seismic System**, and seismic input values based on the applied Seismic Design Rule and the RISA-3D solution results. Once in RISACONNECTION, these cannot be changed.

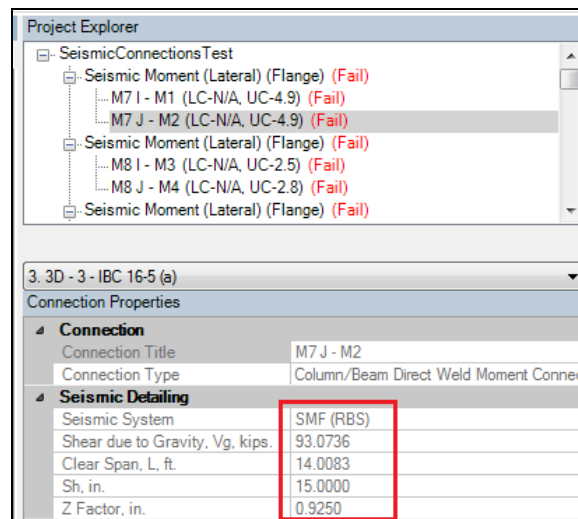

RISAFloor:

1. If you are using RISAFloor, you can apply the **"Seismic Moment" Connection Rule** within RISAFloor or in RISA-3D.
 - a. You may only apply the **"Seismic Moment" Connection Rule** to Lateral members.
2. Use the **Director** tool to take the model into RISA-3D in order to apply the **Seismic Design Rule**. Solve your lateral load combinations in RISA-3D in order to get your *Seismic Detailing* results.
 - a. If you have not done this, the connection will not export to RISAConnection.
3. When exported into RISAConnection, the program will determine the **Connection Type, Seismic System**, and seismic input values based on the applied **Seismic Design Rule** and the RISA-3D solution results. Once in RISAConnection, these cannot be changed.

Determining the Seismic System

The integration between programs uses the following "translation" to determine the **Seismic System** for moment connections:

Connection Rule	RISA-3D Input		RISAConnection Export	
	Seismic Design Rule		Connection Type	Seismic System
	Frame Ductility	Moment Connection		
Column/Beam Seismic Moment	Minimal	BFP	Flange Plate Moment	OMF (BFP)
	Moderate	BFP	Flange Plate Moment	IMF (BFP)
	High	BFP	Flange Plate Moment	SMF (BFP)
	Minimal	RBS	Direct Weld Moment	OMF (RBS)
	Moderate	RBS	Direct Weld Moment	IMF (RBS)
	High	RBS	Direct Weld Moment	SMF (RBS)
	Minimal	BUEEP	End Plate Moment (Unstiffened)	OMF (BEEP)
	Moderate	BUEEP	End Plate Moment (Unstiffened)	IMF (BEEP)
	High	BUEEP	End Plate Moment (Unstiffened)	SMF (BEEP)
	Minimal	BSEEP	End Plate Moment (Stiffened)	OMF (BEEP)
	Moderate	BSEEP	End Plate Moment (Stiffened)	IMF (BEEP)
	High	BSEEP	End Plate Moment (Stiffened)	SMF (BEEP)
	Minimal	WUF-W	Direct Weld Moment	OMF (WUF-W)
	Moderate	WUF-W	Direct Weld Moment	IMF (WUF-W)
	High	WUF-W	Direct Weld Moment	SMF (WUF-W)

Seismic Moment Connection Input Values

The following seismic input values are available for moment connections:

- **Shear due to Gravity, V_g** - Beam shear due to gravity loads, $V_{gravity}$. This is used to determine the required shear strength, V_h , of the beam and beam web-to-column connection.
- **Clear Span, L** - Clear length of the beam between supporting column flanges.
- **Sh** - Plastic Hinge Location, distance from face of column flange. (Only for RBS connections imported from RISA-3D, otherwise this value is calculated based on the [RBS dimensions](#).)
- **Z Factor** - Ratio of the reduced plastic section modulus of the RBS to the full plastic section modulus of the beam. This value comes from RISA-3D, so it is only available for RBS connections that were imported from RISA-3D.
- **R*Mu** - Required moment for OMF connections. See [OMF Required Strength](#) for more information. (Only for OMF connections.)
- **R*Vu** - Required shear for OMF connections. See [OMF Required Strength](#) for more information. (Only for OMF connections.)

Seismic Moment Connection Limitations

Below is a list of limitations regarding the seismic design:

- Seismic design is not supported under the Canadian design code.
- Seismic design is not supported under the *AISC 341-05 (1st edition) Seismic Design Manual*.
- IMF and SMF connection types must use the LRFD design method.
- OMF, OCBF, & SCBF connection types can use either ASD or LRFD design.
- Seismic Design will not apply to splice connections at this time.
- RISACONNECTION will not design stability bracing, however these requirements are addressed in RISA-3D.
- Code provisions for steel backing on welds are not checked at this time.
- Strong Column-Weak Beam checks can only consider a single story column at this time.

Reduced Beam Section (RBS) Moment Connection

A Reduced Beam Section moment connection may be defined in RISACONNECTION as the "**RBS**" **Seismic System** within the **Column/Beam Direct Weld Moment Connection**. Depending on the ductility of your system, you may assign the RBS as an OMF, IMF, or SMF. The design of this type of connection is done per *AISC 341-16* and *AISC 358-16, chapter 5*. Please see the [Seismic Moment Connection Checks](#) section for more information.

When you use this connection type, the following changes to geometry and assembly apply:

Web Weld Entry

In addition to the existing welding/bolting requirements of the moment connections, the **Column/Beam Direct Weld Moment Connection** includes the "**Web Weld**". This weld is between the beam web and the column flange. It is required per *AISC 358-16 chapter 5, section 5.6 (2) (a)* (for RBS) and per *AISC 358-16 chapter 7, section 8.6 (5)* (for WUF-W). This weld must be a CJP with an electrode type of either E70, E80, or E90.

Components	
Column Section	W14X90
Beam Section	W16X36
Plate Section	P0.38x3.50x12.00
Column Weld	E70
Beam Bolts	3/4" A325-N
Moment Weld	E70
Type	CJP
Web Weld	E70
Type	CJP

Weld Access Holes

RISACONNECTION will automatically modify the geometry of the RBS and WUF-W seismic connections to include the Weld Access Hole Requirements of the *AISC 358-16*. This manual refers to the *AWS D1.8/D1.8M 2009 section 6.10.1.2*. RISACONNECTION uses the limits of this code to determine the geometry of the Weld Access Holes:

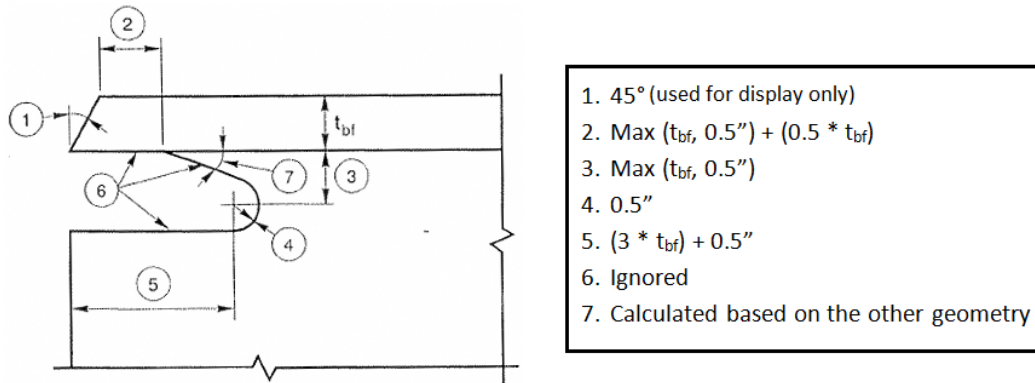

AWS D1.8/D1.8M Figure 6.2

Note:

- Currently these are not editable.

RBS Dimensions

RISACONNECTION will apply default dimensions to the reduced beam section. But you may edit these at any time in the **Assembly** section of the **Connection Properties**.

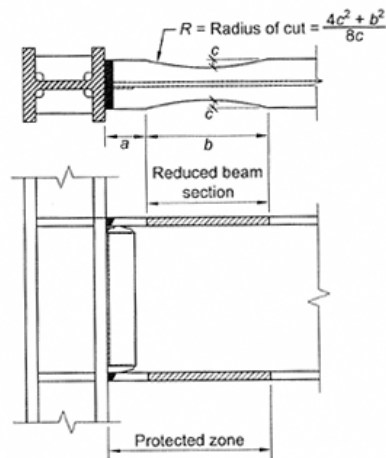

Fig. 5.1. Reduced beam section connection.

Assembly	
Column/Beam Clearance, in.	0.0000
Plate Vertical Position, in.	1.4300
Beam Bolts Edge Distance Dimensions	
RBS Connection Dimensions	
Horiz Dist from Col to RBS (a), in.	4.3688
Length of RBS (b), in.	11.9250
Depth at Center of RBS Cut (c), in.	1.2233

RISA-3D Integrated Models

When a seismic moment RBS connection is imported from RISA-3D, the a, b, and c dimensions are predetermined from the RISA-3D Seismic Design Rules data. In the RISA-3D Seismic Design rule, you are required to input a Z Factor (ratio of reduced section Z to full section Z) and a Hinge Location (distance from face of column flange to the center of the reduced section).

Seismic Design Rule spreadsheet from RISA-3D:

Column	Beam	Brace			
	Label	Moment Connection	Overstrength Req'd	Z Factor	Hinge Location[in]
1	OCBF	Other/None	<input type="checkbox"/>		
2	SCBF	Other/None	<input checked="" type="checkbox"/>		
3	OMF	BUEEP	<input type="checkbox"/>		12
4	IMF	BFP	<input type="checkbox"/>		12
5	SMF-RBS	RBS	<input type="checkbox"/>	.685	14.625
6	SMF-Kaiser	KBB-B	<input type="checkbox"/>		12

In order to assure that the RISA-3D results are consistent with the RISACONNECTION results, RISACONNECTION will then automatically calculate these dimensions.

- The a and b values are dependent on the Hinge Location: $a + 0.5*b = \text{Hinge Location}$. If you change one of these values, the other will also update based on this equation.
- The c value is back-calculated from *AISC 358-16* equation 5.8-4 using the Z Factor. This value cannot be edited.

Assembly	
Column/Beam Clearance, in.	0.000
Plate Vertical Position, in.	1.780
Beam Bolts Edge Distance Dimensions	
RBS Connection Dimensions	
Horiz Dist from Col to RBS (a), in.	4.369
Length of RBS (b), in.	20.513
Depth at Center of RBS Cut (c), in.	2.304

RBS Limitations

- The beam connection must be bolted.
- The shear plate depth is required to extend the full distance between the weld access holes (per *AISC 358-16* section 5.6 (2) (a)).

Welded Un-reinforced Flange Welded Web (WUF-W) Moment Connection

A Welded Unreinforced Flange- Welded Web moment connection may be defined in RISACONNECTION as the "**WUF-W**" Seismic System within the **Column/Beam Direct Weld Moment Connection**. Depending on the ductility of your system, you may assign the WUF-W as an OMF, IMF, or SMF. The design of this type of connection is done per *AISC 341-16* and *AISC 358-16, chapter 8*. Please see the [Seismic Moment Connection Checks](#) section for more information.

When you use this connection type, the following changes to geometry and assembly apply:

Web Weld Entry

In addition to the existing welding/bolting requirements of the moment connections, the **Column/Beam Direct Weld Moment Connection** includes the "**Web Weld**". See the [discussion above](#) for more information.

Weld Access Holes

RISACONNECTION will automatically modify the geometry of the RBS and WUF-W seismic connections to include the Weld Access Hole Requirements of the *AISC 358-16*. See the [discussion above](#) for more information.

WUF-W Dimensions

RISACONNECTION will apply default dimensions to the WUF-W shear plate. But you may edit these at any time in the **Assembly** section of the **Connection Properties**.

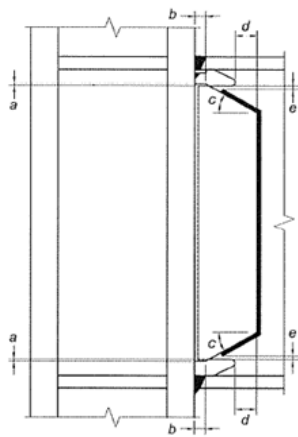

Fig. 8.3. Details at top and bottom of single-plate shear connection.

Assembly	
Column/Beam Clearance, in.	0.0000
Plate Vertical Position, in.	1.1800
WUF-W Connection Dimensions	
Vert Access Hole to Plate Dist (a), in.	0.2500
Plate Distance to Taper Start (b), in.	1.0000
Plate Taper Angle (c), degrees	30.0000
Horz Access Hole to Plate Dist (d), in.	2.0000
Vert Plate Weld to Hole Dist (e), in.	0.5000

WUF-W Limitations

- The beam connection must be welded.

Bolted Stiffened/Un-stiffened Extended End Plate (BEEP) Moment Connection

A Bolted Unstiffened or Stiffened Extended End-Plate moment connection may be defined in RISACONNECTION as the "BEEP" **Seismic System** within the **Column/Beam Extended End Plate Moment Connection**. The end plate can be stiffened or unstiffened depending on if you have applied a stiffener plate in the [Connection Category](#) input of Connection Properties (this is required for 8 bolt layouts).

Depending on the ductility of your system, you may assign the BEEP as an OMF, IMF, or SMF.

The design of this type of connection is done per *AISC 341-16* and *AISC 358-16, chapter 6*. Please see the [Seismic Moment Connection Checks](#) section for more information.

Bolted Flange Plate (BFP) Moment Connection

A Bolted Flange Plate moment connection may be defined in RISACONNECTION as the "BFP" **Seismic System** within the **Column/Beam Flange Plate Moment Connection**. Depending on the ductility of your system, you may assign the BFP as an OMF, IMF, or SMF.

The design of this type of connection is done per *AISC 341-16* and *AISC 358-16, chapter 7*. Please see the [Seismic Moment Connection Checks](#) section for more information.

Ordinary Moment Frame (OMF) Connections

The *AISC 358-16* is specifically for the design of seismic IMF & SMF connections. However, you are allowed to define your connection as an Ordinary Moment Frame (OMF) using any of the *AISC 358-16* pre-qualified connection types. In this case, many of the checks will be for reference only as they are not specifically required by the design code.

OMF Required Strength

Per *AISC 341-16 section E1.6b*, the *flexural strength* of an OMF shall be the lesser of:

- $1.1 \cdot R_y \cdot M_p$ (LRFD) / $(1.1/1.5) \cdot R_y \cdot M_p$ (ASD)
- $R \cdot M_u$ (For minimally ductile moment frames, the required moment need not exceed $R \cdot M_u$ based on discussion in the *AISC 341 commentary*)

Per *AISC 341-16 section E1.6b*, the required *shear strength* of an OMF is computed using the *AISC 360-16 (15th edition)* load combinations.

When a model is imported from RISA-3D, these values are brought over from the RISA-3D seismic detailing calculations. When a model is created using the stand-alone version of RISACONNECTION, the user is expected to enter these values.

Seismic Moment Connection Checks

The following checks are included with the regular (*AISC 360-16, 15th edition*) checks for seismic moment connections. The seismic checks will always be shown at the bottom of the [results report](#) for seismic moment connections.

If you are using a RISA-3D integrated model, these checks do not depend on the loads from the load combinations. The seismic checks design to a *probable* maximum moment which is independent of the actual applied forces.

Seismic Material and Geometry Limitations -

This check includes material geometry limits from the *AISC 341-16* and from the applicable chapter in the *AISC 358-16*. Specific code section references are presented in the output report.

Seismic Width to Thickness Ratios-

This check includes width to thickness ratio checks per *AISC 341-16, Table D1.1*.

For *OMF* connections, this check is for reference only.

Seismic Moment at Face of Column-

This section calculates the probable maximum moment at the face of the column, M_f and the design flange force, F . This is required by all connection types per the *AISC 358-16*. Specific code section references are presented in the output report.

For *OMF* connections, this check is for reference only. RISACONNECTION will check to see which is the minimum design moment ($R \cdot M_u$ or M_{pr}) and which is the minimum design shear ($R \cdot V_u$ or V_h) and then use that to calculate the design flange force. Based on the *AISC 341-16 commentary*, the required moment of minimally ductile moment frames need not exceed $R \cdot M_u$.

Seismic Parametric Limitations-

This check is only applicable to Extended End Plate Moment Connections (BSEEP, BUEEP). It includes geometry limitation checks based on *AISC 358-16, Table 6.1*.

Seismic Weld Limitations-

This checks the requirements of *AISC 341-16, section A4* and the specific weld requirements of each chapter in the *AISC 358-16*. Specific code section references are presented in the output report.

Seismic Flange Bolt Limitations-

This check is only applicable to Bolted Flange Plate Moment Connections (BFP). It checks the bolt size and spacing requirements of *AISC 358-16 chapter 7*. Specific code section references are presented in the output report.

Seismic Flange Plate Limitations-

This check is only applicable to Bolted Flange Plate Moment Connections (BFP). It checks the beam flange plate thickness and connection limitations of *AISC 358-16 chapter 7*. Specific code section references are presented in the output report.

Seismic Bolt Limitations-

This check is only applicable to Extended End Plate Moment Connections (BSEEP, BUEEP). It checks the bolt material and size requirements of *AISC 358-16 chapter 6*. Specific code section references are presented in the output report.

Seismic Plate / Misc Limitations-

This check is only applicable to Extended End Plate Moment Connections (BSEEP, BUEEP). This checks the end plate width limitation as well as the end plate and the column flange for "thick" plate behavior. The "thick plate" check is covered in the *AISC Design Guide #4 "Extended End-Plate Moment Connections", 2nd edition, Section 3.3*. This is the same as the regular [Verify Bolt Prying Assumption](#) check.

Seismic End Plate Limitations-

This check is only applicable to Extended End Plate Moment Connections (BSEEP, BUEEP). It checks the end plate thickness and width requirements of *AISC 358-16 chapter 6*. Specific code section references are presented in the output report.

Seismic RBS Connection Detail Limitations-

This check is only applicable to Direct Weld - Reduced Beam Section Moment Connections (RBS). It checks the reduced beam section geometry requirements of *AISC 358-16 chapter 5*. Specific code section references are presented in the output report.

Seismic WUF-W Connection Detail Limitations-

This check is only applicable to Direct Weld - Welded Unreinforced Flange-Welded Web Moment Connections (WUF-W). It checks the WUF-W shear plate geometry requirements of *AISC 358-16 chapter 8*. Specific code section references are presented in the output report.

Seismic Column-Beam Moment Ratio-

This section calculates the column-beam moment ratio. This is required for all SMF connection types per *AISC 341-16, section E3.4a*. Specific code section references are presented in the output report. Because RISACONNECTION only has column and loading information for the one column, only a single story height column will be considered in the calculation of M^*pc (projected flexural strength of the column).

For *OMF* and *IMF* connections, this check is for reference only.

Seismic Flexural Strength of Beam-

This check is only applicable to Direct Weld - Reduced Beam Section Moment Connections (RBS). It checks the flexural strength of the beam at the face of the column per *AISC 358-16, equation (5.8-8)*.

Seismic Flange Strength-

This check is only applicable to Bolted Flange Plate Moment Connections (BFP). It checks the beam flange tensile rupture, block shear, and compression buckling per *AISC 358-16 section 7.6*. Specific code section references are presented in the output report.

Seismic Beam Web Checks-

This checks the beam web shear limit states per *AISC 358-16*. Specific code section references are presented in the output report.

Seismic End Plate Shear-

This check is only applicable to Extended End Plate Moment Connections (BSEEP, BUEEP). It checks the end plate shear limit states of *AISC 358-16 chapter 6*. Specific code section references are presented in the output report.

Seismic End Plate Flexural Yielding-

This check is only applicable to Extended End Plate Moment Connections (BSEEP, BUEEP). It checks the end plate design strength per *AISC 358-16, equation (6.8-5)* (*AISC 358-10, equation (6.10-5)*).

Seismic Bolt Strength-

This check is only applicable to Extended End Plate Moment Connections (BSEEP, BUEEP). It checks the bolt shear and bearing limit states of *AISC 358-16 chapter 6*. Specific code section references are presented in the output report.

Seismic Bolt Moment Strength-

This check is only applicable to Extended End Plate Moment Connections (BSEEP, BUEEP). It checks the bolt moment strength against the probable seismic design flange force per *AISC 358-16, equation (6.8-3)* (*AISC 358-10, equation (6.10-3)*).

Seismic Flange Bolt Shear Strength-

This check is only applicable to Bolted Flange Plate Moment Connections (BFP). It checks the flange bolt shear strength per *AISC 358-16, equation (7.6-8)*.

Seismic Beam Web Bolt Checks-

This check is only applicable to Bolted Flange Plate Moment Connections (BFP). It checks the beam web bolt bearing and shear limit states per *AISC 358-16, chapter 7*. Specific code section references are presented in the output report.

Seismic Vert. Plate Checks-

This check is only applicable to Bolted Flange Plate Moment Connections (BFP). It checks the beam web shear plate (vertical plate) shear limit states per *AISC 358-16, chapter 7*. Specific code section references are presented in the output report.

Seismic Column Weld Strength-

This check is only applicable to Direct Weld - Welded Unreinforced Flange-Welded Web Moment Connections (WUF-W). It checks the column weld shear strength per *AISC 358-16, section 8.6 (2)*.

Seismic Column Strength-

This check is only applicable to ordinary moment frames (*OMF*). It checks the column limit states per *AISC 341-16, section E1.6b*.

Seismic Column Web Strength-

This check is only applicable to Extended End Plate Moment Connections (BSEEP, BUEEP). It checks the column web limit states per *AISC 341-16 section E1.6b*.

Seismic Column Flexural Yielding-

This check is only applicable to Extended End Plate Moment Connections (BSEEP, BUEEP). It checks the column flange design strength per *AISC 358-16, equations (6.8-14 & 6.8-15)* (*AISC 358-10, equations (6.10-14 & 6.10-15)*).

Seismic Stiffener Plate Limitations-

This checks the transverse stiffeners (continuity plate) requirements per *AISC 341-16, section E3.6f (2)*. If this check fails, then continuity plates are required.

Seismic Stiffener Strength-

This check is only applicable to Extended End Plate Moment Connections (BSEEP, BUEEP). It is only included when transverse stiffeners (continuity plates) are included in the model. This will check the transverse stiffener strength per *AISC 358-16, section 6.8.2 step 6* (*AISC 358-10, section 6.10.2 step 6*). Specific code section references are presented in the output report.

Seismic Panel Zone Limitations-

This check only applies to special moment frames (*SMF*). It checks the panel zone thickness requirements per *AISC 341-16, section E3.6e (2)*. If this check fails, then web doubler plates are required.

Seismic Panel Zone Shear-

This checks the shear strength of the panel zone per the requirements of the *AISC 358-16*. Specific code section references are presented in the output report. If this check fails, then web doubler plates are required.

For *OMF* connections, this check is per the regular *AISC 360-16 (15th edition) section J10.6*.

For *OMF* and *IMF* connections, this check is for reference only.

Seismic Doubler Plate Strength-

This checks the yield strength and weld strength of the doubler plate against the required doubler plate shear force due to seismic forces. Specific code section references are presented in the output report.

Because Seismic Panel Zone shear is only applicable to **SMF** connections, this check is not applicable to **OMF** or **IMF** connections.

Seismic Moment Connection DXF Output

In addition to the regular DXF output, the seismic moment connections will include:

- Identification of the seismic system
- Identification of the demand critical welds
- Identification of the protected zone (only applicable to IMF & SMF seismic systems)

Vertical Brace Connections

The Vertical Brace Connections are intended for braces in the vertical plane, or as truss connections.

Available Vertical Brace Connection Types:

- [Diagonal Brace](#) with the brace above, below, or both.
- [Chevron Brace](#) with braces above or below.
- [Knee Brace](#) connected to a beam or column.

The following shape types are allowed:

Shape Type	Columns	Beams	Braces
Wide Flange	•	•	†
HSS Tube	•	•	•
HSS Pipe	•	•	•
Single Angle			•
Double Angle			•
Channel			•
WT			•

† Wide Flange braces not available for Knee Brace Connection

Diagonal and Chevron braces can be designed as non-seismic ($R=3$) connection types or as part of an OCBF or SCBF Seismic System. For more information on seismic vertical brace design, see the [Seismic Vertical Brace Connections](#) topic.

Limitations

Below is the list of current limitations for vertical brace design in RISACONNECTION.

Beam Member

- For Chevron Brace connections the beam must be a wide flange, tube, or pipe.
- For Diagonal Brace connections the beam must be a wide flange.
- For Knee Brace connections the beam must be a wide flange, tube, or pipe.
- For Diagonal Brace connections the beam must connect to the face of the column (i.e. no continuous beams allowed).
- The beam must be horizontal (not sloped).
- The beam cannot be skewed with respect to the column or brace.
- The web of the beam is not checked for buckling/crippling due to vertical forces from the gusset(s).
- In Chevron Brace connections the interaction of forces from a chevron above the beam and a chevron below that same beam are ignored. Each Chevron Brace connection is treated independently.

Column Member

- The column must be a wide flange, tube, or pipe.
- The column must be vertical (not sloped).
- The gusset(s) and beam must frame perpendicular to the web or flange of the column (not skewed).
- The web of the column is not checked for buckling/crippling due to the horizontal forces from the gusset(s).
- The web of the column is not checked for knifing or localized bending due to horizontal forces from the gusset(s) framing into the web.

- In Vertical Brace connections the interaction of forces from a diagonal brace on the right side of the column and a diagonal brace on the left side of that same column are ignored. Each Vertical Brace connection is treated independently.

Brace Member

- The brace must form at least a 10 degree angle with the beam axis.
- The brace must form at least a 10 degree angle with the vertical axis.
- The brace must lie in the plane of both the beam and the column.
- Wide Flange braces must be oriented so the web is parallel to the gusset plate.
- Wide Flange braces only support bolted sub-connections at this time.

Canadian Connections

- Unfortunately HSS Tube and Pipe members are not yet available for any vertical brace connections designed with the Canadian design codes: *CSA S16-09* or *CSA S16-14*.

Tapered Gusset Plate

Gusset plates for Vertical Diagonal Braces and Knee Braces can be rectangular or have tapered edges. There are two ways to model a tapered gusset plate: **Cut Back** or **Custom Angle**.

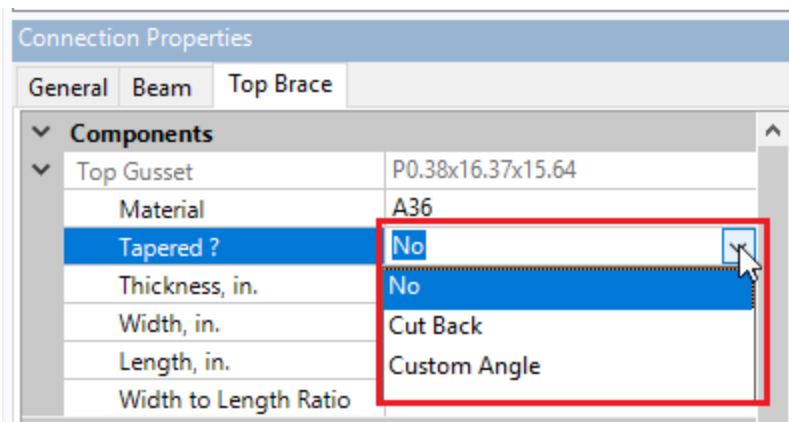

Cut Back

To enter a **Cut Back** taper, enter Cut Length and Cut Width dimensions to "cut back" the original rectangular gusset.

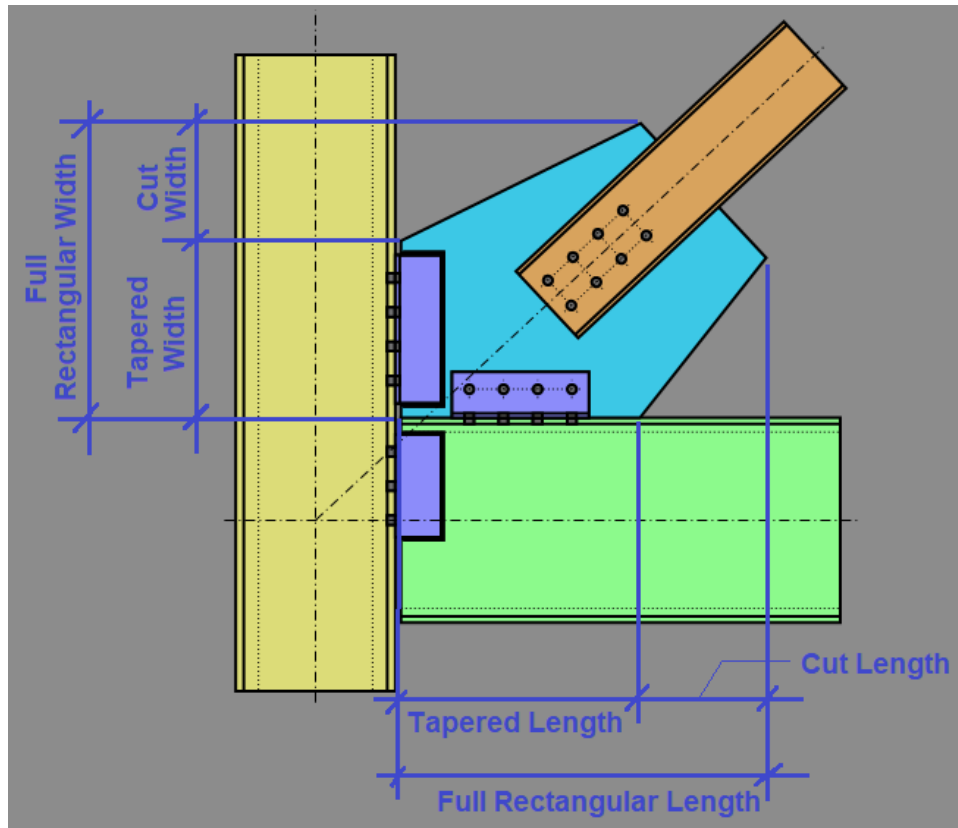

Custom Angle

To enter a **Custom Angle** taper, enter Left and Right Side Cut Angles (from the vertical axis), and Left and Right Extensions to define the tapered shape. For ease of modeling, the Left and Right Cut Angles may be set equal to the brace angle or defined with a custom angle.

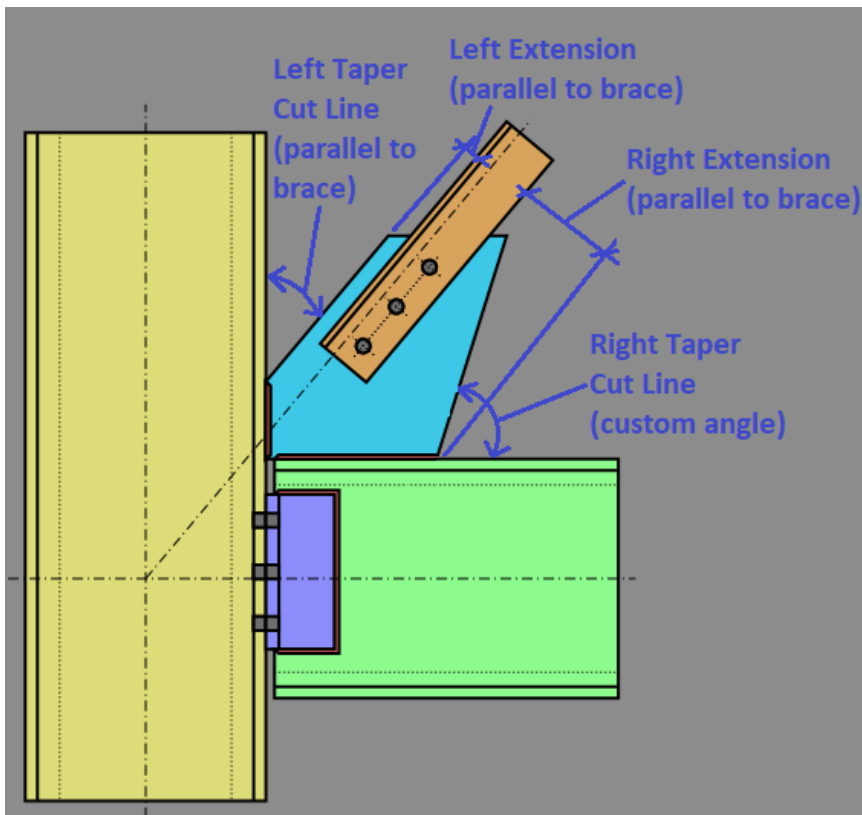
**Note:**

- When designing seismic vertical brace connections, the tapered gusset plate option is not available when you use the 8t Elliptical Offset option for the [Seismic Gusset Rotation](#) check.

Geometry Restrictions

- The connections between the gusset plate and the beam/column must be centered on the gusset plate.

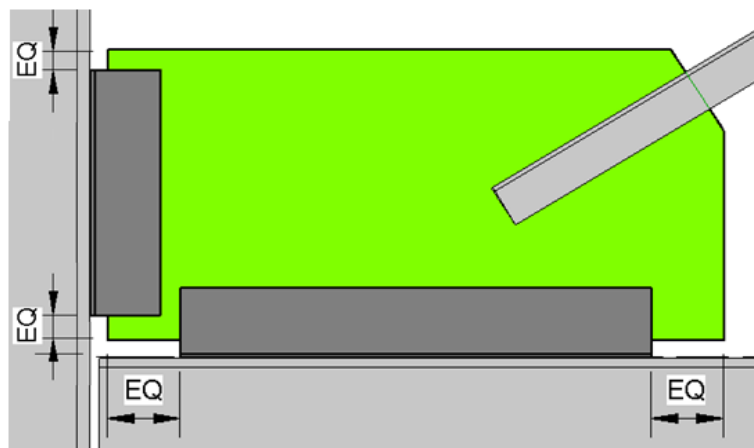

- For non-concentric workpoints the node defining the end of the brace must be within 18" of node defining the beam/column intersection. If they are not then the program will not recognize this as a vertical brace connection.

- For non-concentric workpoints in connections with both a top and bottom vertical brace, the end nodes of the brace must be within 36" of each other. If they are not then both braces will not be brought into RISAConnection.
- For non-concentric workpoints, if the workpoint falls along the beam then the brace above and the brace below must share a common workpoint.

Diagonal Brace Connection

The diagonal brace configuration supports braces framing into a column above, below, or above and below the beam. Each Diagonal Brace Connection consists of four sub-connections, illustrated with an example below:

- Brace-to-Gusset Connection (Bolted or Welded)
- Gusset-to-Column Connection (Double Clip Angle or Direct Weld)
- Gusset-to-Beam Connection (Double Clip Angle or Direct Weld)
- Beam-to-Column Connection (Shear Tab or Double Clip Angle)

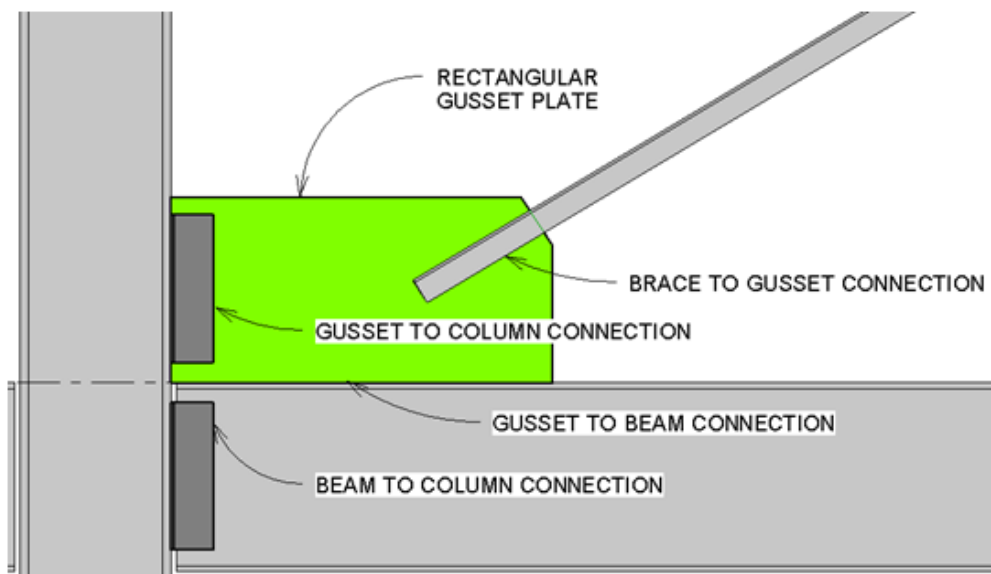

Note:

- At this time, RISAConnection only designs one sided connections, so braces framing into the opposite side of the column must be modeled as a separate connection.

See below for more information on [Gusset Plate](#) design and [connection eccentricity](#).

Analysis Methodology for the Diagonal Brace Connections

The program uses the Uniform Force Method to determine the distribution of forces within the gusset. This determines the forces on all of the sub-connections (i.e. Gusset to Beam) as well. For more information on this method see the AISC 14th Edition Manual, Page 13-3.

Width to Length Ratio

Under the **Brace** tab(s) on the **Connection Properties** grid, you can expand the **Gusset** section to set your desired **Width to Length Ratio**. The available options are shown below and your selection controls if your sub-connections will be designed for moment forces or not. The details for these options are shown below.

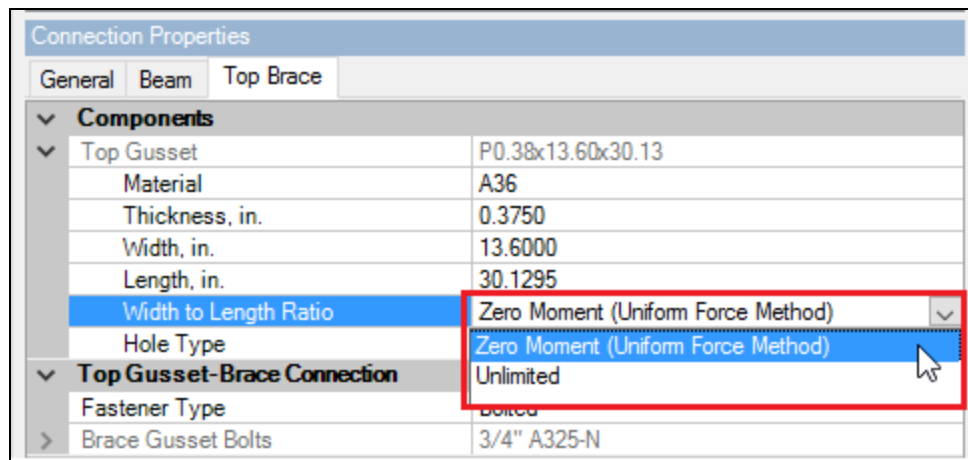

Zero Moment (Uniform Force Method)

When you select the **Zero Moment (Uniform Force Method)** option, RISACONNECTION will automatically limit your gusset plate dimensions so equation (13-1) from the *AISC 14th Edition* is met. This ensures that the free-body diagram of each sub-connection remains moment-free.

$$\text{Equation (13-1):} \quad \alpha - \beta * \tan\theta = e_b * \tan\theta - e_c$$

The design forces on each sub-connection interface will then be designed per equations (13-2) through (13-6). Please see page 13-5 of the *AISC 14th Edition* for further details on these calculations.

Unlimited Method

When you select the **Unlimited** option, RISACONNECTION will not make any attempt to limit your connection geometry. This means that the sub-connection interfaces may be subject to moments due to eccentricities.

The calculation and distribution of these moments is determined according to the procedure outlined in the *AISC 14th Edition Manual*, Page 13-10.

Note:

- For this method, RISACONNECTION assumes that Direct Weld sub-connections are more rigid than Clip Angle sub-connections.

Moments Due to Non-Concentric Work Points

For configurations which do not use concentric work points, you may define your eccentricity under the **Assembly** options on the **General** tab. When you do this, RISACONNECTION will automatically change your [Width to Thickness Ratio](#) analysis method to "**Unlimited**" so the connection can be designed for moment forces at the sub-connections.

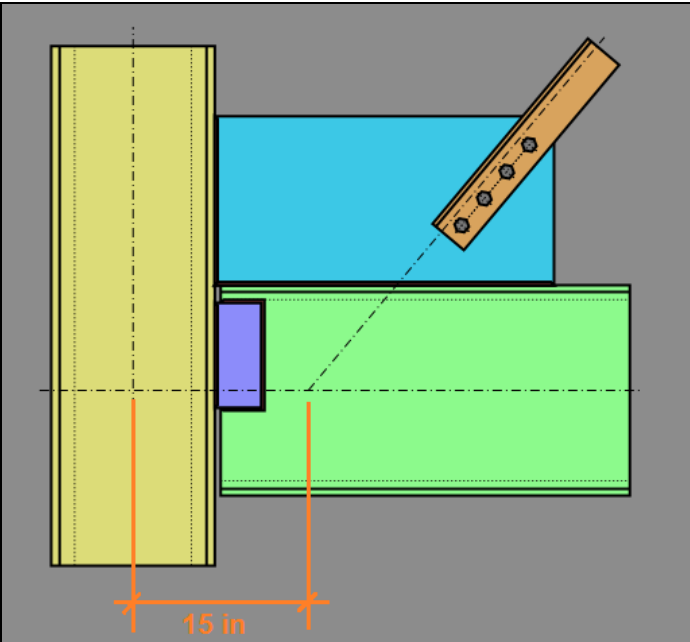

Connection Properties	
General Beam Top Brace	
Connection Title	Connection 3
Connection Type	Vertical Brace Diagonal Connection
Connection Category	
Braces	Above
Column Connection Type	Flange
Loading	
Shear Load, kips.	80.0000
Beam Axial Load, kips.	0.0000
Top Column Dist, in.	20.0000
Column Force, kips.	50.0000
Story Shear, kips.	0.0000
Top Brace Axial, kips.	-100.0000
Components	
Beam Section	W18x50
Column Section	W14x90
Top Brace Double Angle Section	LL3.5x3.5x6x6
Assembly	
Auto-Update Connections	Yes
Top Brace Angle from Vertical	40.0000
Workpoint Location	Along Beam
Dist from Column Centerline, in.	15.0000

The moment force is determined according to brace eccentricity from the idealized brace line of action which runs through the beam-column intersection (15 inches in the above example).

RISACONNECTION accounts for this moment using a procedure discussed in Section 2.2.1.8 of the *Handbook of Structural Steel Connection Design and Details, Second Edition, Akbar R. Tamboli*. This procedure calculates horizontal and shear forces at the gusset-beam and gusset to column interfaces using the Uniform Force Method as if the connection had no eccentricity. The procedure then adds in a moment due to eccentricity and attributes that moment to the gusset-beam and gusset-column interface.

RISACONNECTION is not capable of determining how much of this moment is taken by the beam or the column, as that is a function of the rigidities of the gusset-beam connection and the gusset-column connection, respectively. This distribution is determined by a **Moment Distribution Factor**, which is user-entered in the **Assembly** properties on the **Brace** tab.

Connection Properties		
General	Beam	Top Brace
Components		
>	Top Gusset	P0.38x14.44x29.03
Top Gusset-Brace Connection		
	Fastener Type	Bolted
>	Brace Gusset Bolts	3/4" A325-N
Top Gusset-Beam Connection		
	Type	Direct Weld
>	Beam Weld	E70
Top Gusset-Column Connection		
	Type	Direct Weld
>	Column Weld	E70
Assembly		
	Brace Min Clearance, in.	3.0000
	Brace WorkPoint Distance, in.	17.7518
	Brace/Gusset Overlap, in.	12.0000
	Gusset/Column Gap, in.	0.0000
	Gusset/Beam Gap, in.	0.0000
>	Gusset Clip	
>	Brace Bolts Edge Distances	
	Moment Distribution (Beam)	0.7500

Note:

- If the one edge of the gusset is welded and the other is bolted, then the program will automatically attribute the full moment to the welded connection.
- This procedure, while general and rational, does NOT produce the same results as *Special Case 1* of the *AISC steel manual*. This is because *Special Case 1* accounts for the eccentric moment by adjusting moments in the beam and column members themselves rather than by adding it into the gusset connection design.

Design for Moments in Gusset to Column or Gusset to Beam Connections

The total moments are determined at each sub-connection location based on the sum of the moments from gusset plate dimensions and the work point eccentricities. These moments can be accounted for in one of two ways:

The gusset will be designed for moment using the procedures established for extended shear tab connections or extended clip angle connections. Both of which have had their design procedures adjusted to account for the potential presence of a large axial forces in addition to the expected shear force.

Beam to Column Connection

For Diagonal Brace Connections the beam is assumed to be pinned to the column. Therefore, no consideration is made for distortion / deformation relationships which result in frame action. For more information on these considerations see Section 2.2.1.5 of the *Handbook of Structural Steel Connection Design and Details, Second Edition*, Akbar R. Tamboli.

Transfer Forces

By default RISACONNECTION designs diagonal brace connections as simple 2D connections without any interaction with braces on the other side of the column, or horizontal braces framing into the beam/column joint. However, you may also input transfer forces (axial and shear) to represent the load from other elements that are on the same side of the connection such as horizontal braces at the beam/column sub-connection. Note that transfer forces from elements on the opposing side of the column are not currently supported at this time.

Traditionally, the Uniform Force Method (and the Unlimited Method) has calculated the required shear and axial forces using the simplified (2D assumption) equations on the middle of page 13-5 of the AISC 14th edition Steel Design Manual. RISACONNECTION extrapolates this using simple statics to also include the **Axial Transfer Load** and the **Shear Transfer Load**. The axial transfer force is defined as the component (in plane of the connection) from the connected horizontal braces. The Shear Transfer Force is defined as the required shear force from connected horizontal braces.

Connection Properties		
General	Beam	Top Brace
Connection		
Connection Title	Connection 1	
Connection Type	Vertical Brace Diagonal Connection	
Seismic Detailing		
Seismic System	None	
Connection Category		
Braces	Above	
Column Connection Type	Flange	
Loading (LRFD)		
Shear Load, kips.	80.000	
Beam Axial Load, kips.	0.000	
Top Column Dist, in.	20.000	
Column Force, kips.	50.000	
Axial Transfer Force, kips.	-15.000	
Shear Transfer Force, kips.	50.000	
Story Shear, kips.	0.000	
Top Brace Axial, kips.	-100.000	

Beam/Column Axial Load: $H_{bc} = P_{bm} + TF_a + H_{b_t} + H_{b_b}$

Beam/Column Shear Load: $V_{bc} = V_{bm} + TF_v + V_{b_t} + V_{b_b}$

Where: P_{bm} = Axial Load in beam (user input)

V_{bm} = Shear load in beam (user input)

TF_a = Axial transfer force from connected horizontal braces (user input)

TF_v = Shear transfer force from connected horizontal braces (user input)

H_{b_t} = Required shear load at top gusset/beam per the Uniform Force Method eqn (13-5)

H_{b_b} = Required shear load at bottom gusset/beam per the Uniform Force Method eqn (13-5)

V_{b_t} = Required axial load at top gusset/beam per the Uniform Force Method eqn (13-4)

V_{b_b} = Required axial load at bottom gusset/beam per the Uniform Force Method eqn (13-4)

Chevron Brace Connection

The chevron brace configuration supports two braces framing into a beam from opposite directions. Each Chevron Brace Connection consists of three sub-connections, illustrated below:

- Left Brace-to-Gusset Connection (Bolted or Welded)
- Right Brace-to-Gusset Connection (Bolted or Welded)
- Gusset-to-Beam Connection (Double Clip Angle or Direct Weld)

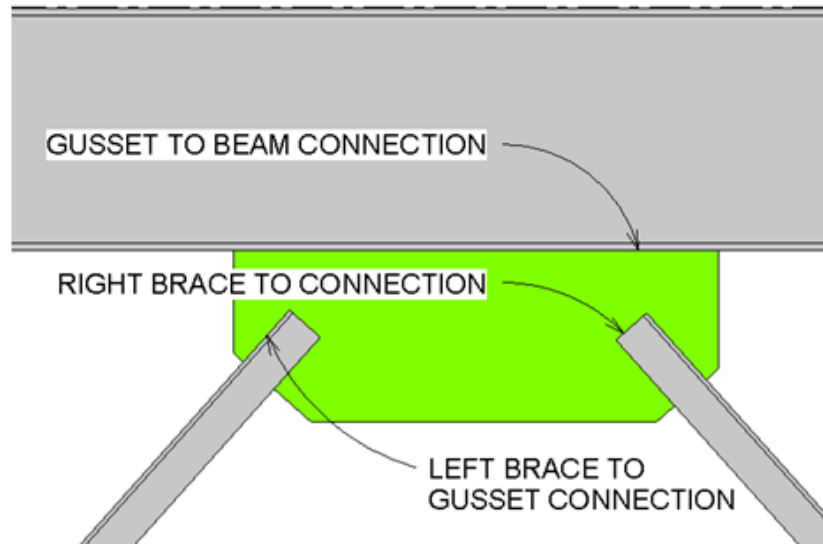

Note:

- At this time, RISACONNECTION only designs one sided connections, so braces framing into the opposite side of the beam must be modeled as a separate connection.
- Gusset Plates for Chevron Braces must be rectangular in shape.

See below for more information on [Gusset Plate](#) design and [connection eccentricity](#).

Design Methodology for Chevron Brace Connections (AISC 360-22)

When AISC 360-22 (16th Edition) is selected, RISACONNECTION determines the design methodology for the Chevron Brace connection based on the ratio of the gusset plate horizontal length to a minimum length threshold:

- Uniform Stress Method — used when $L_c \geq L_{min}$. This is the standard analysis path. RISACONNECTION performs the full set of section a-a and section b-b checks as described below.
- Concentrated Stress Method — applicable when $L_c < L_{min}$. At this time, RISACONNECTION uses the Uniform Stress Method only. When the Concentrated Stress Method condition is triggered, the program reports a warning message in the Design Method sub-check of the Required Load Calculation.

The Design Method sub-check is reported as the first sub-check within the Required Load Calculation limit state and displays L_c , L_{min} , and the applicable method. The absolute value of L_{min} is always reported.

New Beam Shear Yield Check (AISC 360-22)

For AISC 360-22 Chevron Brace connections using the Uniform Stress Method, a new Beam Shear Yield check is reported on the GussetBeam tab. The required shear is calculated per AISC 360-22 Eq. 13-30:

$$R_{req} = 2M_{aa}/L_c$$

The available strength is calculated using the same procedure as for the Column/Beam Shear Tab Shear connection, with appropriate adjustments for Tube and Pipe beams (using Cv2 per Chapter G). Note that when the Concentrated Stress Method condition is triggered ($L_c < L_{min}$), the Beam Shear Yield available strength is still calculated and used in the Required Load Calculation, but the check is not separately reported.

For earlier AISC editions, this check is not performed.

Analysis Methodology for Chevron Brace Connections

The program uses statics to determine the distribution of forces within the gusset. Gusset design is assumed to be controlled at one of two section cuts, as shown in the illustration below:

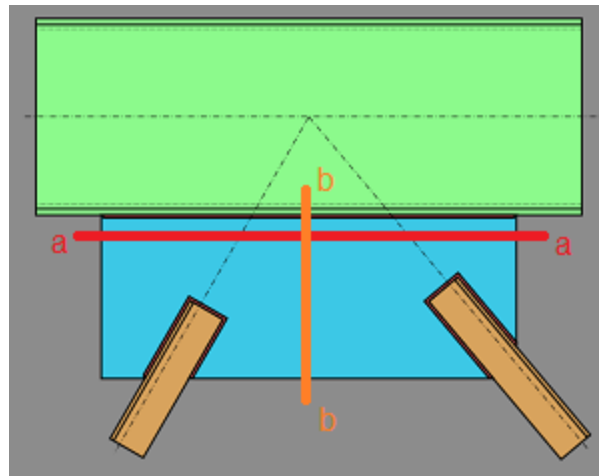

Section a-a

The shear and axial force at section a-a are calculated as the net horizontal and vertical forces from the braces. The in-plane moment at section a-a is calculated as the net moment induced by both braces. The moment induced by each brace is calculated as the force in the brace, multiplied by the distance between the center of the beam-gusset interface and the nearest point along the brace's centerline (shown dashed above).

Section b-b

The shear (V'), axial force (N'), and in-plane moment (M') at section b-b are calculated using the method of sections (statics). The derivations are shown below.

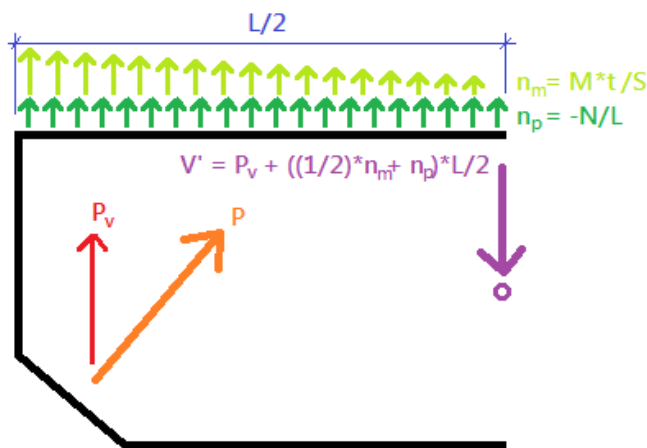

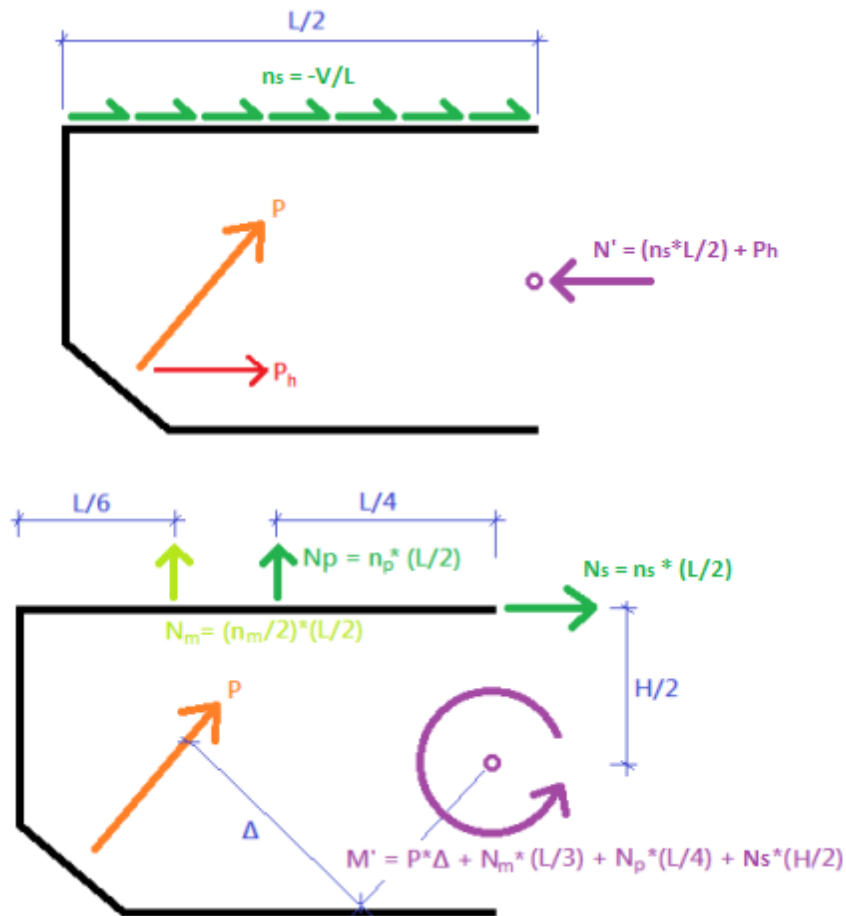
**Note:**

- Technically the gusset design *could* be controlled by forces at/about a location other than the two locations that RISACONNECTION checks. However, the likelihood that there are greater forces elsewhere, or that those forces are significantly greater than the ones calculated is very small.

Definition of L_c — Length of the Gusset-to-Beam Connection (AISC 16th Edition)

When designing a Chevron Brace connection per AISC 16th Edition, the parameter L_c — the length of the gusset-to-beam connection — is used to determine whether the Uniform Stress Method or the Concentrated Stress Method governs the required load calculation. Specifically, when $L_c \geq L_{min}$, the Uniform Stress Method applies; when $L_c < L_{min}$, the Concentrated Stress Method is required per AISC 16th Edition page 13-17.

L_c is defined as the horizontal length of the gusset plate footprint along the beam, measured at the gusset-to-beam interface. The measurement of L_c varies depending on the gusset-to-beam connection type and the bolt/weld configuration, as illustrated below.

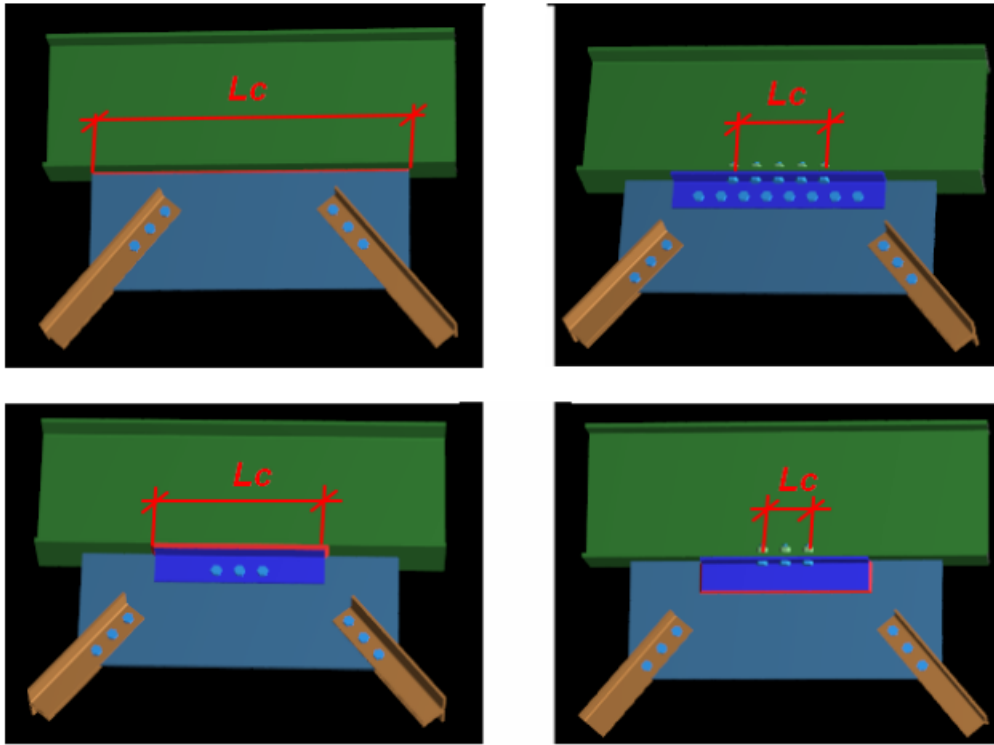
**Note:**

- L_c is not the same as L_p (the full gusset plate length). L_p is the overall horizontal dimension of the gusset plate, while L_c is the effective connection length at the beam interface.
- For direct weld connections, L_c equals the length of the horizontal weld along the beam.
- For clip angle or bolted connections, L_c equals the distance between the extreme bolt of the gusset-to-beam bolt group.
- This parameter applies to AISC 16th Edition only. For AISC 15th Edition and earlier, the design method selection is not required and L_c is not reported.

Analysis Methodology for Extended Shear Tab without Gusset

Similar to the Chevron brace connection, the program uses statics to determine the distribution of forces within the gusset. However in contrast to the chevron brace connection where a single section b-b cut is taken at the center of the gusset, several section b-b cuts are taken at the shear tab for the extended shear tab connection and the cut producing the highest largest code check is used. The reasoning for this is because the addition of a beam axial force into the shear tab between two braces produces more fluctuation of the resulting forces depending on where the section b-b cut is taken.

For each extended shear tab without gusset connection, the critical section is assumed to occur outside of the beam bolt groups and somewhere in between the beam bolt group and brace (upper or lower). 11 equidistance section cuts are taken between the extents of the beam bolt groups and braces (i.e. 22 section cuts in total for the case where there are top and bottom braces). The results are then only reported for the critical section, that is, the section producing the highest unity check.

See figure below delineating how the section cuts are taken internally.

Section b-b cuts

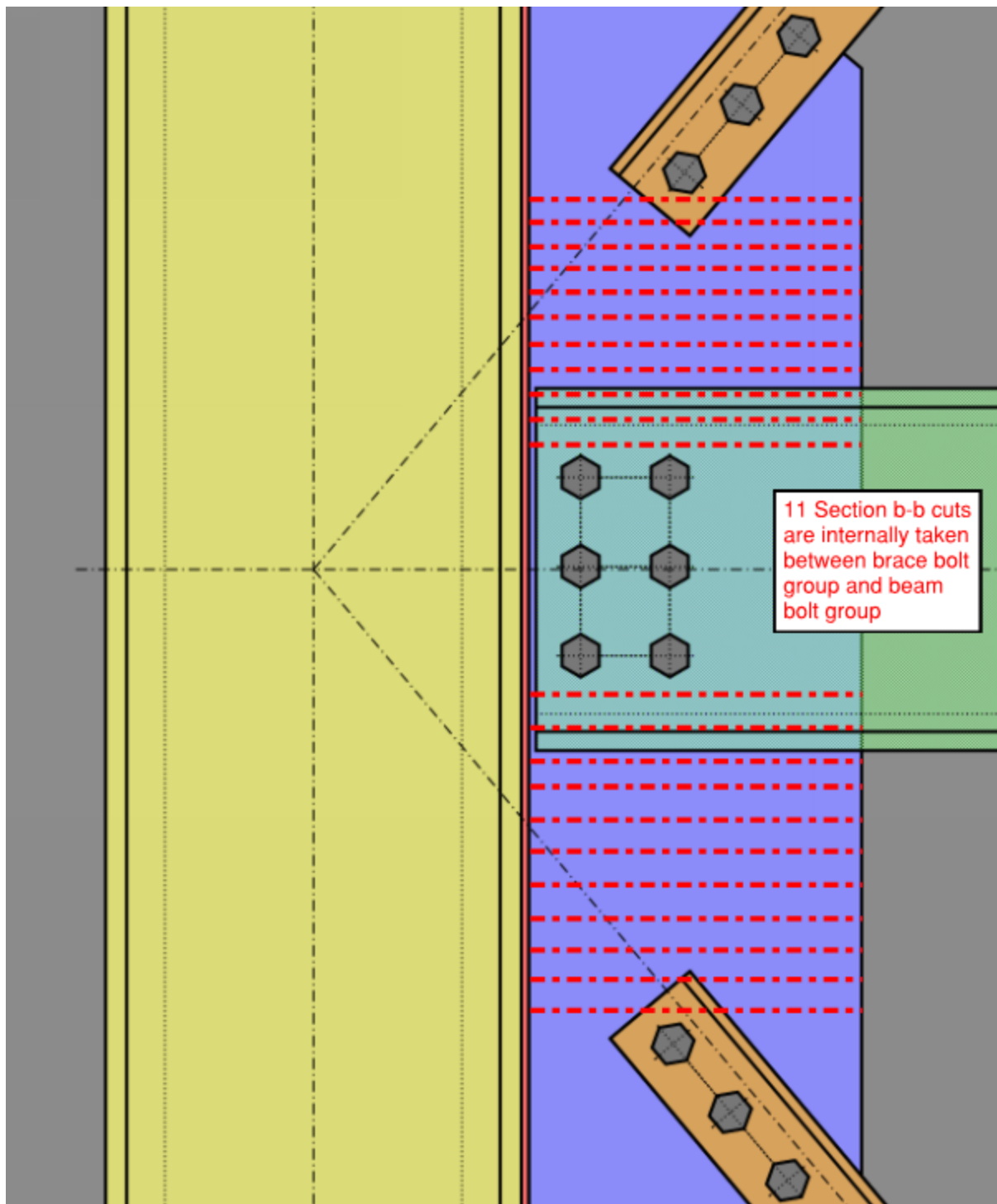

General Assumptions for Extended Shear Tab Connections

Assumptions of UFM for Extended Shear Tab with gusset

- The uniform force at the column is at the face of the column flange as opposed to the column bolt line and gusset-to-beam interface

- Beta will always be centered on the gusset plate. This means that the connection between the gusset plate and column will be centered on the gusset plate.

Assumption for Gusset Failure Plane

For the extended shear tab the length of the gusset failure plane is conservatively taken as the spacing between the bolts plus a 1.5" extension on both sides. In the instance that the bolt edge is less than 1.5", the program will use that bolt edge distance instead.

This can be expressed as the following:

$$L_{failure_plane} = ((N_{bolts} - 1) \cdot Spacing) + (2 \cdot \min(1.5 \text{ in}, L_{edge}))$$

There is not clear direction as to how much of the shear tab should be used for this failure plane however the basis for the program assumption aligns with the assumptions used in the AISC seismic manual design examples.

Bolt Group Eccentricity

Ex = Horizontal distance from ace of support to center of bolt group

Ey = Vertical distance from center of bolt group to center of beam

K, Effective Length for Plate Compression (Whitmore) Check in Plate/Beam sub-connection

The determination of the K (effective length factor) is based on guidance provided AISC Design Guide 29 where K=0.5 is used if the gusset is supported on two sides and K=1.2 if it is supported on one side only. K = 0.65 is used when the gusset plate is used in a Chevron configuration.

Column Web Yielding and Column Web Crippling Checks (WF Columns)

For both the extended shear tabs (without and with gusset), the program will always assume the compressive concentrated load on the member is close to the column. This translates to the following conditions when determining the capacities for these limit states:

Column web yielding: Concentrated force is less than or equal to the depth of the member -> AISC 15th Ed Eqn J10-3

Column web crippling: Concentrated force is less than d/2 -> AISC 15th Ed Eqn J10-5

Knee Brace (Kicker Brace) Connection

The Knee Brace configuration supports a single brace framing into either a beam or a column. The brace is assumed to only carry axial load which means that the gusset to beam/column connection is only designed for axial and shear forces. If the brace connection is eccentric, the moment due to eccentricity will also be reported, although not used for design.

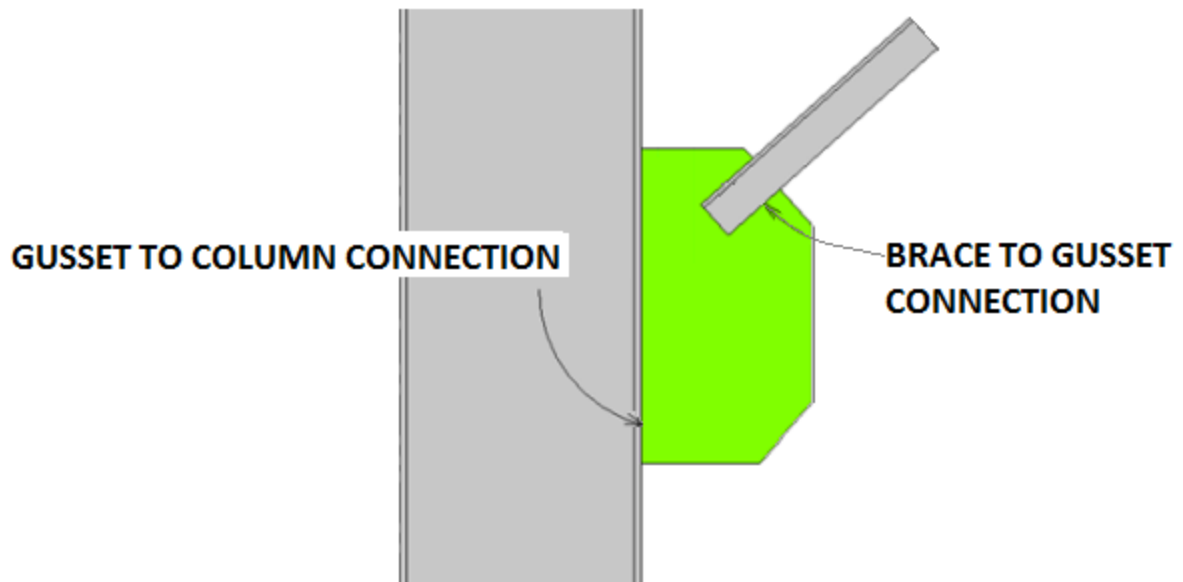
**Note:**

- At this time, RISAConnection only designs one sided connections, so braces framing into the opposite side of the beam must be modeled as a separate connection.

See below for more information on [Gusset Plate](#) design and [connection eccentricity](#).

Knee Brace Work-Points

Because a Knee Brace frames into a beam or a column, not both, there is no beam to column intersecting work-point. Therefore, we consider the work-point to be the brace center-line intersection with the centroid of the gusset to beam (or column) connection.

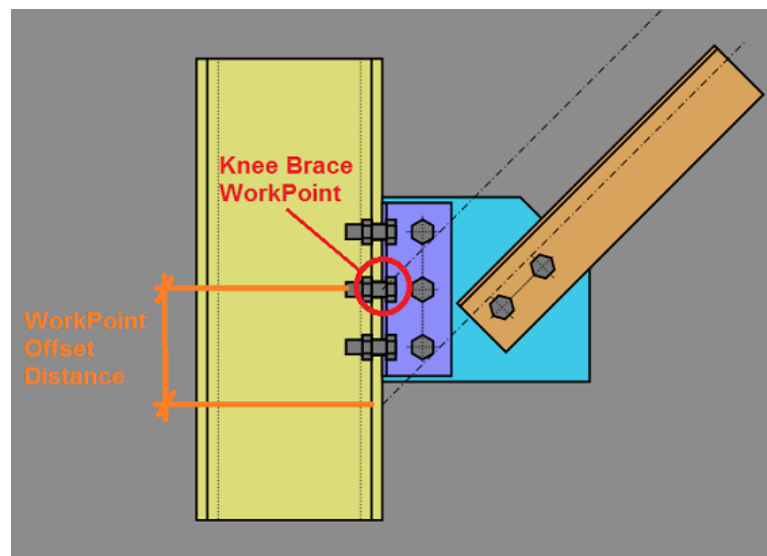
***Analysis Methodology for Knee Brace Connections***

The program uses simple statics to determine the force components at the gusset to beam/column connection.

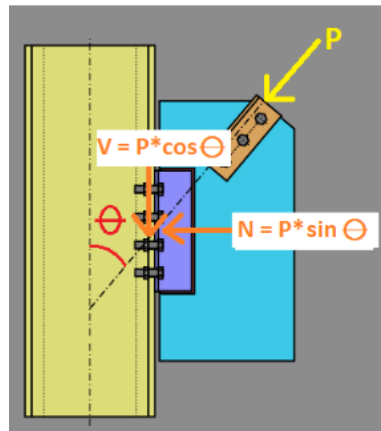

Gusset Plate Design

The Whitmore section is a design term used to indicate the portion of the gusset plate that is effective in resisting the tension or compression forces transferred to it by the vertical brace. As shown below (and in Figure 9-1 of the *AISC 14th Edition Manual*), the Whitmore section assumes that the gusset plate stress spreads out at a 30 degree angle from the first point of connection (along the line of the brace force). It then terminates at the last point of connection between the brace and gusset. This length is then defined as the width of the Whitmore Section.

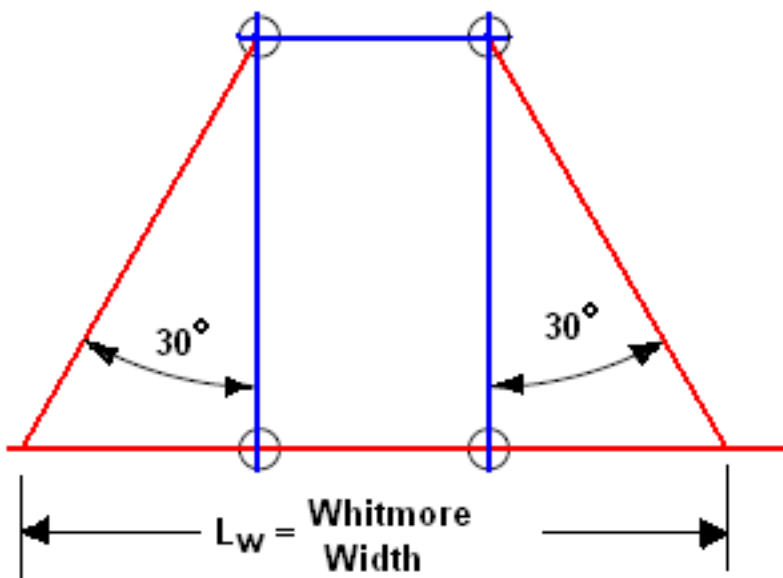

Special Cases

The calculation of the Whitmore width is straight forward when the width remains entirely within the gusset. In cases, where the width extends into the beam or column, RISACONNECTION assumes a constant thickness equal to the gusset plate thickness.

In cases where the geometry of the plate produces an eccentricity in the Whitmore section, RISACONNECTION will conservatively use a reduced effective width (see the article "The Whitmore Section" written by Thornton and Lini in the July 2011 issue of *Modern Steel Construction*).

Tension Checks

The Whitmore section will be checked against both yield and rupture. With the width of the section as described above and the thickness of the section equal to the thickness of the gusset plate (or beam / column if a portion of the Whitmore section extends into the beam / column).

Compression Checks

For compression, the gusset plate code check requires that Whitmore Section be viewed as an equivalent column. The width of the column is merely the width of the Whitmore section as discussed above. However, the compression checks also require an equivalent unbraced length KL for buckling checks. Currently the unbraced length used for the gusset compression checks is the unbraced length at the center of the Whitmore section (L_2 as shown in the image below).

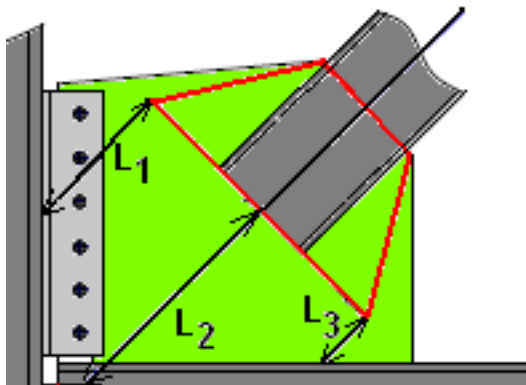

The K value used for the Gusset plate is assumed to be 0.50 for gussets that are supported along two edges and 1.2 for gussets supported along only one edge. $K = 0.65$ is used for a Chevron brace configuration.

Graphical View of the Whitmore Section

RISACONNECTION includes toggle buttons to view the **Whitmore Section** and unbraced length. These are available on the **2D Side View** graphical view for vertical brace connections.

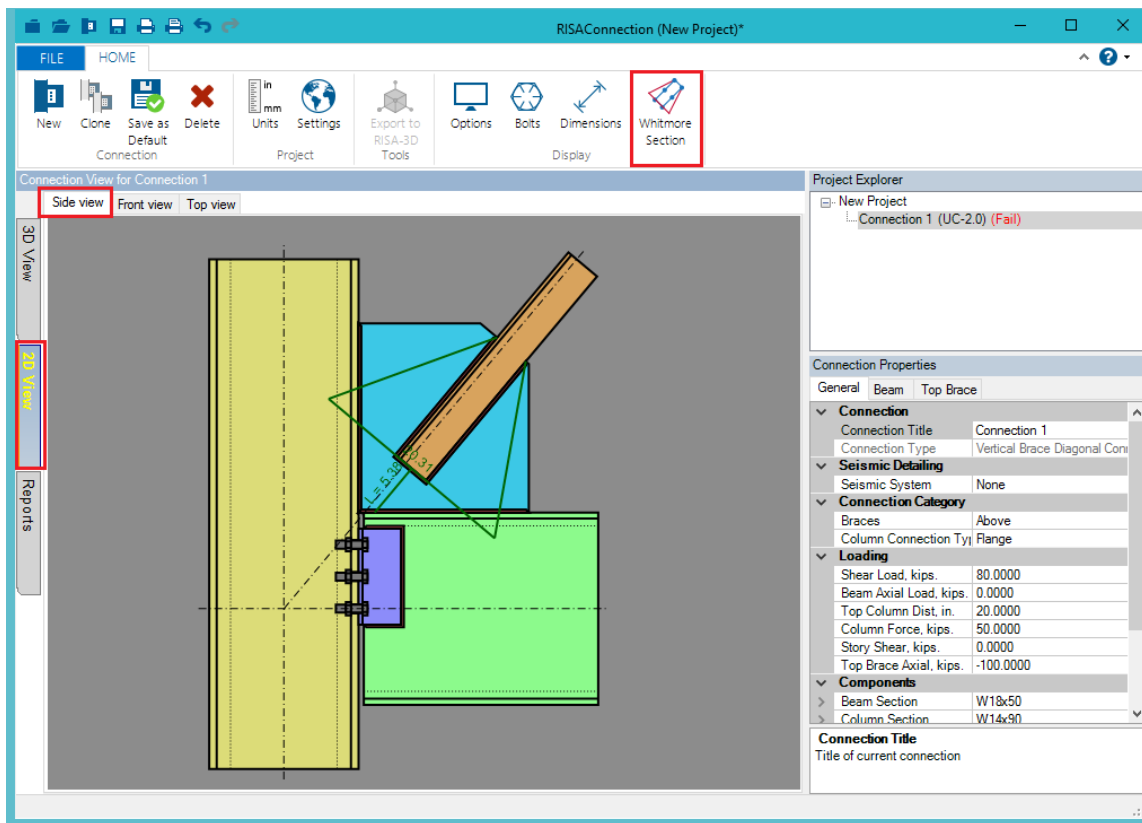
**Note:**

- The outline of the Whitmore Section will be green when the geometry can be verified. If the outline extends beyond the extents of the connection the outline will display as red to indicate that the Whitmore area calculation cannot be completed.

Wide Flange Brace Members with Clip Angle Gusset Connections

When a brace member is defined as a Wide Flange, it will connect to the gusset plate using claw (clip) angles. Because of the complexity of the brace to gusset connection, it is no longer appropriate to assume that the axial load is applied along the centerline of the brace. Instead, the load on the gusset plate is proportional to the cross sectional area of the connection element. This design methodology comes from *Example II.C-2 from the AISC Design Examples Version 14.1*.

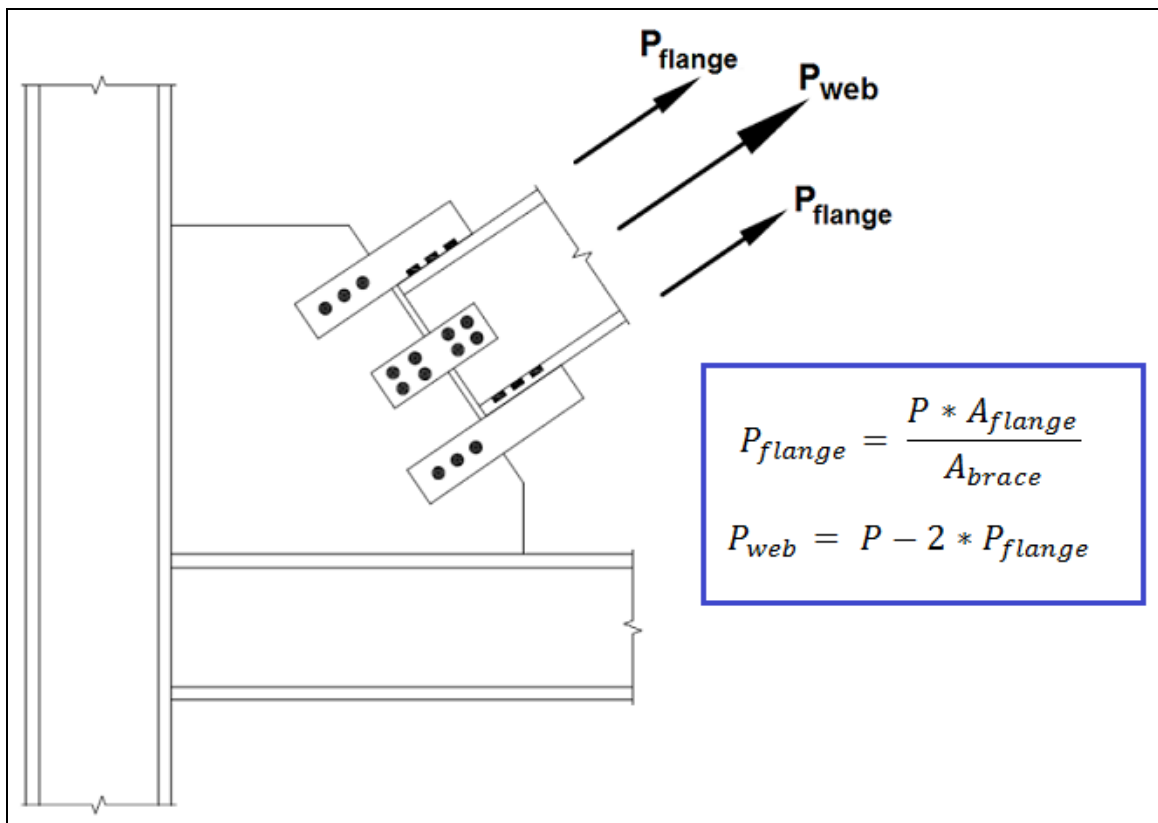

Wide Flange Brace Connection Whitmore Section Assumptions

When the brace is in compression, RISACONNECTION will conservatively calculate the Whitmore section and unbraced length based on the connection between the gusset and the claw angles.

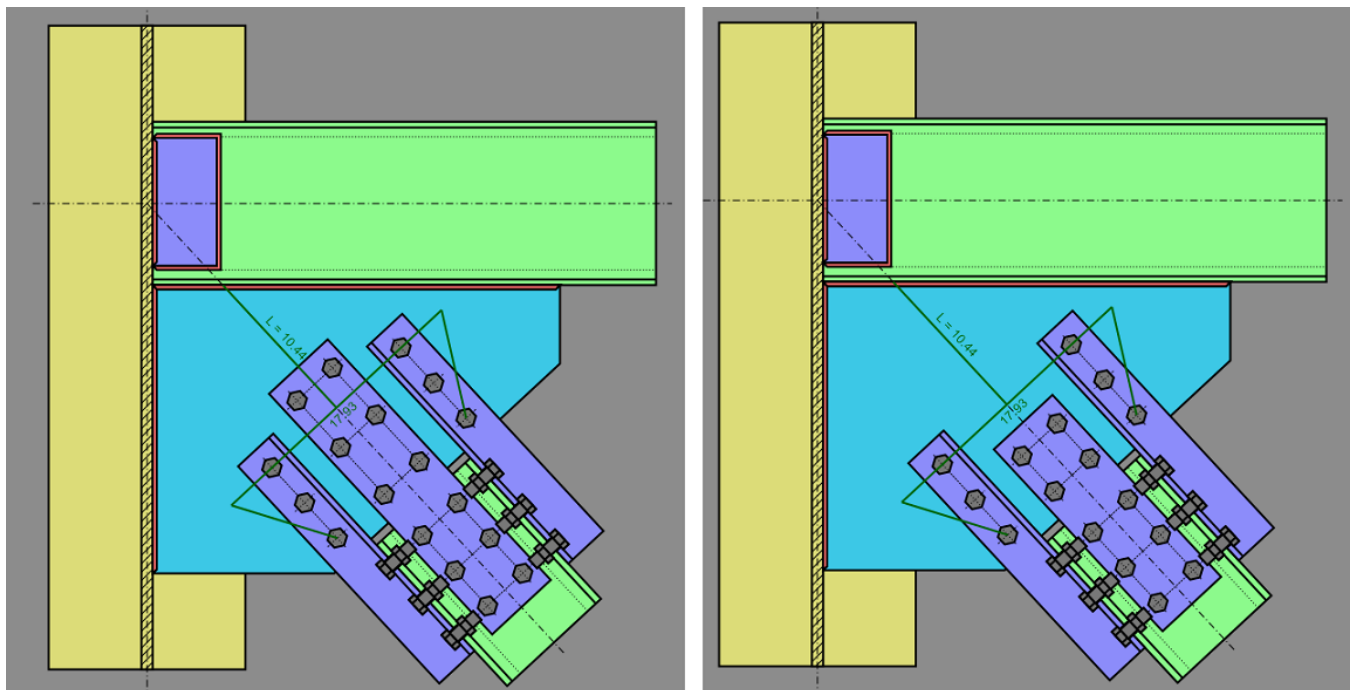

Wide Flange Brace Connection Plate Tearout Assumptions

When the brace is in tension, RISACONNECTION will calculate the Overall Plate Tearout with the following assumptions:

- When the claw angles are longer than the web plate:

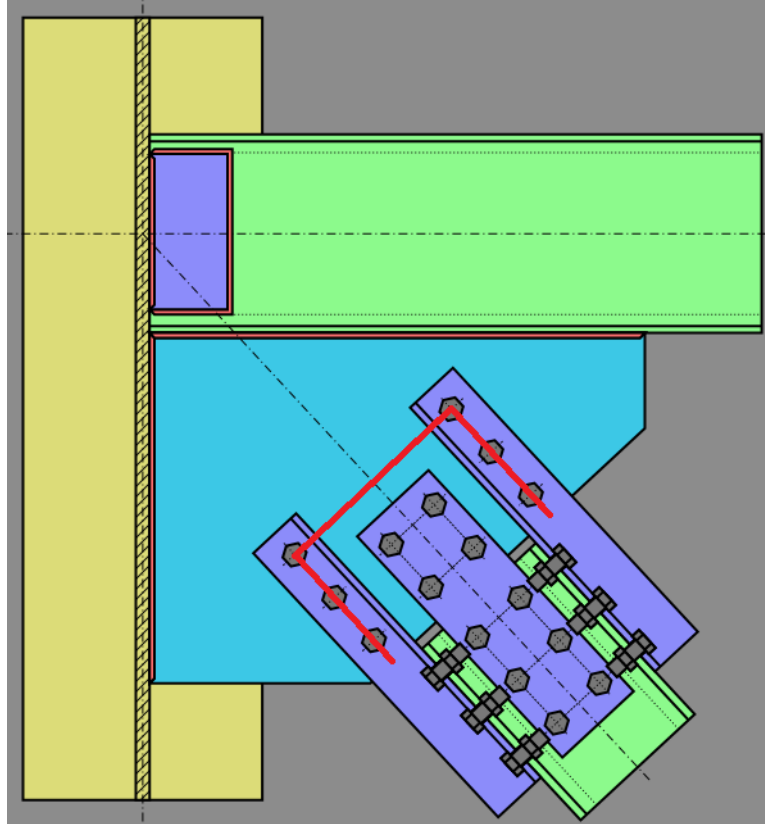

- When the claw angles are shorter than the web plate:

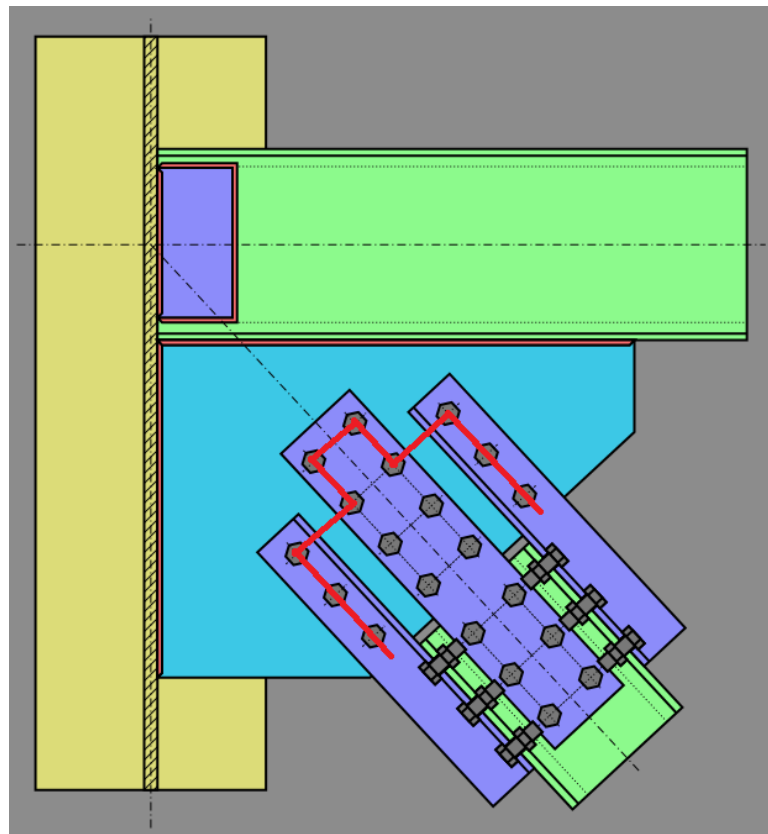

Connection Eccentricity

Many of the diagonal brace connections result in a small connection eccentricity. This eccentricity may be minor for cases like the thickness of a plate (e.g. HSS brace with an end-tee or slotted plate connection), or it may be more significant (e.g. WT brace with its flange bolted to the gusset plate). The design codes are not entirely clear on how to address this. Therefore, RISACONNECTION has used material outside the code specifications to arrive at the following design procedure:

Minor Eccentricities

When the eccentricity is the thickness of a single plate or gusset, then the program considers this eccentricity in the connection design using a procedure given in *AISC Design Guide 24, Hollow Structural Section Connections*. Section 5.2 of this design guide covers End Tee connections and gives formulas 5-1 and 5-2 to address the issue of interaction between the compression or tension in the tee stem and the flexure due to the connection eccentricity.

Major Eccentricities

Single angle braces or WT braces where the flange of the WT is connected to the gusset plate will generally result in more significant eccentricities. While the code is silent on this subject, RISACONNECTION chooses to ignore this moment in the design of the connection itself. For more information on this assumption, see the article "Horizontal Bracing" by Dowswell, Brice, and Blain from the July 2010 issue of *Modern Steel Construction*. The idea is that the moment will be primarily resisted by the brace member instead of connection. The program will report the magnitude of this moment so that the engineer may manually include it in the design of the brace member itself.

Seismic Vertical Brace Connections

Design for seismic vertical brace connection detailing is done per the *AISC Seismic Design Manual, 3rd Edition & 2nd Edition* which contains the *AISC 341-16/10 Seismic Provisions for Structural Steel Buildings*.

The following seismic connections are available:

- Braced Frame Systems:
 - Vertical Diagonal Brace Connection (OCBF & SCBF)
 - Chevron Brace Connection (OCBF & SCBF)
- Moment Frame Systems:
 - See the [Seismic Moment Connections](#) topic for information on which seismic moment frame connections are available.

Note:

- Unless otherwise specified, all code references below are to AISC 341-16 and AISC 358-16.
- Seismic design in RISACONNECTION is limited to the current edition of the US design code. No results will be given if you select any other design code.
- Seismic vertical brace design is only available for *concentric* braced connections. An error will be reported if the brace work point eccentricity exceeds $d_{\text{beam}}/10$. This is an arbitrary internal tolerance to limit the eccentricity.

How to Create a Seismic Vertical Brace Connection

Starting from Scratch in the Stand-Alone Version

If you are using RISACONNECTION as a stand-alone program, then you can define your seismic vertical brace connection as follows:

1. Start a new model and select your Vertical Brace connection type. Applicable connection types are:
 - a. Vertical Brace Diagonal Connection
 - b. Vertical Brace Chevron Connection

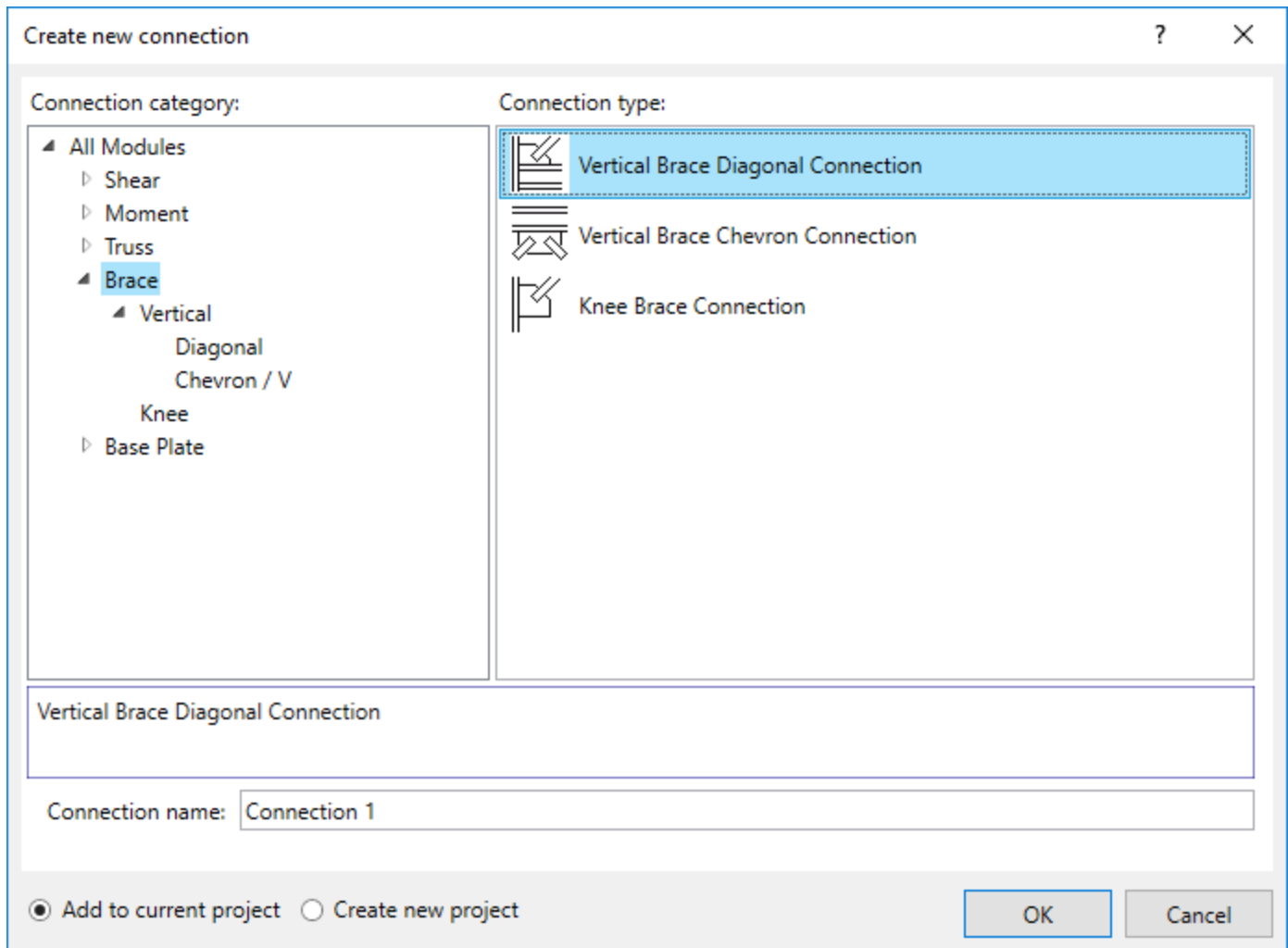

2. Select your **Seismic System**.

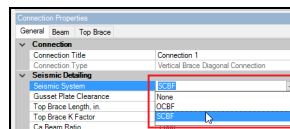

3. Enter the appropriate [seismic input](#).

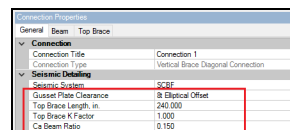

4. Seismic braces will be designed for the maximum case of tension and compression loading. Therefore you must also enter the brace tension and compression loads. See below for more details on how the braces are designed.

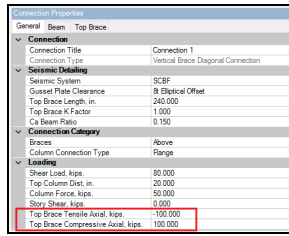

Importing a Connection from a RISA-3D Model

If you are using the integration between RISA-3D and RISACONNECTION to create your model, then you can define your seismic connection as follows:

1. If you are using RISA-3D on its own, then you must apply both a "Brace Seismic" Connection Rule and a Seismic Design Rule to the member.

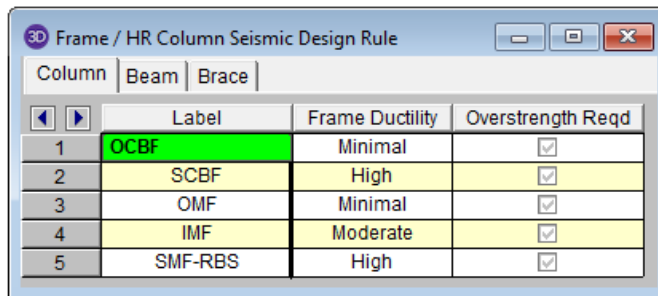
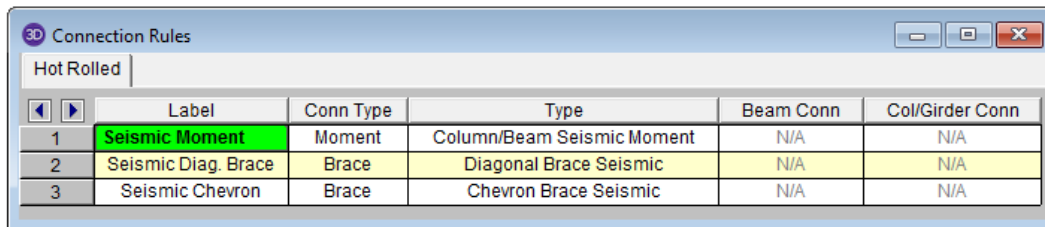

2. Make sure to solve in RISA-3D for your *seismic detailing results*. If you do not have seismic detailing results in RISA-3D, then the information cannot be exported to RISACONNECTION. For more information about seismic detailing results, see the RISA-3D Help file topic "Seismic Detailing".
3. When exported into RISACONNECTION, the program will determine the **Connection Type, Seismic System**, seismic input values, and governing brace tensile and compressive axial loads based on the applied Seismic Design Rule and the RISA-3D solution results. Once in RISACONNECTION, these cannot be changed.

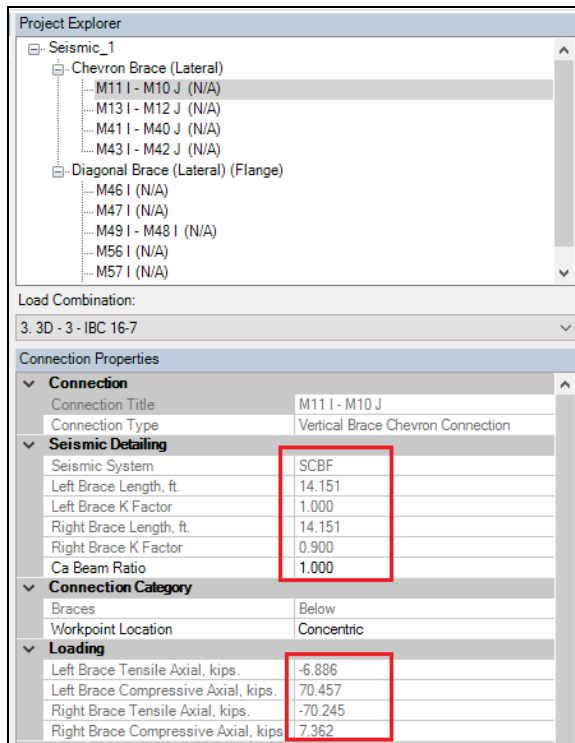

Determining the Seismic System

The integration between programs uses the following "translation" to determine the **Seismic System**:

RISA-3D Input		RISACONNECTION EXPORT	
Connection Rule	Seismic Design Rule	Connection Type	Seismic System
	Frame Ductility		
Diagonal Brace Seismic	Minimal	Vertical Brace Diagonal	OCBF
	High	Vertical Brace Diagonal	SCBF
Chevron Brace Seismic	Minimal	Vertical Brace Chevron	OCBF
	High	Vertical Brace Chevron	SCBF

RISA-3D Imported Loads

Due to the nature of seismic brace design, the design loads for the connection are not always based on a load combination from RISA-3D. Therefore, the results for an integrated RISA-3D model will not report a governing load combination. Please see the [Consideration of Input or Imported Loads](#) section below.

Note:

- It is not possible to import a vertical brace connection from RISAFloor since RISAFloor does not allow diagonal members.

Seismic Input Values

The following seismic input values are available for seismic vertical brace connections:

- **Gusset Plate Clearance** - Gusset plate clearance option for the accommodation of the brace buckling check.
 - The options are a **2t Linear Offset** and a **8t Elliptical Offset**.
 - This selection is only applicable to vertical diagonal brace SCBF connections.
 - See [below](#) for more information on the Seismic Gusset Plate Rotation Capacity/Clearance check.
- **Brace Length** - Brace member length
- **Brace K Factor** - Brace effective length factor, K

- **Ca Beam Ratio** - Ratio of required strength to available strength of beam members in vertical diagonal brace connections. This value is used per *AISC 341-16 Table D1.1* to calculate the width to thickness ratios.
 - Because of the multiple possible load cases in seismic braces, it is not clear within RISAConnection which P_u/P_a (axial load in the beam) to use to calculate this value. Therefore, we ask for this as a customer input based upon your engineering judgment.

Limitations- Seismic Vertical Braces

Below is a list of limitations regarding the seismic vertical brace design:

- Seismic design is not supported under the Canadian design code.
- Seismic design is not supported under the *AISC 341-05 (1st edition) Seismic Design Manual*.
- RISAConnection does not design stability bracing per *AISC 341-16 section D1.2*.
- Code provisions for limitations on the spacing of connectors for double angle members are not checked at this time.
- Code provisions for Seismically isolated structures are not currently considered.
- For diagonal braced connections, the beam axial force is calculated based on the assumption that you have an equal ("paired") connection on the opposite side of a frame. Please see the [Story Force](#) calculation below for details on this calculation.
- SCBF Vertical Brace Connections will automatically set the gusset to column and gusset to beam connections to a direct weld. This is necessary in order to properly calculate the geometry of the offset hinge lines for the [Seismic Gusset Rotation Capacity/Clearance](#) check.

Seismic Brace Design Force Calculations

Seismic vertical brace connections must consider several possible envelopes of loading. This is necessary in order to meet the following two requirements:

- Per *AISC 341-16 Chapter F*, the connection may be required to be designed to the expected strength of the brace.
- The braces must be designed for tension and compression loading (i.e. the connection must be able to withstand reversible loading).

This complicated procedure makes seismic vertical braces unlike any other connection in the program. For RISA-3D integrated models this means that there is not always a governing load combination that controls the design. For stand-alone models, this means that the input brace loads are not always the governing loads used to design the connection.

Consideration of Input or Imported Brace Loads

First, the input (or RISA-3D imported) loads are compared to the expected brace strengths per the *AISC 341-16*. Depending on if the connection is an OCBF or a SCBF the governing design forces may be the calculated expected strength of the brace, rather than the input/imported loads. This comparison is displayed in detail in the **Controlling Load Combination** calculation on the **Seismic** tab of the results report:

Calculation of the expected strength of the brace in tension and compression per the AISC Seismic Design Manual

Determination of the controlling tension and compression design loads in the braces

Controlling Load Calculation		n/a
Bottom Brace Exp. Ten. Strength		
F_{y-bot}	36.0000 ksi	AISC 341-10 section F1.6a(1) Minimum yield stress of the bottom brace material
R_{y-bot}	1.5000	Ratio of expected yield stress to minimum yield stress of the bottom brace material
A_{br-bot}	4.7900 in ²	Area of the bottom brace
$P_{exp-t-bot}$	258.6600 kips	Bottom brace expected strength in tension = $R_y * F_y * A_{br}$
Bottom Brace Exp. Comp. Strength		
AISC 341-10 section F1.6a(2)		
K_{bot}	1.0000	Effective length factor of the bottom brace
L_{bot}	23.4307 ft	Length of the bottom brace
E_{bot}	29000.0000 ksi	Elastic modulus of the bottom brace material
r_{y-bot}	1.5359 in	Radius of gyration about the weak axis of the bottom brace
F_{e-bot}	8.5409 ksi	Elastic buckling stress per AISC 360-10 eqn. (E3-4) = $(\pi^2 * E) / ((K * L) / r_y)^2$
$F_{cre-bot}$	7.4904 ksi	Critical stress per AISC 360-10 eqn. (E3-3) = $0.877 * F_e$
$P_{exp-c-bot}$	40.9021 kips	Bottom brace expected strength in compression = $\min(R_y * F_y * A_{br}, 1.14 * F_{cre} * A_{br})$
Governing Brace Strength in Tension		
$P_{br-t-bot}$	-32.3826 kips	User input tensile axial load in bottom brace
$P_{des-t-bot}$	-32.3826 kips	Design tensile load in bottom brace member = $\min(P_{br-t-bot} , P_{exp-t-bot} / 1.5)$ (negative for tension)
Governing Brace Strength in Compression		
$P_{br-c-bot}$	32.6487 kips	User input compressive axial load in bottom brace
$P_{des-c-bot}$	27.2681 kips	Design compressive load in bottom brace member = $\min(P_{br-c-bot}, P_{exp-c-bot} / 1.5)$

For more details on the specifics of this calculation, please see the [OCBF](#) and [SCBF](#) sections below.

Seismic Loading Directions

Once the controlling brace loads in tension and compression are determined, the connection also must consider the application of these controlling loads to the connection in all possible cases (i.e. the connection must consider applied loading and opposite/reversible loading).

For OCBF frames, there are just two directions to consider. Because SCBF connections require both a pre- and post-buckling strength analysis, there will be four directions to consider. Please see the chart below for clarification. For more information on the two types of analyses (i and ii) for SCBF, please see [SCBF Connection Strength](#), below.

Diagonal Braces:		
OCBF Case	Top Brace	Bottom Brace
S1	Tension	Compression
S2	Compression	Tension

SCBF Case	Top Brace	Bottom Brace
S1	Tension	Compression (Analysis i)
S2	Tension	Compression (Analysis ii)
S3	Compression (Analysis i)	Tension
S4	Compression (Analysis ii)	Tension

Chevron Braces:		
OCBF Case	Left Brace	Right Brace
S1	Tension	Compression
S2	Compression	Tension

SCBF Case	Left Brace	Right Brace
S1	Tension	Compression (Analysis i)
S2	Tension	Compression (Analysis ii)
S3	Compression (Analysis i)	Tension
S4	Compression (Analysis ii)	Tension

The applicable directional loading cases are reported in the **Seismic Loading Combinations** line of the **Seismic** tab of the results report.

Seismic Loading Directions		n/a
Loading Direction SD1		<i>Brace in tension, story force opposite in compression (i)</i>
$P_{top-SD1}$	-270.0000 kips	<i>Top brace design load per loading direction SD1</i>
Loading Direction SD2		<i>Brace in tension, story force opposite in compression (ii)</i>
$P_{top-SD2}$	-270.0000 kips	<i>Top brace design load per loading direction SD2</i>
Loading Direction SD3		<i>Brace in compression (i), story force opposite in tension</i>
$P_{top-SD3}$	232.3467 kips	<i>Top brace design load per loading direction SD3</i>
Loading Direction SD4		<i>Brace in compression (ii), story force opposite in tension</i>
$P_{top-SD4}$	69.7040 kips	<i>Top brace design load per loading direction SD4</i>

Design Force Calculations per Loading Direction

The loads at each sub-connection interface (gusset/column, gusset/beam, beam/column) are then calculated per the Uniform Force Method for each loading direction case. The full details of each of these calculations are shown in the **Seismic Load Distribution Calculations** on the **Seismic** tab of the results report.

Seismic Load Distribution (Loading Direction SD1)		n/a
$P_{top-SD1}$	-100.0000 kips	Top brace load per loading direction SD1, see "Seismic Loading Directions"
V_{bm}	80.0000 kips	User-input shear force in beam
Beam Story Force:		
$G_{top-SD1}$	-100.0000 kips	Design tensile load in top brace member
$O_{top-SD1}$	100.0000 kips	Assumed opposite side top brace force
SF_{SD1}	-163.8304 kips	Story force at beam level for loading direction SD1 (Per AISC 341-10 example 5.3.5 methodology)
P_{bm-SD1}	-81.9152 kips	Axial force in beam at connection = $SF_{SD1}/2$ (Per AISC 341-10 example 5.3.5 methodology)
Top Gusset/Column Connection:		
$V_{colSD1-top}$	-24.6856 kips	Top gusset/column vertical load per AISC 14th, eqn. (13-2)
$H_{colSD1-top}$	-25.4116 kips	Top gusset/column horizontal load per AISC 14th, eqn. (13-3)
Top Gusset/Beam Connection:		
$V_{bmSD1-top}$	-32.6721 kips	Top gusset/beam vertical load per AISC 14th, eqn. (13-4)
$H_{bmSD1-top}$	-56.5036 kips	Top gusset/beam horizontal load per AISC 14th, eqn. (13-5)
Beam /Column Connection:		
V_{bcSD1}	47.3279 kips	Beam/column vertical load per AISC 14th, page 13-5 = $V_{bm} + V_{bmSD1-top} - V_{bmSD1-bot}$
H_{SD1}	-81.9152 kips	Horizontal component of brace design axial loads
H_{bcSD1}	-107.3268 kips	Beam/column horizontal load per AISC 14th, page 13-5 = $P_{bm-SD1} + (H_{SD1} - (H_{bmSD1-top} + H_{bmSD1-bot}))$

Governing Design Forces

Finally, the governing design forces at each sub-connection interface are reported in the **Seismic Load Distribution Calc. (Governing)** on the **Seismic** tab of the results report. The controlling case is reported in the description on the right. As you can see from this procedure, the governing loads at each interface do not necessarily all come from the same load combination (for integrated models) or even directional load case.

These are the same forces that you will see reported in the yellow box at the top of each sub-interface tab in the results report.

Seismic Load Distribution (Governing)			n/a
Top Gusset/Column Connection:			
Shear (Compression)	24.6856 kips	<i>Maximum compressive shear force (loading direction SD2 governs)</i>	
Axial (Compression)	25.4116 kips	<i>Maximum compressive axial force (loading direction SD2 governs)</i>	
Shear (Tension)	-24.6856 kips	<i>Maximum tension shear force (loading direction SD1 governs)</i>	
Axial (Tension)	-25.4116 kips	<i>Maximum tension axial force (loading direction SD1 governs)</i>	
Resultant force	35.4278 kips	<i>Maximum resultant shear force (loading direction SD1 governs)</i>	
Moment	0.0000 kips-in	<i>Maximum moment (loading direction SD1 governs)</i>	
Top Gusset/Beam Connection:			
Shear (Compression)	56.5036 kips	<i>Maximum compressive shear force (loading direction SD2 governs)</i>	
Axial (Compression)	32.6721 kips	<i>Maximum compressive axial force (loading direction SD2 governs)</i>	
Shear (Tension)	-56.5036 kips	<i>Maximum tension shear force (loading direction SD1 governs)</i>	
Axial (Tension)	-32.6721 kips	<i>Maximum tension axial force (loading direction SD1 governs)</i>	
Resultant force	65.2696 kips	<i>Maximum resultant shear force (loading direction SD1 governs)</i>	
Moment	0.0000 kips-in	<i>Maximum moment (loading direction SD1 governs)</i>	
Beam/Column Connection:			
Shear (Compression)	112.6721 kips	<i>Maximum compressive shear force (loading direction SD2 governs)</i>	
Axial (Compression)	107.3268 kips	<i>Maximum compressive axial force (loading direction SD2 governs)</i>	
Shear (Tension)	0.0000 kips	<i>Maximum tension shear force (no tension force)</i>	
Axial (Tension)	-107.3268 kips	<i>Maximum tension axial force (loading direction SD1 governs)</i>	
Resultant force	155.6086 kips	<i>Maximum resultant shear force (loading direction SD2 governs)</i>	



Connection 1

Vertical Brace Diagonal Connection

Beam/Column connection

LRFD

Material Properties:				
Beam	W18x50	A992	$F_y = 50.0000$ ksi	$F_u = 65.0000$ ksi
Column	W14x90	A992	$F_y = 50.0000$ ksi	$F_u = 65.0000$ ksi
Beam-Col Angle	L4x4x12	A36	$F_y = 36.0000$ ksi	$F_u = 58.0000$ ksi
Top Brace	LL3.5x3.5x6x6	A36	$F_y = 36.0000$ ksi	$F_u = 58.0000$ ksi
Top Gusset	P0.38x13.60x31.13	A36	$F_y = 36.0000$ ksi	$F_u = 58.0000$ ksi

Input Data:		
Shear(Compression)	112.6721 kips	<i>Calculated Shear due to Compression Brace Loading (SD2)</i>
Axial(Compression)	107.3268 kips	<i>Calculated Axial due to Compression Brace Loading (SD2)</i>
Shear(Tension)	0.0000 kips	<i>Calculated Shear due to Tension Brace Loading</i>
Axial(Tension)	-107.3268 kips	<i>Calculated Axial due to Tension Brace Loading (SD1)</i>
Resultant Force	155.6086 kips	<i>Calculated Maximum Resultant Force due to Brace Loading (SD2)</i>
Top Column Dist	20.0000 in	<i>User Input Top Column Dist</i>
Column Force	50.0000 kips	<i>User Input Column Force</i>
Story Shear	0.0000 kips	<i>User Input Story Shear</i>

Each sub-connection interface is then checked for all limit states (tension and compression) per these governing design loads. If a limit state applies to both tension and compression loading, it will be checked against the largest demand value.

OCBF Connection Strength

AISC Seismic Provisions for Structural Steel Buildings (AISC 341-16) chapter F1 gives the design requirements for designing OCBF seismic brace connections.

Per *AISC 341-16 section F1.6a*, the required design strength of an **OCBF** brace connection shall be the load from the governing overstrength load combination. Per the exception, this does not need to exceed the expected strengths in tension (*section F1.6a(a)*) or the expected strength in compression (*F1.6a(b)*). Exception on oversized holes (*F1.6a(c)*) is not currently considered.

Therefore, in RISACONNECTION, the governing design load (in tension or compression) is calculated as the minimum of the expected strength of the brace and the user-input brace axial load.

These calculations are shown in detail under the **Controlling Load Calculation** check on the Seismic tab of the results report.

SCBF Connection Strength

AISC Seismic Provisions for Structural Steel Buildings (AISC 341-16) chapter F2 gives the design requirements for designing SCBF seismic brace connections.

Per *AISC 341-16 section F2.3*, we are required to consider the following two analyses of the connection:

- i. An analysis in which all braces are assumed to resist forces corresponding to their expected strength in tension or compression.
- ii. An analysis in which all braces in tension are assumed to resist their expected strength and all braces in compression are assumed to resist their expected post-buckling strength. This is taken as 30% of the expected strength in compression.

RISACONNECTION considers these analysis methods in the [load cases](#). The design strength used for each load case is described below.

Design Tensile Strength

Per *AISC 341-16 section F2.6c(1)*, the required tensile strength of a **SCBF** brace connection shall be the expected strength in tension.

Although *AISC 341-16 section F2.6c(1)(b)* says that the required tensile strength may come from the maximum load effect indicated by analysis, RISACONNECTION does not allow input axial loading to override the calculated expected strength in tension per *F2.6c(1)(a)*. This is because the analysis methods specifically stated by the code (see *Commentary to section F2.6c(1)*) are not possible with RISA products. Therefore, the program always designs to the full expected yield strength in tension.

Design Compressive Strength

Per *AISC 341-16 section F2.6c(2)*, the required compressive strength of a **SCBF** brace connection shall be taken as 1.1 times the expected strength in compression for LRFD or (1.1/1.5) times the expected strength in compression for ASD. Therefore, in RISACONNECTION, the governing design compressive load is calculated as the following:

- Method (i) - Based on Expected Brace Strength:
 - $P_{des_ci} = (1.1) * P_{expected}$ (LRFD)
 - $P_{des_ci} = (1.1/1.5) * P_{expected}$ (ASD)
- Method (ii) - Based on Expected Post-Buckling Strength:
 - $P_{des_cii} = (1.1)*(0.3)*P_{expected}$ (LRFD)
 - $P_{des_cil} = (1.1/1.5)*(0.3) * P_{expected}$ (ASD)

These calculations are shown in detail under the **Controlling Load Calculation** check on the Seismic tab of the results report.

Note:

- SCBF Vertical Brace Connections will automatically set the gusset to column and gusset to beam connections to a direct weld. This is necessary in order to properly calculate the geometry of the offset hinge lines for the [Seismic Gusset Rotation Capacity/Clearance](#) check.

Additional Considerations of Seismic Brace Force Distribution

In addition to the procedures and provisions listed above, the following assumptions are considered when checking seismic vertical brace connections.

Connections with One Brace (Above or Below)

For diagonal brace connections where there is only one brace (either above or below), the program will calculate the controlling brace design force in tension and the controlling brace design force in compression.

Then, the program will calculate the associated forces at each sub-connection interface. This is done considering multiple loading cases to account for the various combinations of possible loading on the connection. Please see the [chart](#) above for a detailed description of the various directional load cases that RISACONNECTION will consider.

The sub-connection limit states will then be checked against the governing tension and compression forces from each of the possible loading cases.

Note:

- For limit states that apply to both tension and compression loading, the governing (maximum) value will be considered.
- Some limit states are compared to the resultant of the sub-interface shear and axial load. In these cases, a resultant value is considered per directional load case. This is to ensure that the resultant is a realistic combination (i.e. V & P loads are from the same load case).

The screenshot displays the 'Connection View for M5 I' window. The interface includes a menu bar with options: Summary, Beam/Column, Bot Gusset/Beam, Bot Gusset/Col, Bot Gusset/Brace, Seismic, Members, and Components. On the left, there are view controls for 3D View, 2D View, and Reports. The main area shows the RISACONNECTION logo and the title 'M5 I ASD'. Below the logo, it specifies 'Vertical Brace Diagonal Connection' and 'Bottom Gusset/Column connection'. A table lists material properties for various components, and another table lists input data for shear, axial, and resultant forces.

Material Properties:			
Beam	W14x74	A992	F _y = 50.0000 ksi F _u = 65.0000 ksi
Column	W12x120	A992	F _y = 50.0000 ksi F _u = 65.0000 ksi
Beam-Col Angle	L4x4x12	A36	F _y = 36.0000 ksi F _u = 58.0000 ksi
Bottom Brace	L5x5x8	A36 Gr.36	F _y = 36.0000 ksi F _u = 58.0000 ksi
Bottom Gusset	P0.38x14.52x20.37	A36	F _y = 36.0000 ksi F _u = 58.0000 ksi
Bottom Gusset Col Angle	L4x4x12	A913 Gr.65	F _y = 65.0000 ksi F _u = 80.0000 ksi

Input Data:		
Shear(Compression)	8.8265 kips	Calculated Shear due to Compression Brace Loading
Axial(Compression)	7.9615 kips	Calculated Axial due to Compression Brace Loading
Shear(Tension)	-10.4821 kips	Calculated Shear due to Tension Brace Loading
Axial(Tension)	-9.4548 kips	Calculated Axial due to Tension Brace Loading
Resultant Force	14.1162 kips	Calculated Maximum Resultant Force due to Brace Loading
Moment Load	0.0000 kips-ft	Calculated Maximum Moment

Connection with Braces Above and Below

For brace connections with two braces (either chevron connections, or diagonal braces with two brace members) the program will calculate the controlling brace design force in tension and the controlling brace design force in compression for each brace.

Then, the program will calculate the associated forces at each sub-connection interface. This is done considering multiple loading cases to account for the various combinations of possible loading on the connection. Please see the [chart](#) above for a detailed description of the various directional load cases that RISACONNECTION will consider.

The sub-connection limit states will then be checked against the governing tension and compression forces from each of the possible loading cases.

Note:

- When calculating forces at the *Beam to Column* sub-connection interface in a vertical diagonal brace, the program considers the beam axial and shear forces as part of the summation. Due to the procedure described above, the seismic beam axial force will vary depending on the seismic load case being considered. Therefore, the user-entered **Beam Axial Load** is *not* used in this calculation. We cannot rely on the user-input **Beam Axial Load** because it does not correspond to the lateral-only load cases. Instead, RISACONNECTION utilizes an approximate method to derive this force from the *AISC Seismic Design Manual example 5.3.5* (see page 5-158). Please see the [Story Force](#) topic below for details on how we calculate these forces and what assumptions are made.
- The user-input **Beam Shear Load** is used in the Beam to Column interaction forces. Per *AISC Seismic Design Manual example 5.3.5* (see page 5-158), the required shear comes from the gravity loading cases, so it will not vary with the seismic load cases.

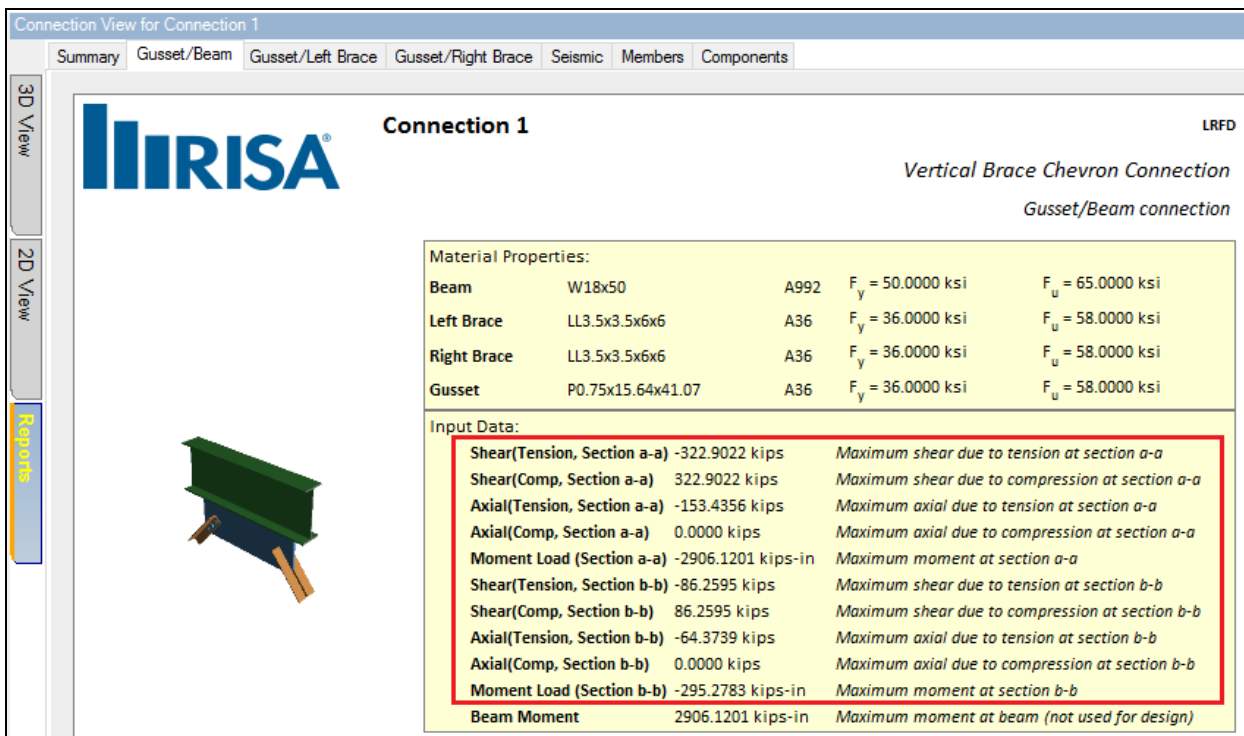

Connection View for Connection 1

Summary Gusset/Beam Gusset/Left Brace Gusset/Right Brace Seismic Members Components

RISA Connection 1 LRFD

Vertical Brace Chevron Connection
Gusset/Beam connection

Material Properties:				
Beam	W18x50	A992	$F_y = 50.0000$ ksi	$F_u = 65.0000$ ksi
Left Brace	LL3.5x3.5x6x6	A36	$F_y = 36.0000$ ksi	$F_u = 58.0000$ ksi
Right Brace	LL3.5x3.5x6x6	A36	$F_y = 36.0000$ ksi	$F_u = 58.0000$ ksi
Gusset	P0.75x15.64x41.07	A36	$F_y = 36.0000$ ksi	$F_u = 58.0000$ ksi

Input Data:		
Shear(Tension, Section a-a)	-322.9022 kips	Maximum shear due to tension at section a-a
Shear(Comp, Section a-a)	322.9022 kips	Maximum shear due to compression at section a-a
Axial(Tension, Section a-a)	-153.4356 kips	Maximum axial due to tension at section a-a
Axial(Comp, Section a-a)	0.0000 kips	Maximum axial due to compression at section a-a
Moment Load (Section a-a)	-2906.1201 kips-in	Maximum moment at section a-a
Shear(Tension, Section b-b)	-86.2595 kips	Maximum shear due to tension at section b-b
Shear(Comp, Section b-b)	86.2595 kips	Maximum shear due to compression at section b-b
Axial(Tension, Section b-b)	-64.3739 kips	Maximum axial due to tension at section b-b
Axial(Comp, Section b-b)	0.0000 kips	Maximum axial due to compression at section b-b
Moment Load (Section b-b)	-295.2783 kips-in	Maximum moment at section b-b
Beam Moment	2906.1201 kips-in	Maximum moment at beam (not used for design)

Story Force Calculations

When calculating forces at the *Beam to Column* sub-connection interface in a vertical diagonal brace, the program considers the beam axial and shear forces as part of the summation. Due to the fact that RISACONNECTION is running multiple load cases of possible loading, we cannot rely on the user-input **Beam Axial Load** for this calculation. Therefore, RISACONNECTION utilizes an approximate method used in *AISC Seismic Design Manual example 5.3.5* (see page 5-158).

This method assumes that the connection is part of a frame which has an equal and opposite connection across from it. Using the brace forces calculated in the [Controlling Load Calculation](#), RISACONNECTION will calculate the

beam axial force at the connection as half of the Story Force in the frame. The details of this calculation are included in the [Seismic Load Distribution Calc.](#) for each directional load case.

Note:

- This only applies to vertical diagonal brace connections.

The calculation is based on simple geometry. Details for each case are shown below.

Single Brace Member

$$Story\ Force = (P_{expected} - P_{opposite}) * \sin\theta$$

$$P_{beam} = 0.5 * Story\ Force$$

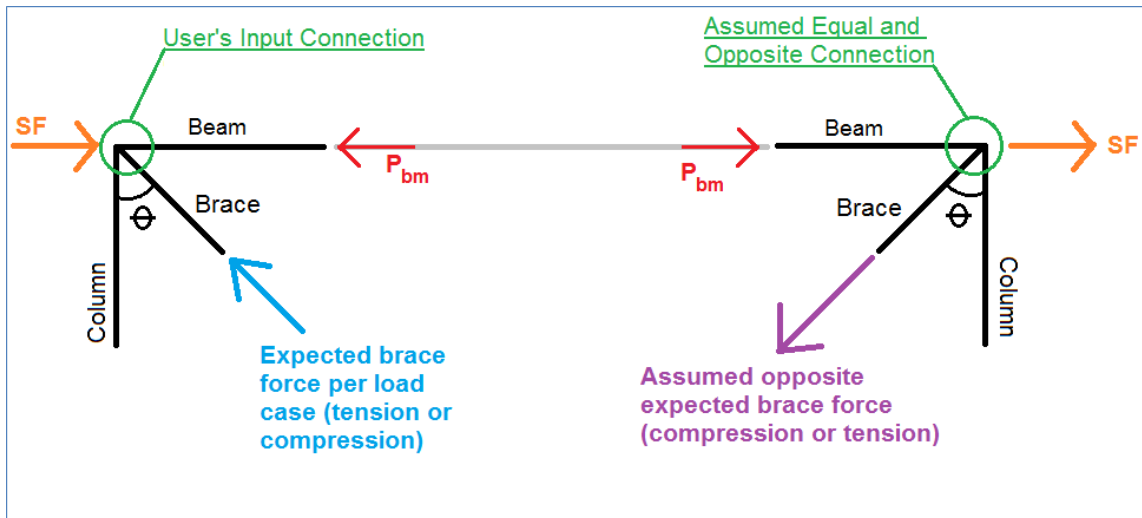

Two Brace Members

$$Story\ Force = (P_{expected_top} - P_{opposite_top}) * \sin\theta_{top} + (P_{expected_bottom} - P_{opposite_bottom}) * \sin\theta_{bottom}$$

$$P_{beam} = 0.5 * Story\ Force$$

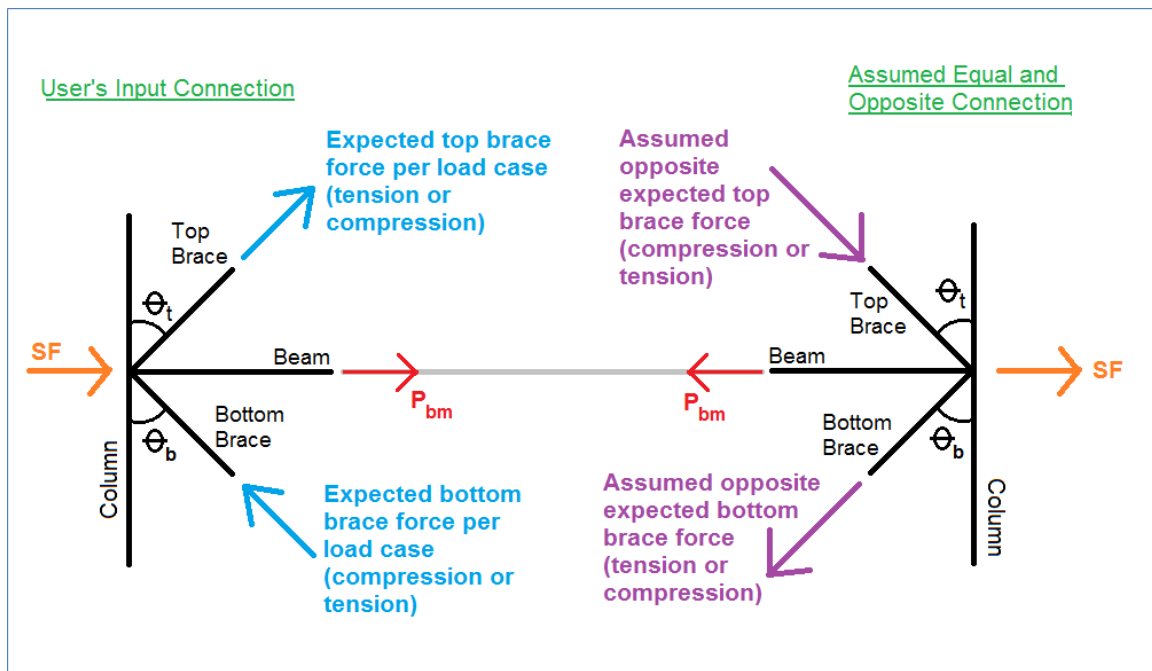

Seismic Vertical Brace Checks

After the governing forces are determined, using the methods discussed above, the governing forces will be reported on each sub-connection tab of the results report.

Connection View for Connection 1

Summary Beam/Column Top Gusset/Beam **Top Gusset/Col** Top Gusset/Brace Seismic Members Components

IRISA Connection 1 LRFD

Vertical Brace Diagonal Connection
Top Gusset/Column connection

Material Properties:				
Beam	W18x50	A992	$F_y = 50.000$ ksi	$F_u = 65.000$ ksi
Column	W14x90	A992	$F_y = 50.000$ ksi	$F_u = 65.000$ ksi
Beam-Col Angle	L4x3.5x6	A36	$F_y = 36.000$ ksi	$F_u = 58.000$ ksi
Top Brace	L6x4x10	A36	$F_y = 36.000$ ksi	$F_u = 58.000$ ksi
Top Gusset	P0.38x13.60x31.13	A36	$F_y = 36.000$ ksi	$F_u = 58.000$ ksi

Input Data:		
Shear(Compression)	40.573 kips	Calculated Shear due to Compression Brace Loading
Axial(Compression)	41.766 kips	Calculated Axial due to Compression Brace Loading
Shear(Tension)	-24.686 kips	Calculated Shear due to Tension Brace Loading
Axial(Tension)	-25.412 kips	Calculated Axial due to Tension Brace Loading
Resultant Force	58.229 kips	Calculated Maximum Resultant Force due to Brace Loading
Moment Load	0.000 kips-in	Calculated Maximum Moment

Because seismic vertical braces design for both tension and compression forces, the resulting limit states will include both tension and compression checks. If any check is designed for both tension and compression loading, the limit state will be checked against the maximum calculated load.

Notes:

- SCBF connections are designed to provide significant inelastic deformation capacity through brace buckling and brace yielding. Therefore, the design the columns, beams, and connection elements to the governing expected brace strength in compression and tension (see *AISC 341-16 section F2.6c*). However, the braces

themselves are designed to the input loads (assumed to be your static load combination analysis results). This means that if your input Brace Tensile Axial load is set to zero, the Brace Tensile Yield and Brace Tensile Rupture limit states will be omitted.

Seismic Tab

The following seismic checks are included on the Seismic tab of the report.

Controlling Load Calculation-

This "check" presents the details of the calculations which determine the [brace design forces](#).

Seismic Loading Directions-

This "check" presents the details of the appropriate [loading directions](#).

Seismic Load Distribution Calculations (Loading Direction XX) -

This "check" presents the details of load distribution per the brace design loading direction XX.

Seismic Load Distribution Calculations (Governing) -

This "check" presents the governing loads at each sub-connection interface per all applicable loading directions.

Seismic Joint Fasteners-

This check ensures the code requirements in *AISC 341-16 section D2.2(b)* which says that "bolts and welds shall not be designed to share force in a joint". OCBF and SCBF vertical diagonal brace connections must have either all bolted or all welded connections.

Seismic Workpoint Limitations-

This check verifies that the connection is a concentric brace connection by limiting the workpoint eccentricity to an arbitrary threshold of $d_{\text{beam}}/10$. If the workpoint eccentricity exceeds this limit, the check will fail which means the connection does not meet the requirements of *AISC 341-16 section F1.2 or F2.2* which says that seismic brace design is only applicable to concentric vertical brace connections.

Seismic Yield Stress Limitations -

This check includes material geometry limits from the *AISC 341-16 section A3.1*.

Seismic Brace Slenderness-

This check includes slenderness limits from the *AISC 341-16 section F1* for OCBF and *section F2.5b* for SCBF.

Seismic Width to Thickness Ratios-

This check includes width to thickness ratio checks per *AISC 341-16, Table D1.1*.

Check Seismic Brace Area-

This check is only applicable to SCBF braces that are slotted over the gusset plate. The check calculates the amount of additional reinforcement that must be added to the brace in order to ensure that the brace has significant strength to resist the high expected loads (see *AISC 341-16 section F2.5b(c)*). The calculation procedure is based on that found in example 5.3.8 of the *AISC Seismic Design Manual* (page 5-232).

At this time, the program only reports the amount of reinforcement that must be added. A later version will include the option to add reinforcing bars to the connection.

Seismic Rotational Ductility-

This check includes plate thickness check per *AISC 341-16 section F2.6b(a)* which accounts for the check against rotational ductility requirements. Page 5-122 of the *AISC Seismic Design Manual* says that simple connections per Part 10 of the *AISC Steel Design Manual* meet this requirement. Therefore, this check is done to the requirements of Part 10. This is only applicable to SCBF connections.

Seismic Gusset Rotation Capacity/Clearance-

Per the User Note in *AISC 341-16 section F2.6c(3)(b)*, accommodation of inelastic rotation is typically accomplished by terminating the brace before the line of restraint. The commentary on this section suggests a $2t$ linear offset. This check includes verification of this suggested geometry. This is only applicable to SCBF connections.

Page 5-338 of the *AISC Seismic Design Manual* (and many other technical references) suggest using an elliptical line on vertical brace connections to achieve a more compact gusset plate. Instead of the **2*tp Linear** option, you may select the **8*tp Elliptical** method for SCBF vertical brace connections. This option is available with the [Seismic Input](#) parameters.

Note:

- When you select a SCBF vertical brace connection, the program automatically sets your gusset to column and gusset to beam connections to direct weld. No bolted clip angles are allowed. This limitation is required in order for the program to correctly calculate the offset hinge lines for the **Seismic Gusset Rotation Capacity/Clearance** check.

2t Linear Limit

RISACONNECTION checks to make sure that the hinge line distance is between $2*tp$ (the lower limit suggested by the AISC 360-16) and $4*tp$ (an upper limit suggested in the Steel Tips article "*Seismic Detailing of Gusset Plates for Special Concentrically Braced Frames*" by Astaneh-Asl, Cochran, and Sabelli).

8t Elliptical Limit

When the 8t Elliptical option is selected, this limit state will check to verify that the hinge line distance is $8*t_{gusset}$ or greater from the elliptical hinge line.

Note:

- The 8t Elliptical Offset option is not available for tapered gusset plates.

Graphical View of the Hinge Line

The hinge line will be displayed in yellow on the 2D View of the connection.

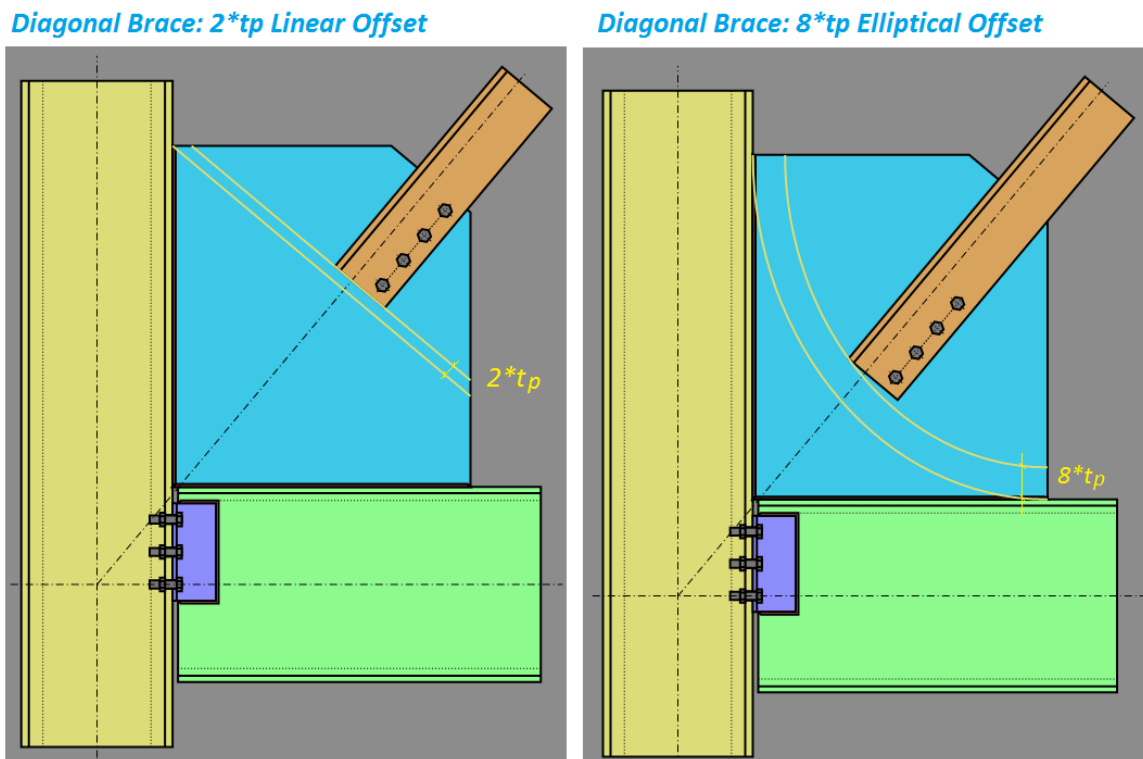

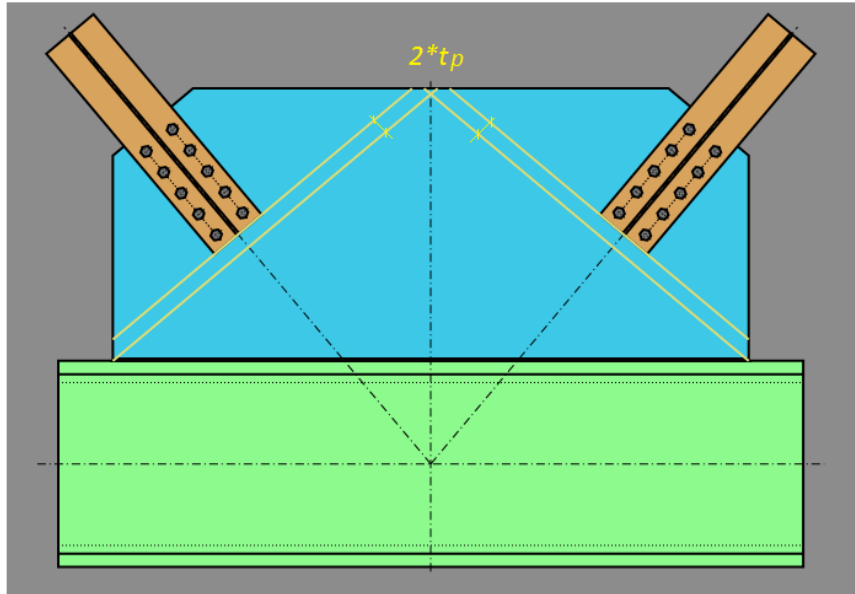
Chevron Brace: 2*tp Linear Offset**Seismic Weld Strength-**

Per page 5-357 of the *AISC Seismic Design Manual*, interface welds at the gusset to beam and gusset to column connections should be designed for the expected tensile strength of the gusset plate. Therefore the Required load for this check will always be equal to $R_y * F_y * t_{plate}$. This is only applicable to SCBF connections.

Seismic Detailing DXF Output

In addition to the regular DXF output, the seismic connections will include:

- Identification of the seismic system.

Base Plate Connections

The program includes two kinds of Base Plate Connections:

- Column Base Plate
- Brace to Column Base Plate

The **Column Base Plate** connection is a rectangular steel plate welded to the bottom of a steel column. The steel plate sits on the top of a concrete support without a grout pad between. The plate is bolted to the concrete with headed bolts that are embedded in the concrete. Options for modeling and designing these connections are described below.

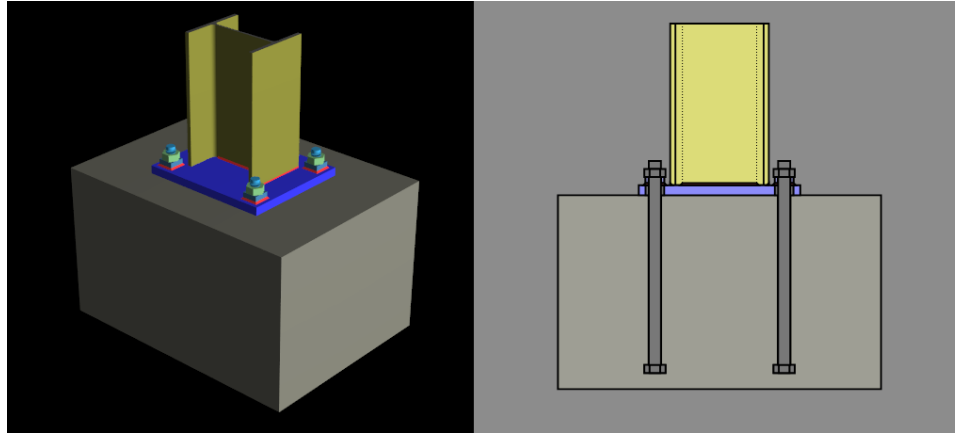

In addition to designing base plates, RISACONNECTION now offers comprehensive solutions for full anchorage design. This new feature encompasses the detailed analysis and design of anchor rods to the supporting concrete pedestal. Note that anchorage design is available exclusively when the Steel Code is configured to LRFD.

The **Brace into Column Base Plate** connection is the same as the Base Plate connection above with a vertical brace gusset framing into either the column web or flange. Options for modeling and designing these connections are described below.

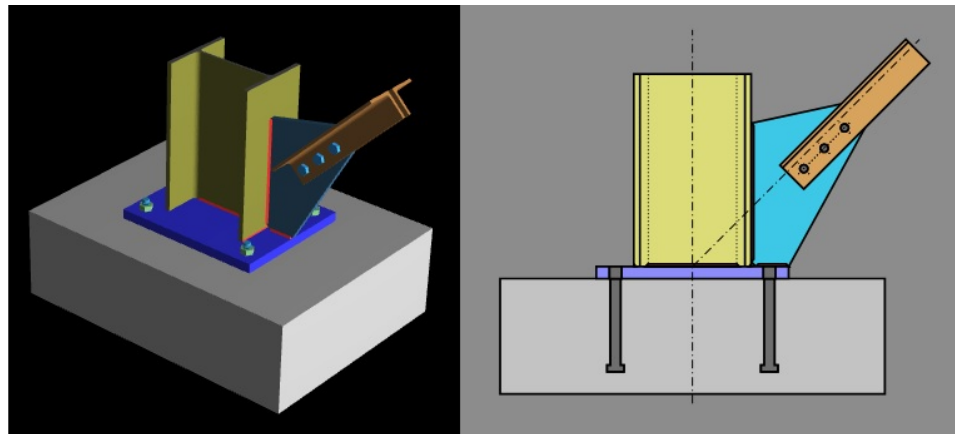

Anchorage design is not available for the **Brace into Column Base Plate** connection module.

How to Create a Base Plate Connection

Starting from Scratch in the Stand-Alone Version

If you are using RISACONNECTION as a stand-alone program, then you can define a Base Plate connection as follows:

1. Start a new model and select the Base Plate connection type.

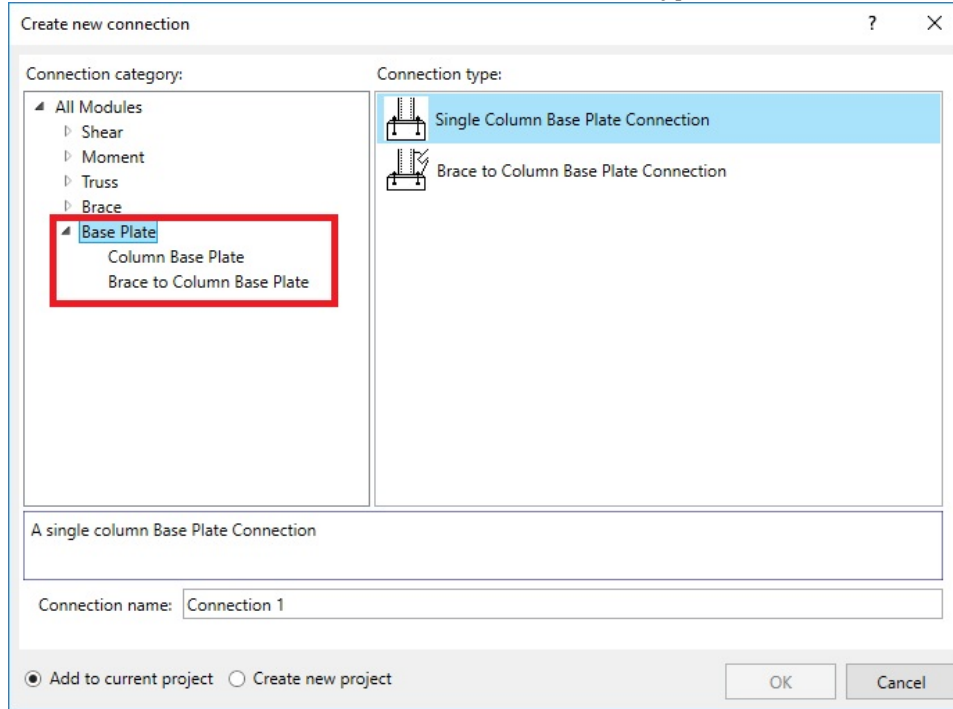

2. Enter the appropriate input to define the [geometry and connection details](#).
3. Click on the **Reports** tab to view the design **Results**.

Importing a Connection from a RISA-3D Model

If you are using RISACONNECTION integration with RISA-3D, then you can define a base plate connection as follows:

1. Create a base plate **Connection Rule** and apply it to the bottom end of your column member in RISA-3D. See the RISA-3D Help menu for more assistance with this.

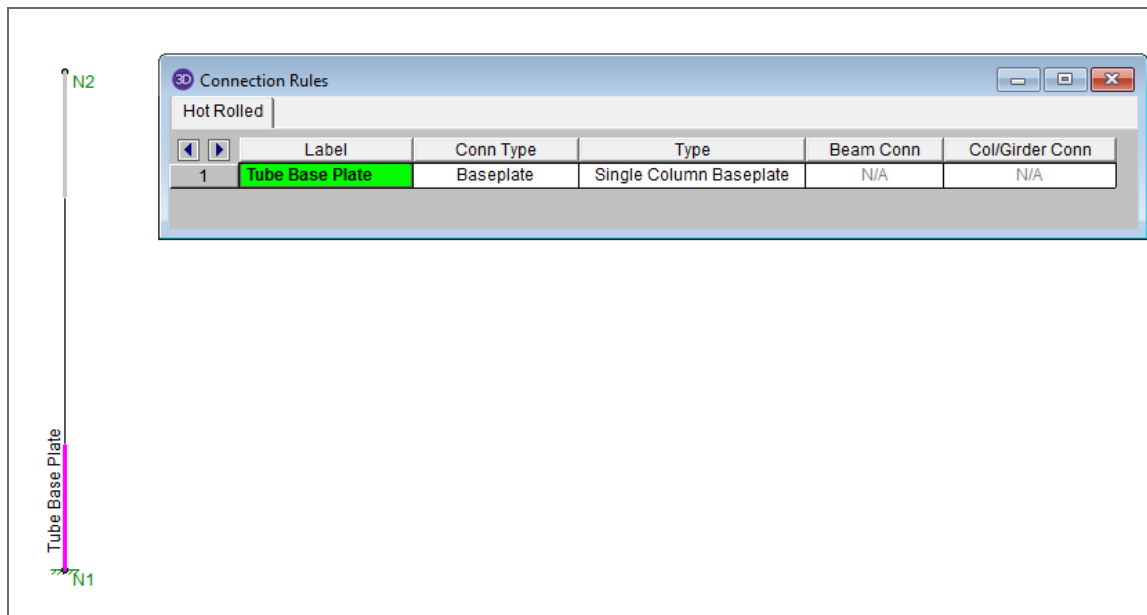

2. Solve your RISA-3D model then use the **Director** tool to export to RISACONNECTION.
3. When exported into RISACONNECTION, the program will determine the **Connection Type, Base plate Fixity,** loading, and member sizes based on the RISA-3D solution results. Once in RISACONNECTION, these cannot be changed.

Importing a Connection from a RISAFloor Model

If you are using RISACONNECTION integration with RISAFloor, then you can define a base plate connection as follows:

1. Create a Base Plate **Connection Rule** and apply it as the **Splice Connection** at the bottom-most floor level in RISAFloor. See the RISAFloor Help menu for more assistance with this.

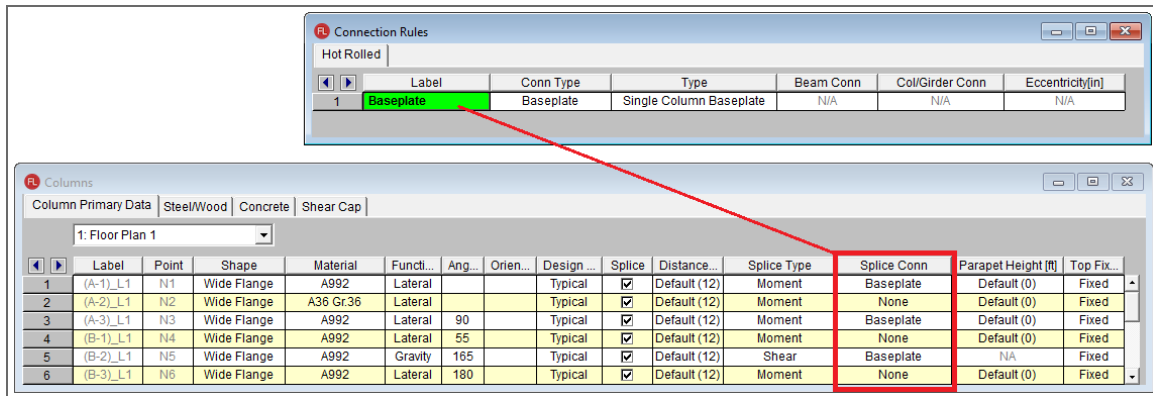

2. Solve your RISAFloor model then use the **Director** tool to export to RISACONNECTION.
3. When exported into RISACONNECTION, the program will determine the **Connection Type, Baseplate Fixity,** loading, and member sizes based on the RISAFloor solution results. Once in RISACONNECTION, these cannot be changed.

Limitations- Base Plate Connections

Below is a list of limitations for Base Plate design:

- Currently base plate connection design is only supported for US codes (AISC 360-05, AISC 360-10, and AISC 360-16).
- The steel column must be a Wide Flange, Tube, or Pipe shape type.
- Braces must be HSS Tube, HSS Pipe, Channel, WT, Double Angle, or Single Angle sections.
- The column must be centered on the base plate.
- The base plate must be centered on the concrete support.
- The base plate must be rectangular.
- The concrete support must be rectangular and may not be smaller than the steel base plate.
- The self-weight of the base plate and the anchor bolts are ignored.
- No seismic design is done at this time.

Below is a list of limitations for the Anchorage Design:

- Currently anchorage connection design is only supported for US codes (ACI 318-19 & ACI 318-19 (22)).
- Currently available bolt configurations are restricted to four, six, and eight bolts. Custom layout of anchor bolts are not currently supported.
- Applicable solely to single column base plate; Columns with bracing are not supported presently.
- Seismic design checks are excluded from the current analysis.
- Anchor bolt design is confined to cast-in-place anchors only.
- Defining load combinations within RISACONNECTION is not available in the standalone version of the program.

- Anchorage checks are conducted for each direction independently and does not account for interaction effects.

Input Properties

The following inputs are available to define your Base Plate connection:

Gusset to Column Orientation

This entry is only applicable for the **Brace to Column Base Plate Connection** type. It controls which side of the column the brace/gusset frames into (web or flange).

Brace Location

This entry is only applicable for the **Brace to Column Base Plate Connection** type. It controls which side of the column the brace/gusset attaches to. This is important for connections with singly-symmetric anchor bolt layouts.

Anchorage Type

This setting determines the anchorage type applied in the analysis. As of the current version, the software supports exclusively cast-in-place anchors for this functionality.

Anchor Reinforcement

This setting indicates whether supplemental reinforcement has been specifically detailed by the engineer to transfer anchor loads into the foundation in accordance with ACI 318-19 Section 17.5.2.1 (e.g., hairpins, stirrups, or hook bars developed into the footing). When set to Yes, the directional reinforcement options below become available. RISACONNECTION does not design or check the supplemental reinforcement; the engineer is responsible for detailing this reinforcement to satisfy ACI 318-19 Section 17.5.2.1.

Anchor Reinforcement - Shear

When set to Yes, the user is indicating that reinforcement has been provided to transfer anchor shear into the foundation per ACI 318-19 Section 17.5.2.1. In this case, concrete breakout in shear limit states (Strong Axis and Weak Axis) are bypassed and reported as n/a (not applicable) in the anchorage design report.

Anchor Reinforcement - Tension

When set to Yes, the user is indicating that reinforcement has been provided to transfer anchor tension into the foundation per ACI 318-19 Section 17.5.2.1. In this case, concrete breakout in tension and anchor-group breakout in tension limit states (Strong Axis and Weak Axis) are bypassed and reported as n/a (not applicable) in the anchorage design report.

Bolt Layouts

The following bolt layouts are currently available:

- **Four** - This option defaults to one bolt at each corner of the plate.

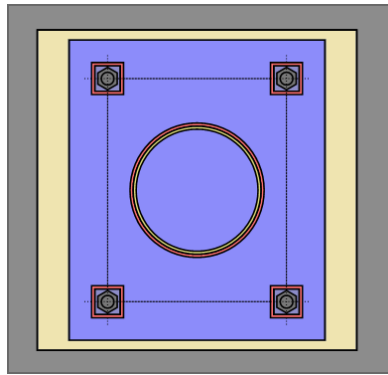

- **Six** - This option defaults to three bolts on two opposite sides of the plate. The user can indicate whether the bolts go on the "Strong Axis" or "Weak Axis" using the Layout Option entry.

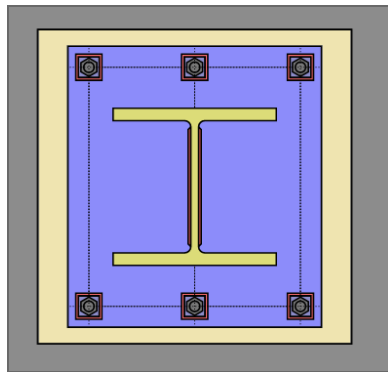

- **Eight** - This option defaults the eight bolts equally around each side of the plate.

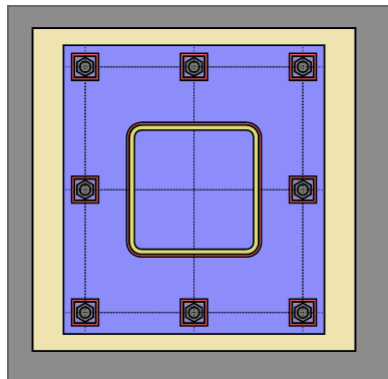

- **Custom** - This option allows you to create a custom anchor bolt layout where the program can perform calculations up to 18 bolts.

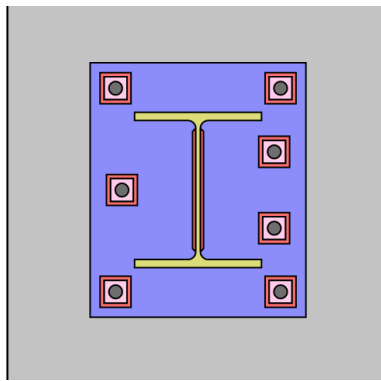

Accessing the Custom Bolt Layout Editor

After setting the Bolt Layout to 'Custom' You can access the custom bolt layout by either double clicking the anchor bolts in the graphical interface or clicking the triple dots within the <Bolts Coordinates...> cell in the Anchors input. Custom anchor layouts are currently not supported for anchorage calculations.

	Z [in]	Y [in]
1	6.500	-8.000
2	-6.500	-8.000
3	6.500	8.000
4	-6.500	8.000

Anchor Bolts	1" F1554 Gr.36-N
Material	F1554 Gr.36-N
Diameter, in.	1"
Anchors	<Bolts Coordinates...>
Flange Weld	F70

Connection Properties	
Connection	
Connection Title	Connection 1
Connection Type	Single Column Base Plate Connection
Anchorage	
Anchorage Type	Cast-in-place
Connection Category	
Bolt Layout	Custom
Plate Washers	No
Loading (LRFD)	
Axial, kips.	100.000
Strong Axis Shear, kips.	10.000
Weak Axis Shear, kips.	0.000
Strong Axis Moment, kips-ft.	8.333
Weak Axis Moment, kips-ft.	0.000
Components	
> Column Section	W12X58
> Base Plate	P1.25x17.00x20.00
> Concrete Support	C40.00x30.00x12.00
> Anchor Bolts	1" F1554 Gr.36-N
Material	F1554 Gr.36-N
Head Type	Hex Bolt
Torque Type	Untorqued Anchor
Diameter, in.	1"
Embedment depth, in.	9.000
Anchors	<Bolts Coordinates...>
> Flange Weld	E70
> Web Weld	E70

Custom Bolt Layout Editor Functionality

Within the custom anchor bolt layout editor, you can perform several basic functions to customize your anchor bolt layout.

Selection

You can use the cursor to graphically click and select any of the displayed bolts. The corresponding anchor bolt coordinates will be highlighted in the Anchor Bolt Coordinates table to the right. Similarly, you can click and select a bolt from within the coordinates table on the right and the corresponding bolt will be selected in the graphical view.

Custom Anchor Bolt Layout Editor

	Z [in]	Y [in]
1	6.000	-8.000
2	2.000	-8.000
3	-2.000	-8.000
4	-6.000	-8.000
5	6.000	8.000
6	2.000	8.000
7	-2.000	8.000
8	-6.000	8.000
9	6.000	0.000
10	-6.000	0.000



Anchor Bolt Coordinates

OK Cancel

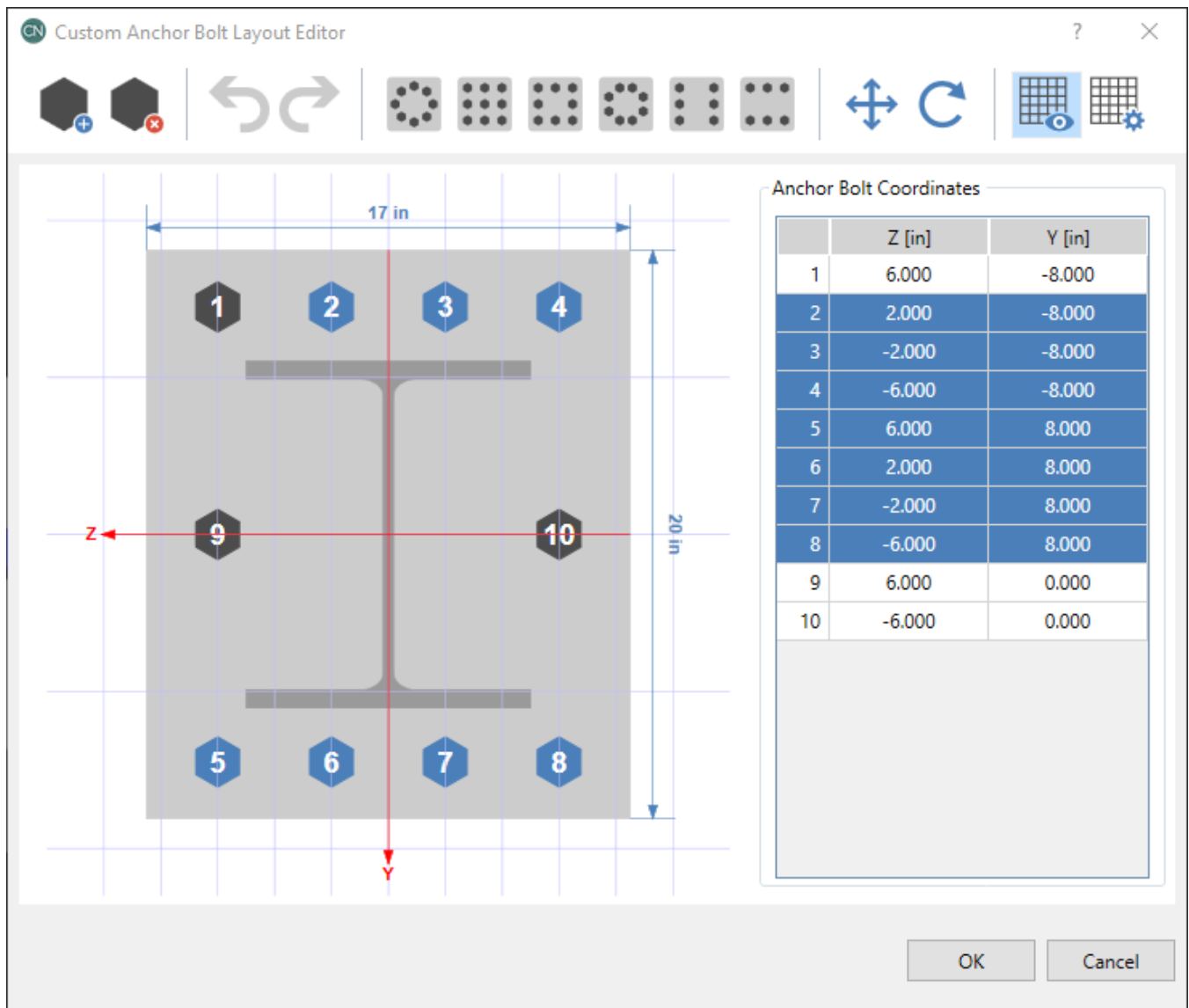

You can also select multiple bolts by holding the Ctrl key and selecting several bolts within the graphical view and/or coordinates table. If you have a bolt selected and hold the Shift key and select another bolt, all the bolts chronologically in between will also be selected. For example, in the example below, if you have bolt #2 selected, hold the shift key and select bolt #8 (graphically or in the coordinate table) all the bolts in between will be selected.









Add/Delete Bolts

Use the   buttons to add or remove anchor bolts.

Undo/Redo

Use the   buttons to undo or redo changes made within the custom anchor bolt layout editor.

Anchor Bolt Template Generators

Use the       buttons to access anchor bolt templates that will allow you to quickly generate anchor bolts in various layouts.

Move/Rotate Bolts



Use the buttons to move or rotate the anchor bolts.

Drawing Grid

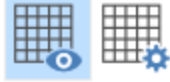

Use the buttons to toggle the display of the drawing grid and custom the increments of the drawing grid.

Grout Pad

This option allows you to specify if a grout pad is present between the base plate and the concrete support.

Yes/No - Select **Yes** to enable grout pad modeling. When **Yes** is selected, the **Grout Thickness** input field becomes available under **Components** --> **Grout Pad** field.

Thickness - Enter the thickness of the grout pad. Maximum allowable thickness is 7.0 inches.

Connection Properties	
Anchor Reinforcement	No
Connection Category	
Bolt Layout	Four
Grout Pad	Yes
Flange Weld	Yes
Plate Washers	No
Loading (LRFD)	
Axial, kips.	100.000
Strong Axis Shear, kips.	10.000
Weak Axis Shear, kips.	0.000
Strong Axis Moment, kips-ft.	8.333
Weak Axis Moment, kips-ft.	0.000
Components	
Column Section	W12X58
Base Plate	P1.25x17.00x20.00
Material	A36
Length, in.	20.000
Width, in.	17.000
Thickness, in.	1.250
Static Friction Coefficient, C	0.450
Hole Type	OVS
Grout Pad	C20.00x17.00x2.00
Length, in.	20.000
Width, in.	17.000
Thickness, in.	2.000
Concrete Support	C40.00x30.00x12.00
Anchor Bolts	1" F1554 Gr.36-N
Flange Weld	E70
Web Weld	E70
Assembly	

Note:

- Selecting **Yes** automatically sets the **Static Friction Coefficient** to 0.45 per AISC Design Guide 1, 3rd Edition, Table D-1 (Note 1).
- This feature is only available for Single Column Base Plate Connections.

Plate Washers

This option allows you to select whether or not washers are present. When present, they will have a fillet weld to the base plate around their entire perimeter.

Loading

The following loading options are available:

Axial - positive magnitude denotes compression, negative magnitude denotes tension.

Strong Axis Shear - Shear load along the weak axis of the column which causes strong axis bending.

Weak Axis Shear - Shear load along the strong axis of the column which causes weak axis bending.

Strong Axis Moment - Moment about the strong axis of the column (only applicable to "Fixed" base plates).

Weak Axis Moment - Moment about the weak axis of the column (only applicable to "Fixed" base plates).

Note:

- Self-weight of the base plate and anchor bolts are ignored because they are relatively insignificant to the applied loading.

Tapered Gusset Plates

This entry is only applicable for the **Brace to Column Base Plate Connection** type. By default brace gusset plates are rectangular, but you may enter tapered dimensions if you prefer to have the gusset plate cut back. To select this, simply set "Tapered" to "Yes" under the Gusset plate entry. The inputs are similar to [those for all vertical braces](#).

▼	Components	
>	Brace Double Angle Section	LL3.5x3.5x6x6
>	Column Section	W12x58
▼	Gusset	P0.75x11.84x16.90
	Material	A36
	Tapered ?	Yes
	Thickness, in.	0.7500
	Width, in.	11.8388
	Length, in.	16.8965
	Cut Width, in.	7.9388
	Cut Length, in.	2.0000
	Gusset to Base Plate Length, in.	3.9000
	Hole Type	STD
>	Base Plate	P1.25x17.00x20.00
>	Concrete Support	C40.00x30.00x12.00
>	Anchor Bolts	1" F1554 Gr.36-N
>	Flange Weld	E70
>	Web Weld	E70

WorkPoint Location

This entry is only applicable for the **Brace to Column Base Plate Connection** type. It controls the position of the brace to column workpoint. This may be moved up and down along the column's center-line, or left to right along the base plate. This effects the calculation of the applied loads at each sub-connection interface per the *AISC Design Guide 29* methodology.

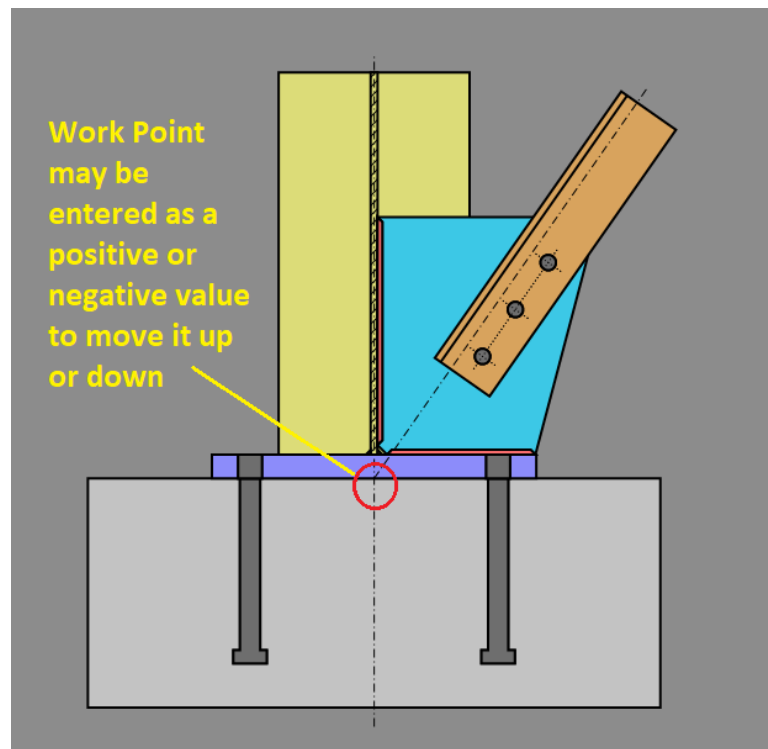

Design Methodology

RISACONNECTION uses a modified version of the design methodology prescribed in *AISC Design Guide 1 (2nd Edition, 2nd Printing)* to design column base plates and anchor rods. The broad concept of this methodology is that yield lines are assumed where plate bending occurs, and the concrete bearing stress is assumed to be uniform at locations outside of those yield lines. The only significant modification to the AISC method is that plate side-bending is also considered (bending of the plate perpendicular to the bending moment applied to the plate). This modification is implemented per the article "Two-Way Bending of Base Plates under Uni-axial Moment Loading - Alternative Approach", published in AISC's *Engineering Journal*, Fourth Quarter 2014 (Volume 51, No. 4).

The base plate and anchor rods are analyzed independently for each bending direction, even if bi-axial moments are applied for the same load combination. This is because there is currently no widely accepted method other than finite element analysis for determining the bearing pressure geometry and the anchor bolt forces under bi-axial bending. Results are presented independently for both bending directions, and it is up to the user to judge what the combined interaction effects would be.

Anchor Bolt Forces and Bearing Length, Y

The anchor bolt forces are determined from a free body diagram currently with the Bearing Length, Y . Using the following geometry, the program solves multiple force equilibrium equations simultaneously to determine the forces in the anchor bolts experiencing tension and the concrete bearing length. The following equations/ figures are an example of this calculation being done for 3 rows of bolts in tension.

$$n_1 T_1 x_1 + n_2 T_2 x_2 + n_3 T_3 x_3 - \frac{1}{2} q_{max_N} Y^2 + P \frac{N}{2} - |M| = 0$$

$$n_1 T_1 + n_2 T_2 + n_3 T_3 + P - q_{max_N} Y = 0$$

$$\frac{T_1}{x_1 - Y} = \frac{T_2}{x_2 - Y}$$

$$\frac{T_1}{x_1 - Y} = \frac{T_3}{x_3 - Y}$$

Where,

- Rows of bolts in tension are numbered starting at the furthest distance from origin
- O = point of origin used for static equilibrium equations
- $T_{(n)}$ = tension caused by row n of bolts.
- $n_{(n)}$ = number of bolts in row n
- $x_{(n)}$ = distance from origin to row n
- q_{maxN} = compression load per unit length along plate edge
- Y = bearing length
- P = vertically applied force
- M = applied bending moment
- N = length of baseplate

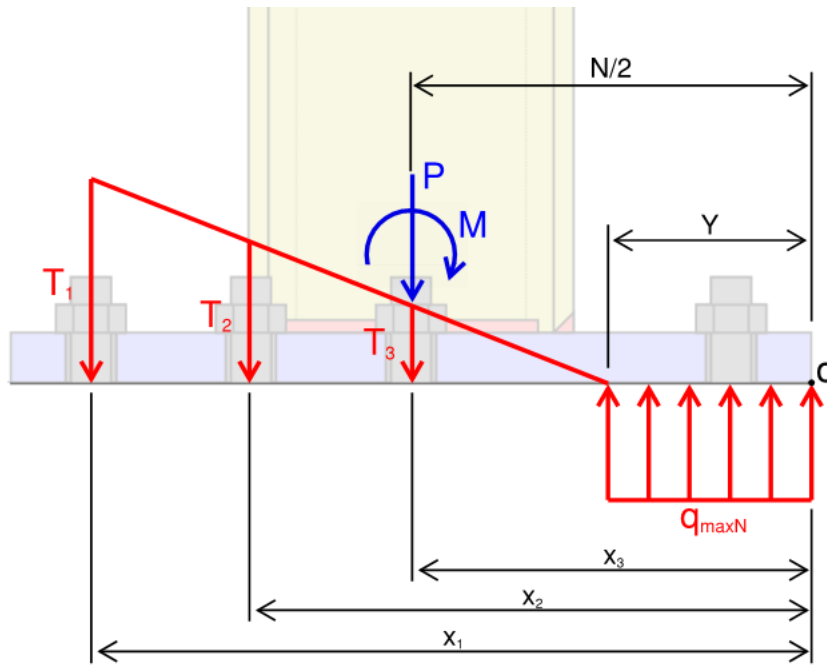

Certain configurations involving large moments and small base plates can make the algebraic equation used to determine the anchor bolt forces unsolvable. When this happens the program does not report forces, and shows the base plate as failing. Even if a solution could be found through more advanced math, the base plate would fail under these conditions anyway, so the plate must be up-sized whenever this happens.

Brace to Base Plate Design

Brace to Column Base Plate connections design the base plate using the same design assumptions as above. Additional checks of the gusset, brace, and interaction between the gusset and the column/plate are per the direction of the *AISC Design Guide 26: Vertical Bracing Connections - Analysis and Design* section 4.3.

The Design Guide methodology assumes:

- Empirical equations are used to determine the load distribution from the brace axial load to the loading on the gusset to base plate and gusset to column interfaces.
- The gusset to base plate is assumed to only resist shear (no axial).
- Similar to the vertical Diagonal Brace Connection, the sub-connections (gusset to brace, gusset to column, gusset to base plate, and column to base plate) are all designed independently per the empirically determined loads.

Limitations:

- Currently, the program only supports one brace connected to the column (web or flange).
- Column stiffeners are not yet available.
- Base Plate extensions are not yet available.

Base Plate Design Checks

Using the methods discussed above the design forces are calculated and then checked against the applicable limit states in the results report.

The following checks are included on the report:

Geometry Restrictions-

This check includes the following material geometry limits:

- **Bolt spacing and edge distance** restrictions come from the *AISC 341-10 section J3*. If you use Extra Oversized ([XOVS](#)) bolt holes, there is not specific code reference for minimum edge distance, so RISACONNECTION uses the following limit:

$$ED_{XOVS} := \left(\frac{D_{XOVS} - D_{OVS}}{2} \right) + ED_{OVS} \quad \text{Min edge distance of an extra-oversize hole}$$

where:

- d = anchor bolt diameter
- D_{OVS} = diameter of an oversize hole (per AISC 360-10 Table J3.3)
- D_{XOVS} = diameter of an extra-oversize hole (per AISC 360-10 Table C-J9.1)
- ED_{OVS} = min edge distance of an oversize hole (per AISC 360-10 Table J3.4)

- **Anchor hole encroachment** checks to make sure that the fillet weld around the column does not overlap the anchor bolt hole. This is a basic geometry check.
- **Plate washer width restriction** from the *AISC 303-10 section 7.5.1*. If you use Extra Oversized ([XOVS](#)) bolt holes, the hole diameter is taken from *AISC 360-10 Table C-J9.1*.
- **Plate washer weld edge distance** checks to make sure that the plate washer fillet weld does not hang over the edge of the base plate. This is interpreted using the "shelf dimension" stipulated in *AISC 360-10 section J2.2b*.

Load Distribution-

This "check" presents the details of the calculation to determine the bearing length of the plate in each the strong and the weak axis directions. This is done per the procedure in *AISC Design Guide 1 (2nd edition, 2nd printing)*. For more information, see the [Design Methodology](#) topic above.

Note:

- This is only applicable to "Fixed" base plate connections.

Concrete Bearing-

This limit state checks the bearing of the steel plate on the concrete support per *ACI 318-14 section 22.8.3.2*. This check includes a **Bearing Stress Increase Factor, α** which is calculated based on the **Effective Concrete Support Length (L')** and **Width (W')** values. L' and W' are calculated based on the following ratios:

$$\alpha := \min \left(2, \sqrt{\frac{A_2}{A_1}} \right)$$

Bearing Stress Increase Factor (per AISC DG1, section 3.1.1)

Where:

B	= Width of base plate
N	= Length of base plate
L	= Length of concrete support
W	= Width of concrete support
A_1	= Area of the base plate = $B \cdot N$
A_2	= Maximum area of the portion of the supporting surface that is geometrically similar and concentric with the loaded area = $L' \cdot W'$
L'	= Effective concrete support length = $N \cdot (B/W)$ when $L/N > W/B$ = L when $L/N < W/B$
W'	= Effective concrete support width = $B \cdot (L/N)$ when $L/N < W/B$ = B when $L/N > W/B$

Note:

- It is possible for the Concrete Bearing unity check to go to exactly 1.0 when you put a large enough moment on the plate to engage some anchor bolts in tension. When this occurs, the zone where the concrete is in compression is assumed to be at a uniform compression stress equal to the capacity. This is similar in theory to the rectangular stress block assumption for concrete beams.

Lateral Slip-

This limit state checks if the friction between the steel plate and the concrete is enough to resist the applied shear. It is only applicable when there is applied shear and when the axial force is in compression (i.e. a positive axial input). If this limit state "fails" then the program will assume all of the shear is resisted by the anchor bolts instead and this check will be replaced by the Anchor Bolt Shear limit state.

Note:

- You may disable this check and thereby force all of the shear to be resisted by the anchor bolts by setting the **Static Friction Coefficient** (under **Base Plate Component** input) to zero.
- When a **Grout Pad** is specified (**Grout Pad = Yes**), the **Static Friction Coefficient** defaults to 0.45 per AISC Design Guide 1, 3rd Edition, Table D-1 (Note 1). This accounts for the reduced tangential friction at the base plate/grout interface.

Plate Flexural Yielding (Compression)-

This limit state checks yielding of the base plate near the compression block. It is checked independently for weak axis and strong axis bending.

For each bending moment on the column the compression block (shown in red below) causes the plate to bend about two axes.

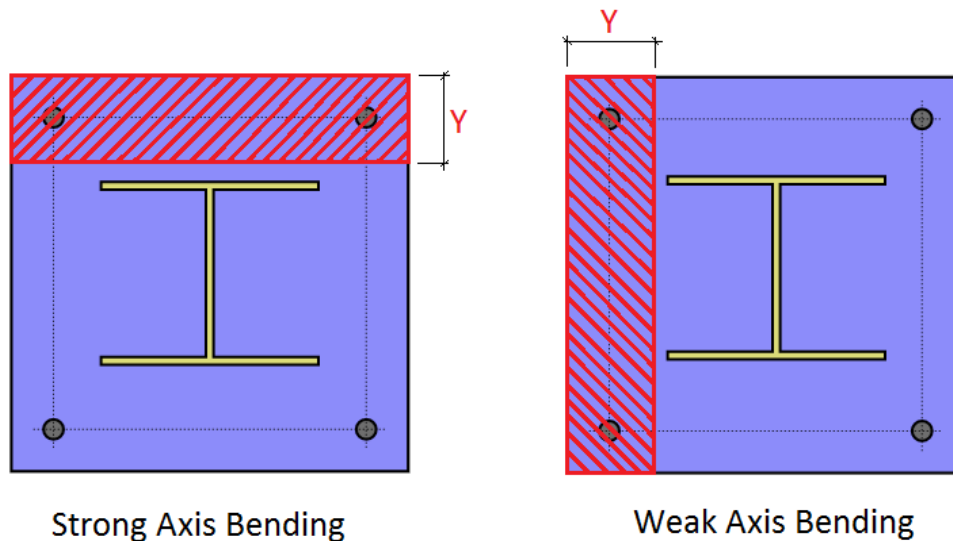

Bending about the 1-1 axis is called "Straight Bending". This bending occurs over the entire length or width of the plate.

Bending about the 2-2 axis is called "Side Bending". This bending occurs only over the length (Y) of the compression block. This bending is occurring outside of each of the 2-2 lines.

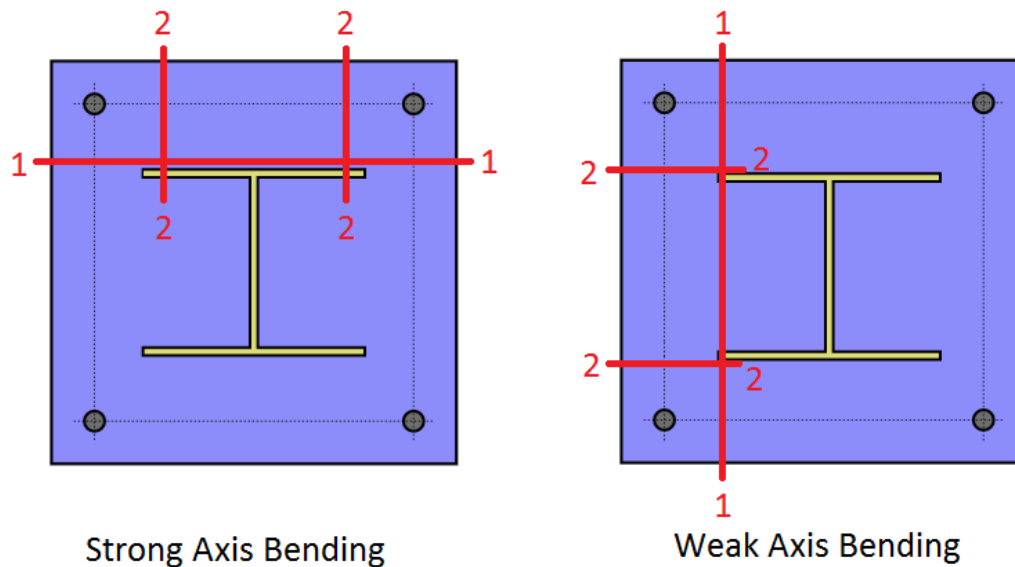

- The Straight Bending check is done per *AISC Design Guide 1 (2nd edition, 2nd printing) sections 3.1.2 and 3.1.3*. The demand moment (M_{pl1}) is equal to the total force in the compression block (beyond the 1-1 line) multiplied by the distance of the centroid of that block to the 1-1 line.
- The Side Bending check is done per the design procedure recommended in the article "Two-Way Bending of Base Plates under Uni-axial Moment Loading - Alternative Approach", published in *AISC's Engineering Journal*, Fourth Quarter 2014 (Volume 51, No. 4). This article recommends using an effective width (b_{eff}) rather than width of the rectangular stress block (Y) to calculate the plate's bending capacity. This is accomplished in RISACONNECTION by multiplying the demand moment (M_{pl2}) by a factor (β). See below for the equations used to calculate Beta (β).

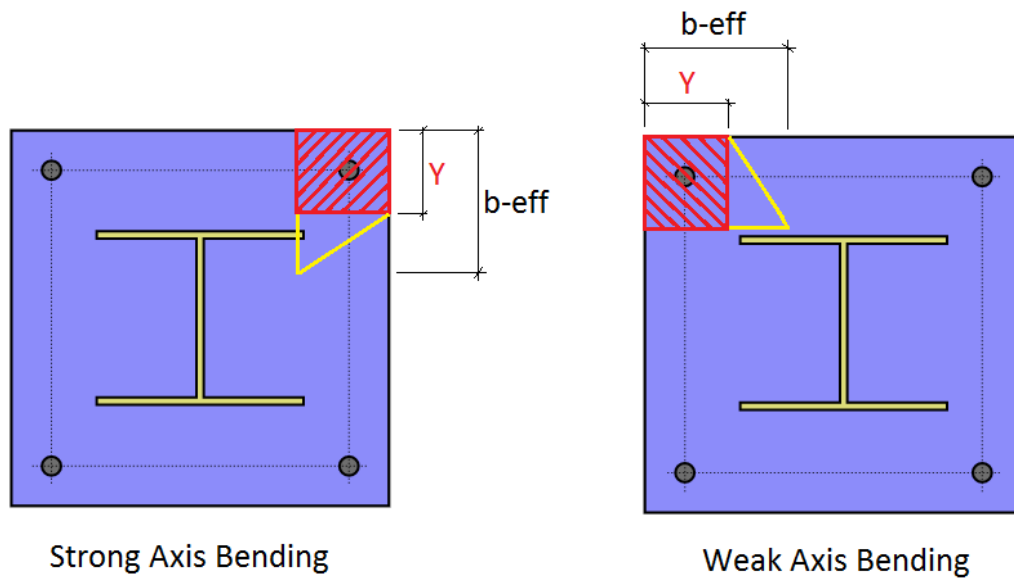

- Beta Factor Calculation:
 - Strong Axis Bending: $\beta = Y/((Y/2)+n)$
 - Weak Axis Bending: $\beta = Y/((Y/2)+m)$

Unity check per the *Engineering Journal* article: $UC_{Article} := \frac{M_{u2}}{M_{n.eff}}$

Unity check per RISACONNECTION: $UC_{RISACONNECTION} := \frac{M_{u2.unit}}{M_{n.unit} \cdot \left(\frac{M_{n.eff}}{M_n} \right)}$

...which rearranges to: $UC_{RISACONNECTION} := \frac{\beta \cdot M_{u2.unit}}{M_{n.unit}}$

with: $\beta := \frac{M_n}{M_{n.eff}}$

Where:

- M_n = Bending capacity using width of "Y" (kip-ft)
- $M_{n.eff}$ = Bending capacity using a width of "b-eff" (kip-ft)
- $M_{n.unit}$ = Bending capacity used by RISACONNECTION (kip-ft per inch width) *Irrespective of plate width*
- M_{u2} = Total design moment across width (kip-ft)
- $M_{u2.unit}$ = Moment used by RISACONNECTION (kip-ft per inch width) *Irrespective of plate width*

The larger of the Straight Bending Moment and the Side Bending Moment (M_{p11} , M_{p12}) is considered to govern, and is compared against a unit width bending capacity of the plate for this check.

Plate Flexural Yielding (Tension)-

This limit state checks the plate bending due to tension in the anchor bolts. The bending moment is calculated as the bolt tension force multiplied by the moment arm from that bolt to the nearest yield line.

The force in the bolts is determined using simple statics. The column axial tension force is equally divided among the anchor bolts then added to the force in each bolt due to overturning moment. Free body force distribution is used to determine the load in each bolt due to overturning. See [Design Methodology](#) for a discussion of this procedure and its possible limitations.

The capacity and unity check are then calculated for each bolt and the governing value is reported as the controlling value.

Anchor Bolt Tension-

This limit state checks the available tension strength of the bolts in tension per *AISC 360-10 section J3.7*. It is checked independently for weak axis and strong axis bending.

Anchor Bolt Shear-

This limit state checks the available shear strength of the bolts per *AISC 360-10 section J3.6*.

Anchor Bolt Bending-

This limit state checks the available tensile stress (calculated per *AISC 360-10 section J3.7*) against the total required tensile stress which includes both bending stress and the axial tensile stress from the Anchor Bolt Tension limit state (when applicable).

Note:

- This is only applicable if there is both shear in the anchor bolts and Plate Washers are applied.

Anchor Bolt Bearing on Base Plate-

This limit state checks the bearing of the anchor bolt (due to the resultant of the shear loads) on the base plate per *AISC 360-10 section J3.10*. It is only applicable when there is shear in the anchor bolts and there are no plate washers applied.

Per the suggestions of the AISC Design Guide 1, only two anchor bolts are considered to resist the shear.

Anchor Bolt Bearing on Plate Washer-

This limit state checks the bearing of the anchor bolt (due to the resultant of the shear loads) on the plate washer per *AISC 360-10 section J3.10*. It is only applicable when there is shear in the anchor bolts and plate washers are applied.

Plate Washer Bending-

This limit state checks the plate washer in bending. The design code gives no direct procedure for this limit state, so RISACONNECTION bases it on simple physics. The bending in the plate is similar to that in a cantilever beam. The outside edge is assumed to be fully fixed where the edge is welded to the base plate. The inside edge of the hole is assumed free where the tension load is applied (at the anchor bolt).

Assuming that the washer is divided into 'n' pie slice segments, the design values are calculated as:

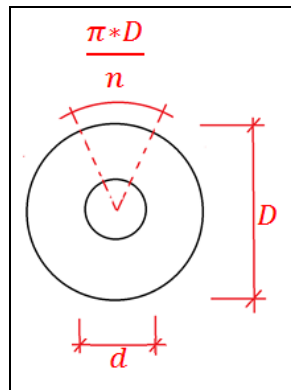

$$M_u := T_u \cdot \left(\frac{d_h}{2} - \frac{d_{p_hole}}{2} \right)$$

Bending at Plate Washer

$$M_n := F_y \cdot \pi \cdot d_h \cdot \frac{t_{pw}^2}{4}$$

Plate Washer Bending Capacity

Where:

- T_u = maximum anchor bolt tension
- d_h = anchor bolt hole diameter (in base plate)
- d_{p_hole} = anchor bolt hole diameter (in plate washer)
- t_{pw} = thickness of plate washer

Plate Washer Punching Shear-

This limit state checks the tensile strength of the plate washer against punching shear from anchor bolts in tension. It is only applicable when at least one anchor bolt is in tension and plate washers have been applied.

Column Weld Limitations-

This checks geometric limitations of the weld at the column to the base plate. See [Weld Limitations](#) for more information.

Web Weld Limitations-

This checks geometric limitations of the weld at the column web (for Wide Flange columns only) to the base plate. See [Weld Limitations](#) for more information.

Flange Weld Limitations-

This checks geometric limitations of the weld at the column flange (for Wide Flange columns only) to the base plate. See [Weld Limitations](#) for more information.

Plate Washer Weld Limitations-

This checks geometric limitations of the weld at the plate washers to the base plate. See [Weld Limitations](#) for more information.

Column Web Weld Strength-

This checks the weld strength at the column web to the base plate. See [weld strength](#) for more information.

Column Flange Weld Strength-

This checks the weld strength at the column flange to the base plate. See [weld strength](#) for more information.

Plate Washer Weld Strength-

This checks the weld strength at the plate washer to the base plate. See [weld strength](#) for more information.

Anchorage Design Checks

The anchorage design report includes the following checks. All references to ACI are based on ACI 318-19, unless stated otherwise. Please note that the anchorage design functionality is exclusively available when the Steel Code is set to LRFD. While RISACONNECTION allows for the input of moments about both the strong and weak axes independently, please be advised that according to AISC Design Guide 1 (2nd Ed.), the software does not currently integrate these inputs into a combined two-way bending analysis. Results are evaluated separately for each axis, and the results in the detail report states "Simultaneous strong and weak axis effects are not considered" for applicable limit states.

Steel Tension (Strong Axis) / (Weak Axis)-

RISACONNECTION performs tension checks on steel anchors according to ACI 318 Eq. 17.6.1, using the required loads from the 'Load Distribution' checks found on the Base Plate tab. Consistently, the software assumes 'Ductile' steel behavior as per ACI 318-19, Table 17.5.3(a), and applies the corresponding strength reduction factor for both tension and shear strength design checks.

Concrete Breakout (Tension) (Strong Axis) / (Weak Axis)-

RISACONNECTION evaluates concrete breakout in tension according to ACI 318-19 Section 17.6.2, assessing both individual anchors and anchor groups. This analysis incorporates the forces determined from 'Load Distribution' checks, calculating breakout strength based on each anchor's effective embedment depth and its proximity to the concrete edge.

Anchor group effect for Concrete Breakout in Tension (Strong Axis) / (Weak Axis)-

For groups of anchors, RISACONNECTION determines the combined breakout strength based on spacing and group geometry, employing the ACI 318-19 guidelines to calculate the reduced capacity due to spacing and edge effects.

Concrete Pullout (Strong Axis) / (Weak Axis)-

Determines the pullout capacity of cast-in-place anchors per ACI 318 Eq. 17.6.3.1, considering the concrete's compressive strength and anchor's bearing area.

Concrete Side-Face Blowout (Strong Axis) / (Weak Axis)-

RISACONNECTION conducts Concrete Side-Face Blowout checks according to ACI 318-19 Sect. 17.6.4. The check focuses on corner bolts in multi-bolt layouts due to their proximity to concrete edges. For symmetrical connections, distances ca_1 and ca_2 are identical for all corner bolts and clearly defined. In asymmetrical setups, the bolt with the smallest ca_1 and ca_2 is selected for evaluating blowout strength, using the maximum tension from any bolt as the required load. This ensures accuracy for symmetrical configurations and conservative assessments for asymmetrical ones.

Steel Shear-

RISACONNECTION analyzes the shear capacity of steel anchors in accordance with ACI 318 Section 17.7.1. Additionally, it adheres to AISC Design Guide 1, Section 3.5.3 for shear force distribution among anchor rods. When welded plate washers are not used, typically only two anchor rods are employed to transfer shear forces, simplifying design calculations and ensuring compliance with established guidelines. Conversely, when welded plate washers are used, shear forces are evenly distributed across all anchors, thereby enhancing the connection's stability and strength by utilizing the full capacity of the anchoring system.

Note:

- When a **Grout Pad** is present (**Grout Pad = Yes**), the nominal steel shear strength V_{sa} is multiplied by a reduction factor of **0.80** per ACI 318-19 Section 17.7.1.2.1. This accounts for the increased lever arm and bending effects introduced by the grout thickness per AISC Design Guide 1, 3rd Edition, Section 4.3.4.3.

Concrete Breakout in Shear (Strong Axis) / (Weak Axis)-

RISACONNECTION examines the potential for concrete breakout in shear according to ACI 318 Section 17.7.2, focusing on the proximity of anchors to edges and the applied loads. It conducts Concrete Edge Breakout checks in alignment with ACI 318-19, specifically section R17.7.2.1 of the commentary. Each shear demand component, whether strong or weak axis shear, is assessed separately to precisely evaluate the concrete's structural integrity. For example, a 10 kip strong-axis shear and a 10 kip weak-axis shear are independently verified. This method ensures compliance with ACI standards, and a clarifying note at the bottom of the "Concrete Breakout in Shear" checks further references ACI 318-19 section R17.7.2.1 for detailed guidance.

Anchor group effect for Concrete Breakout in Shear (Strong Axis) / (Weak Axis)-

When assessing shear breakout, RISACONNECTION takes into account the layout and number of anchors in a group. This approach adjusts the shear capacity calculation considering the interaction between closely spaced anchors.

Concrete Pryout in Shear-

Checks the resistance of anchors against concrete pryout forces in shear per ACI 318 Section 17.7.3.

Anchor group effect for Concrete Pryout in Shear-

RISACONNECTION incorporates the effects of anchor group configurations on the pryout strength in shear. The software assesses the increased risk and potential reduction in strength due to the collective influence of multiple anchors.

Tension and Shear Interaction (Strong Axis) / (Weak Axis)-

Evaluates the interaction effects between tensile and shear forces acting on anchors per ACI 318 Section 17.8, ensuring that combined stresses remain within acceptable limits.

Concrete Splitting-

Considers the potential for concrete splitting due to tensile forces on anchors per ACI 318 Section 17.9, especially in cases with close edge distances or high load demands.

Supplemental Reinforcement (Anchor Reinforcement)-

When Anchor Reinforcement – Shear and/or Anchor Reinforcement – Tension are enabled, the applicable concrete breakout limit states are treated as not applicable and are reported as n/a in the anchorage design report. For these checks, the detail report includes a note stating that anchors and reinforcement have been specifically detailed by the engineer to transfer anchor shear and/or tension into the foundation in accordance with ACI 318-19 Section 17.5.2.1, and therefore the corresponding concrete breakout limit state is not considered. RISACONNECTION does not verify the adequacy or detailing of this reinforcement.

Perform Anchorage Calc-

Anchorage Design can be toggled on/off in the base plate feature of RISACONNECTION. This option is beneficial when engineers need to focus solely on base plate design and exclude anchorage design from the code check, preventing unity check failures due to anchorage considerations. This feature is especially useful for those who prefer performing anchorage design separately in HILTI PROFIS.

Connection Properties	
Connection	
Connection Title	Connection 2
Connection Type	Single Column Base Plate Connection
Anchorage	
Anchorage Type	Cast-in-place
Perform Anchorage Calc	Yes
Connection Category	
Bolt Layout	Four
Flange Weld	Yes
Plate Washers	No

The toggle will be enabled by default, but users can disable it when anchorage design is unnecessary. When the "Perform Anchorage Calc" option is enabled, full anchorage calculations will be performed, including the display of results in the Project Explorer. When disabled, only base plate calculations will be performed, and a message will indicate that anchorage design is turned off. When anchorage calculations are enabled, the Anchor Reinforcement – Shear and Anchor Reinforcement – Tension inputs may be used to indicate that supplemental reinforcement will be detailed outside the program, which bypasses the corresponding concrete breakout checks.

Additional Brace to Base Plate Design Checks

In addition to the checks described above, the following checks are also included when you use the Brace to Column Base Plate connection type:

Loading at Gusset to Column-

This check is available on the **Gusset/Column** tab of the Results report to show the full details of the loads calculation at this sub-connection interface. This is done per the design methodology of section 4.3 of the *AISC Design Guide 29: Vertical Bracing Connections - Analysis and Design*.

Loading at Base Plate-

This check is available on the **Base Plate** tab of the Results report to show the full details of the loads calculation at this sub-connection interface. This is done per the design methodology of section 4.3 of the *AISC Design Guide 29: Vertical Bracing Connections - Analysis and Design*.

Column Web Bending-

This check is available on the **Gusset/Column** tab of the Results report. Per *AISC Design Guide 29: Vertical Bracing - Analysis and Design* section 4.3, the web of a Wide Flange column (or the wall of a HSS Tube column) must be designed for the out of plane bending. Equation (4-17) in the *Design Guide* calculates the amount of out of plane load that the web can carry per yield line analysis. RISACONNECTION compares this allowable value to the applied moment due to eccentricity on the column web.

Note:

- Wide Flange columns use an effective length factor of $k = 4 + 2\sqrt{2} + 6(L/h) + (h/L)$. See page 39 of the *Design Guide* for more information on the other variables.
- For HSS Tube column walls, RISACONNECTION assumes that the wall is fixed to the flanges, and therefore takes $k = (h/L) + 8(L/h) + 8$. See page 39 of the *Design Guide* for more information on the other variables.

RISAFloor and RISA-3D Integration

RISACONNECTION has the ability to integrate with RISAFloor and RISA-3D. The integration involves importing all geometry, member sizes, design specifications, and loading into RISACONNECTION seamlessly from RISAFloor and/or RISA-3D. To learn how to take the model into RISACONNECTION, view the **RISACONNECTION Integration** topic within the RISAFloor or RISA-3D help file. This portion of the help file will explain how everything works on the RISACONNECTION side.

When first coming into RISACONNECTION from RISAFloor or RISA-3D you will see that the file is populated with all of the VALID connections. Thus, only connections that RISACONNECTION can actually design will be brought over. Exporting to RISACONNECTION from RISAFloor or RISA-3D will create a RISACONNECTION file (with a .rcn extension) that will have the same name as the RISAFloor or RISA-3D model and will be located in the same directory.

Notes:

- See the RISACONNECTION Integration topic within the RISAFloor and RISA-3D help file for more information on connection limitations.
- It is necessary for RISACONNECTION and RISA3D/RISAFloor to be running at the same User Account Control privilege level in order for the two programs to properly communicate with each other. If RISACONNECTION is started via RISA3D/RISAFloor it will be running at the same privilege level. However, if opening both programs manually make sure the privileges are the same to guarantee proper behavior.
- For details on the requirements to export a seismic connection from RISA-3D, see the [Seismic Connection Detailing](#) topic.

Connection Grouping

Once you have imported your information in RISACONNECTION, you will see that the connections are grouped in the **Project Explorer**.

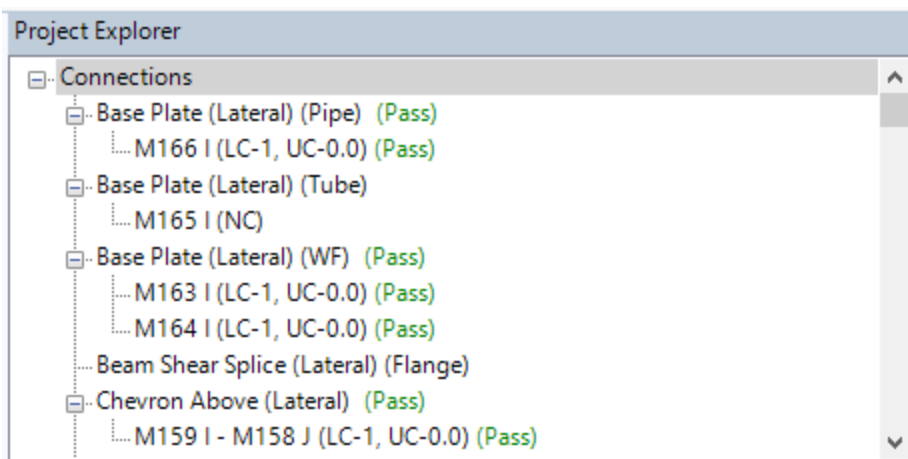

The groups in RISACONNECTION are based on the Connection Rules from RISAFloor and RISA-3D. Within each Connection Rule, however, there are also groupings based on whether the members are lateral vs gravity and whether a column/beam connection frames into the web or flange of the column. Therefore, a single connection rule could potentially create as many as four groupings in RISACONNECTION.

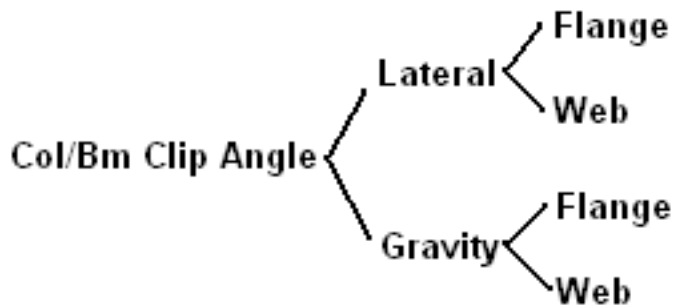

A **Lateral** member is a member that has been defined in RISAFloor as Lateral, or is a 3D-only member.

A **Gravity** member is a member defined in RISAFloor as Gravity.

The grouping is also dependent on the Shape Type used in the connection. Here is a breakdown:

Shear Tab, Clip Angle and End Plate Connections

- Each column shape type (Tube, Pipe, WF) will get its own group.
- Wide flange columns will be split into Flange and Web groups.
- Tube columns will all be grouped together.
- Pipe columns will all be grouped together

Note:

- The “Bolted to Column” sub-option for clip angles and end plates is invalid for tube and pipe columns and a warning will be generated.
- Clip angle and end plate connections are invalid on pipe shapes and a warning will be generated.

Vertical Brace and Chevron Connections

- All vertical brace connections which have similar brace shape types (L, LL, WT, HSS, Pipe, WF, Channels) set as top-only, bottom-only, or both will be in their own group.
- All chevron brace connections which have similar brace shape types (L, LL, WT, HSS, Pipe, WF, Channels) will be in their own group.
- All brace connections where the top and bottom brace are different shape types are invalid for integration and will give a warning message.

Grouping Behavior

In the Project Explorer there are three levels: Project level, Group level, and Connection level. These levels are nested within each other and allow you to change design and connection properties quickly and easily. There are also properties that can only be changed within RISAFloor or RISA-3D. Here we will discuss these different connection property categories and how to use them properly.

RISAFloor and RISA-3D Level

Items that can only be modified from RISAFloor or RISA-3D

- Design Method (ASD or LRFD).
- Grouping of Connections: If you wish to move a connection to a different connection group then you must go into RISAFloor or RISA-3D and modify that member end’s Connection Rule.

- Properties that are defined within the Connection Rules of RISAFloor or RISA-3D. These currently consist of whether the connections are welded or bolted to each other. If you wish change from bolted to welded or vice versa you must also do this within RISAFloor or RISA-3D.
- Properties that are defined within the Seismic Design Rules of RISA-3D (if it is a [seismic](#) connection type).

If you wish to modify any of these properties you need to go back to the RISAFloor or RISA-3D model, make the change, and then re-export to RISAConnection.

Project Level

When you click the project label in the **Project Explorer**, the **Project Properties** are then shown.

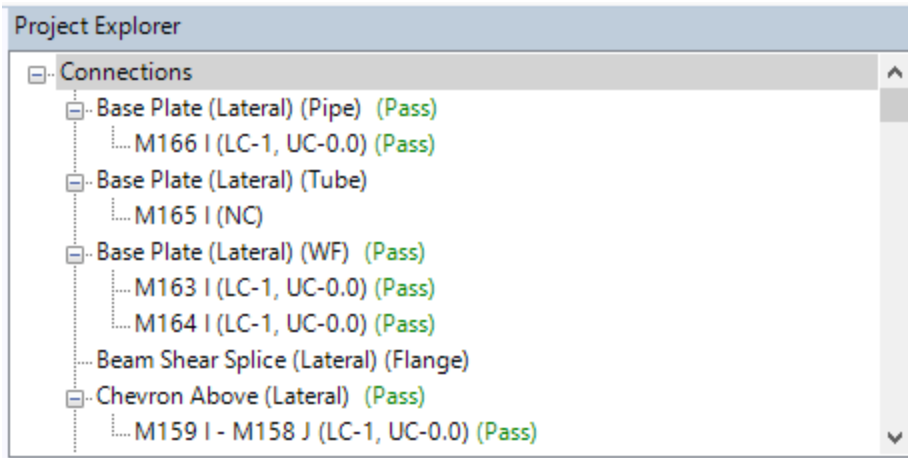

Load Combination:

Project Properties	
Project Description	
Project Title	Connections
Company	
Designer	
Job Number	
Notes	< Notes... >
Project File	
File Path	C:\Users\caitlinm\Desktop\Managing RISACorr
Project Solution	
Design Method	AISC 14th (360-10): LRFD
Bolt Group Analysis Method	Center of Rotation
Weld Analysis Method	Center of Rotation
Consider Bolt Hole Deformation	True
Check Rotational Ductility	True
Check Weld Filler Metal Matchin	True
Full Shear Ecc. Considered	False
Panel Zone Deform. Considered	False
Project Title	
Title of current project	

Here you can update information in the **Project Description** fields and some of the options from the **Global Settings - Solution** tab.

Note:

- When you click the Project in the **Project Explorer** the left screen shows all of the groups in the project and gives a representative view of each.

Group Level

When you click on a Group in the **Project Explorer** then the **Group Properties** are shown.

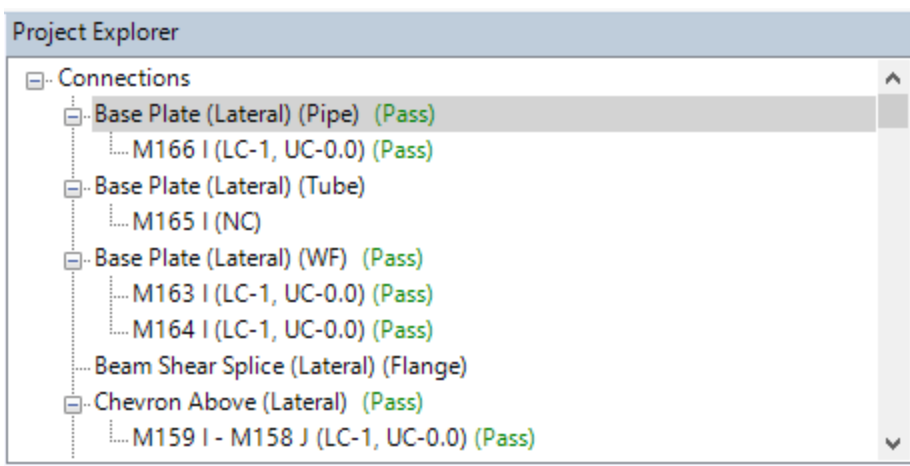

In the Group Properties you can modify connection properties for all of the connections within this group at one time. The grayed out properties are properties brought over directly from RISAFloor and RISA-3D; these properties can not be edited in RISAConnection.

If an item is labeled **-Various-** it means that there are multiple values in this field for the different connections in this group.

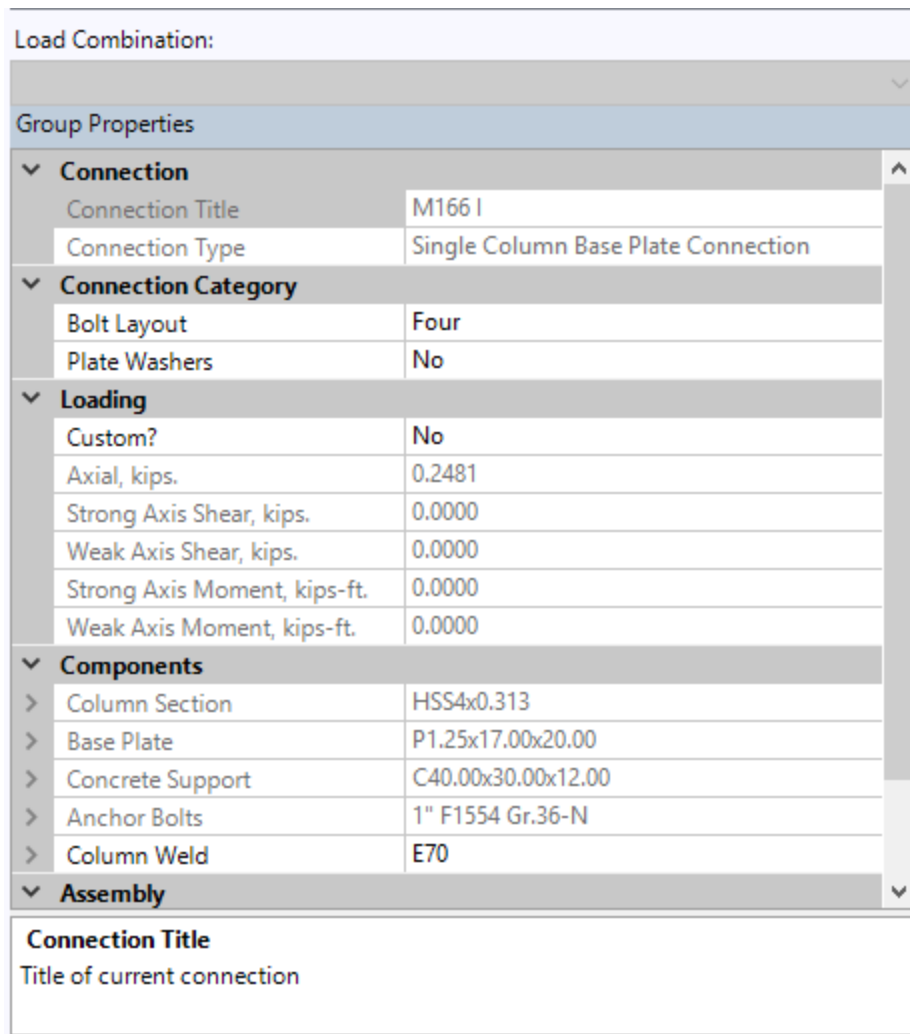

Note:

- If you have changed individual connection properties and then go back to the group, changes here will overwrite any of those individual connection changes.
- When you click a Group in the **Project Explorer** the left screen shows all of the connections graphically in that group.

Connection Level

When you click on an individual connection, that connection's properties are shown.

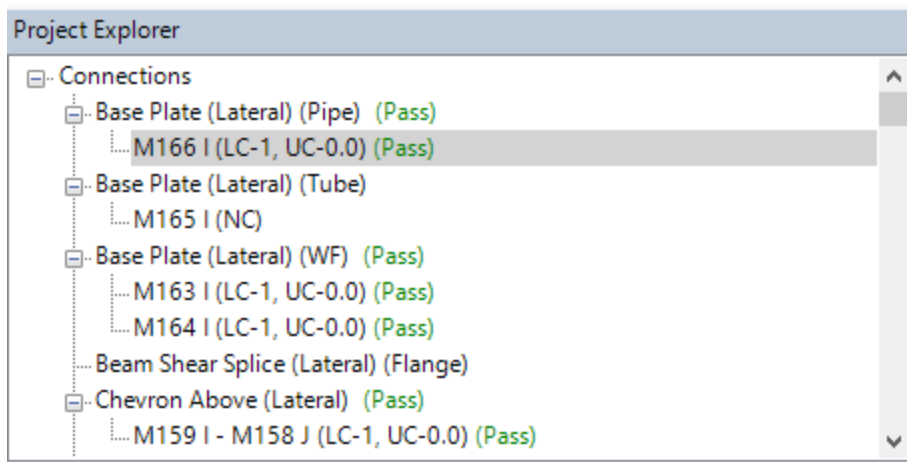

The grayed out properties within an individual connection may be either RISAFloor/3D controlled, Project level controlled, or Group level controlled. You must go up to those levels to change these properties for these connections.

Load Combination:
1. 3D - 1 - IBC 16-1

Connection Properties

Connection	
Connection Title	M166 I
Connection Type	Single Column Base Plate Connection
Connection Category	
Bolt Layout	Four
Plate Washers	No
Loading	
Custom?	No
Axial, kips.	0.2481
Strong Axis Shear, kips.	0.0000
Weak Axis Shear, kips.	0.0000
Strong Axis Moment, kips-ft.	0.0000
Weak Axis Moment, kips-ft.	0.0000
Components	
Column Section	HSS4x0.313
Base Plate	P1.25x17.00x20.00
Concrete Support	C40.00x30.00x12.00
Anchor Bolts	1" F1554 Gr.36-N
Column Weld	E70
Assembly	

Connection Title
Title of current connection

Loading/Load Combinations

All load combinations from RISAFloor and RISA-3D that have the Connection check-box selected in the Load Combinations spreadsheet will be brought into RISACONNECTION. There is a **Load Combination** drop-down in the upper-right hand corner. This drop down is only available when looking at an individual connection. You can scroll through the load combinations and viewing the loading and results for each. The load combinations are renumbered because it is possible to bring load combinations from both RISAFloor and RISA-3D into RISACONNECTION. Since we are potentially combining two sets of load combinations, RISACONNECTION must renumber them for clarity. The program is listed in front of the load combination in the RISACONNECTION menu as show below ("3D" means that the combinations came from your RISA-3D model).

Load Combination:

1. 3D - 1 - IBC 16-1	▼
1. 3D - 1 - IBC 16-1	
2. 3D - 2 - IBC 16-2 (a)	
3. 3D - 3 - IBC 16-5	
4. 3D - 4 - IBC 16-7	
5. 3D - 5 - IBC 16-5	
6. 3D - 6 - IBC 16-7	

When you are viewing a specific load combination then you can see the forces for the connection in the Loading section. For moment connections you can also see the **Top Column Dist**, **Column Force** and **Story Shear** values that are brought over from the RISAFloor or RISA-3D model as well. By default, these forces are only available for viewing.

Loading	
Custom?	No
Shear Load, kips.	0.8031
Beam Axial Load, kips.	-0.0218
Top Column Dist, in.	0.0000
Column Force, kips.	1.8406
Story Shear, kips.	-0.0061
Top Brace Axial, kips.	0.1666
Bottom Brace Axial, kips.	-0.1025

But if you set the **Custom Loading** flag to "Yes" then you can edit the loads to whatever you want. Just note that this no longer corresponds to the RISA-3D/RISAFloor loading.

Loading	
Custom?	Yes
Shear Load, kips.	0.8031
Beam Axial Load, kips.	-0.0218
Top Column Dist, in.	0.0000
Column Force, kips.	1.8406
Story Shear, kips.	-0.0061
Top Brace Axial, kips.	0.1666
Bottom Brace Axial, kips.	-0.1025

Note:

- When you click an individual connection, the **Load Combination** menu jumps to the LC which produces the worst case code check.
- The **Column Force** and **Story Shear** values are only considered for RISA-3D load combinations.

Solving Connections

Once you get the connections configured properly you need to solve the model. You can solve the model by connection, by group or for the entire project. Every load combination from RISAFloor and RISA-3D will be solved each time.

There are two ways to access solving options:

1. From the **Home** tab on the ribbon toolbar:

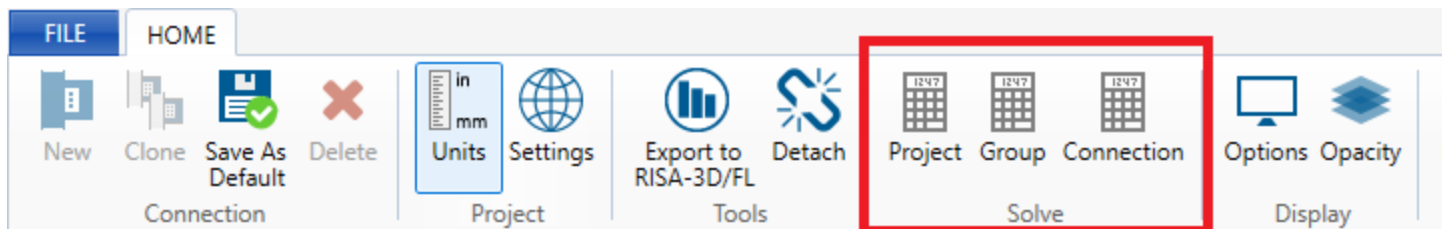

2. From the right-click menu in the **Project Explorer** (right-clicking the Project line will solve the entire project, the Group line solves the group, and an individual connection solves that connection only).

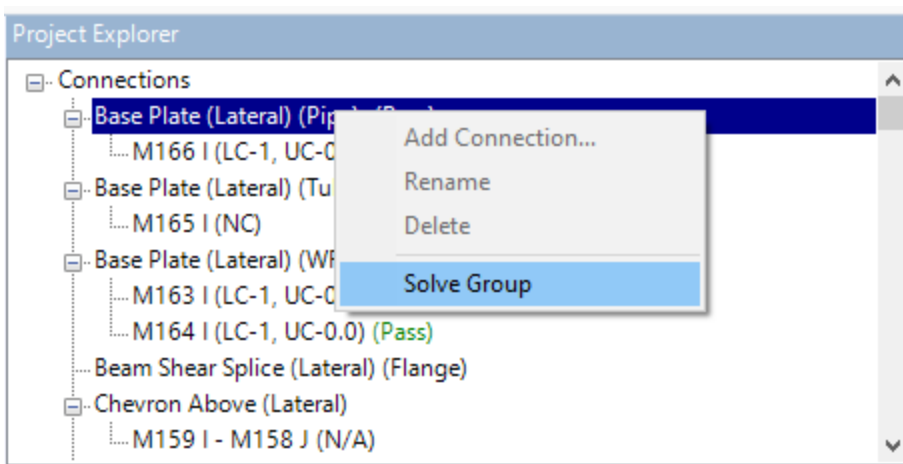
**Note:**

- If you are using RISAConnection as a standalone program then these solve buttons have no use because the model is re-solved automatically each time a change is made.

Viewing Results (in RISAConnection)

Once you have a connection, a group, or the entire project solved you will be able to view results via the **Project Explorer** or **Reports** tab.

Project Explorer

The **Project Explorer** gives a summary of the design results for the project. Each connection gives a Pass or Fail notification, along with the Max UC and the LC that produced it.

The Group will state "Pass" if all of the connections within the group passes. It will state "Fail" otherwise.

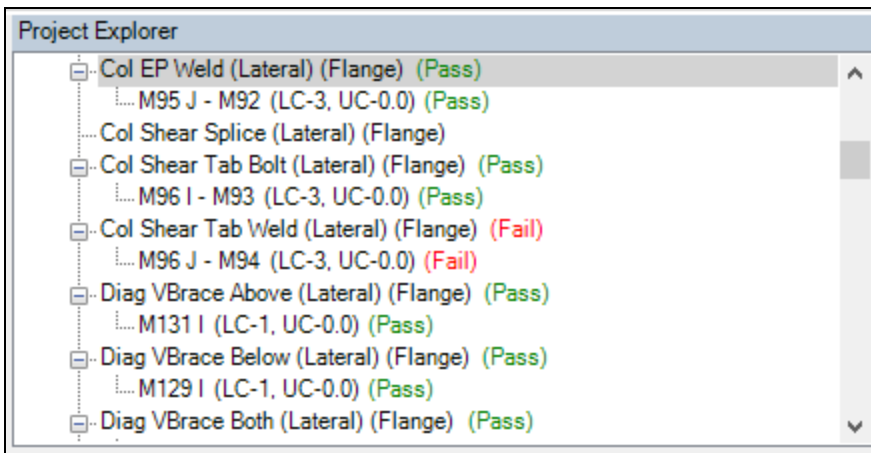

If a property is changed then the connections whose properties are affected will be invalidated. If you modify a single connection then the results for that connection will be invalidated and an (N/A) will be shown.

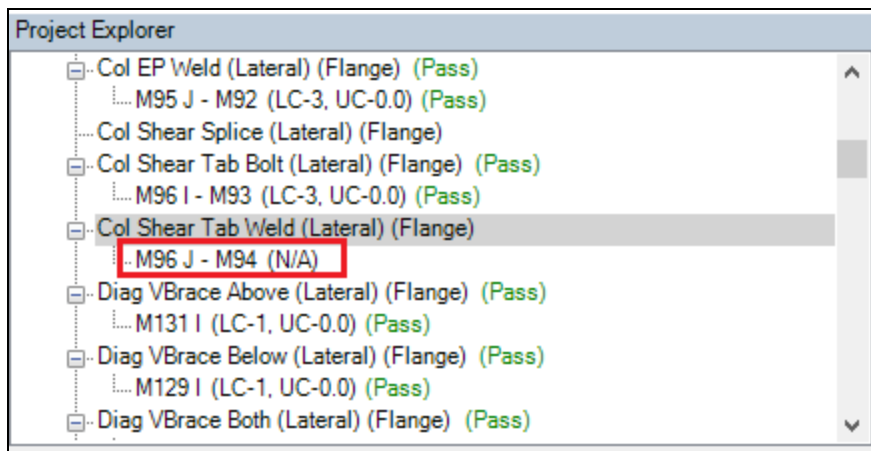

In this scenario you can simply re-solve that connection to get results again.

If you invalidate a group property then that will invalidate all of the connections within that group. If you invalidate a project property, then it will invalidate all connections in the project.

Reports

The **Report** view gives the unity checks for the load combination shown in the **Load Combination** dropdown. The load combination selected by default is the one that produced the worst case unity check value. The **Reports** section will show which Limit State produced this value.

Limit State	Required	Available	Unity Check	Result
Geometry Restrictions at Left Beam Web				PASS
Geometry Restrictions at Right Beam Web				PASS
Geometry Restrictions at Left Beam Flange				FAIL
Geometry Restrictions at Right Beam Flange				FAIL
Plate Shear Yield	0.00 kN	166.98 kN	0.00	PASS
Left Beam Shear Yield	0.00 kN	658.12 kN	0.00	PASS

If the connection you are viewing has its results invalidated by changing a connection property, then this message will be shown:

Report not calculated. Press here for Calculation!

If this message is shown then the results shown are invalid. Pressing this message has the effect of solving that individual connection for all load combinations. The program will then give valid results for this connection.

Viewing Results (in RISAFloor or RISA-3D)

Once you have your connections configured properly you can take those results back to RISAFloor and RISA-3D to be viewed in the **Connection Results** browser and graphically. To do this you must have the RISAFloor or RISA-3D model opened and solved.

- Choose **File-Export Connection Results**.

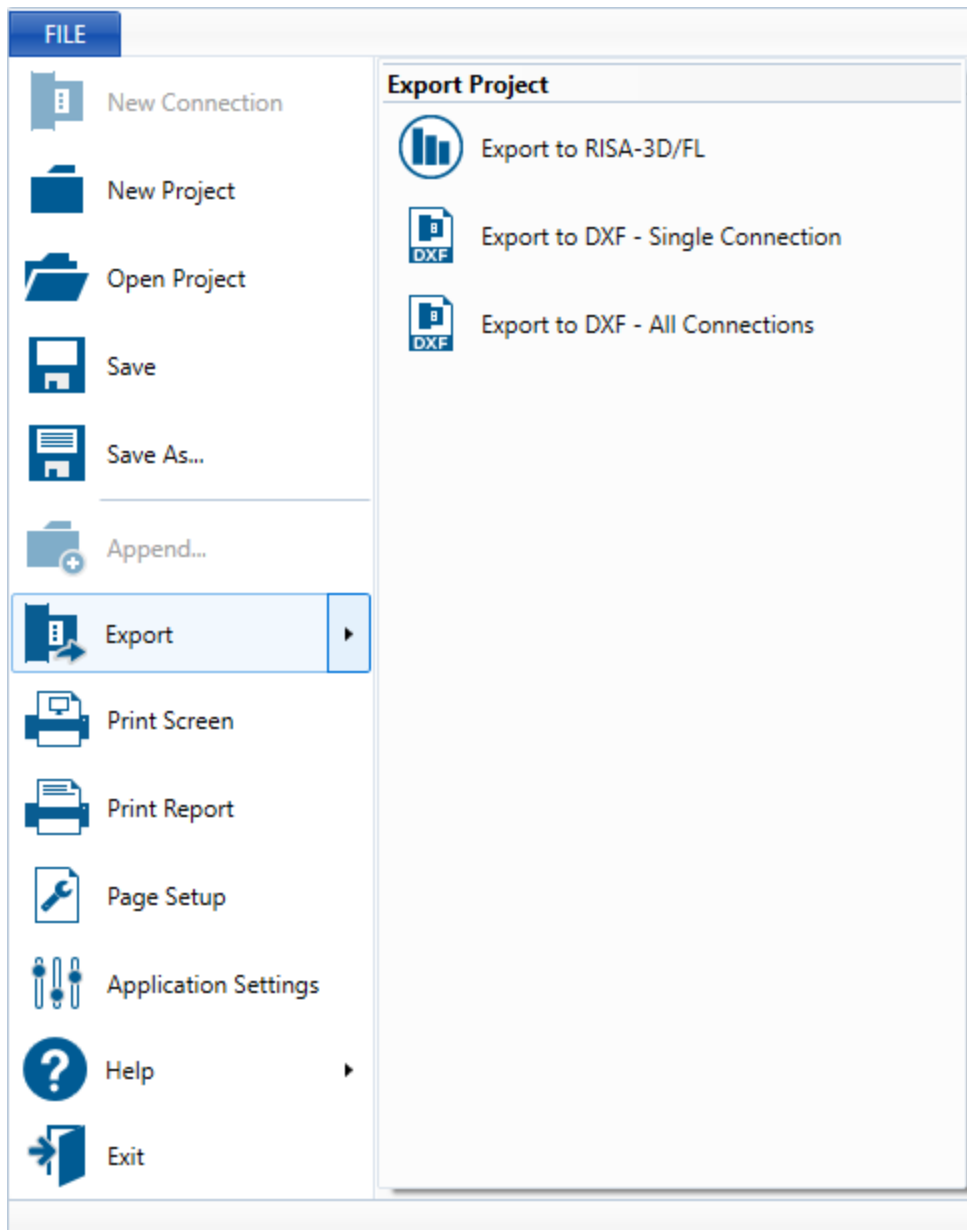

- Alternatively, you can simply click the **Export to RISA-3D** button from the ribbon toolbar.

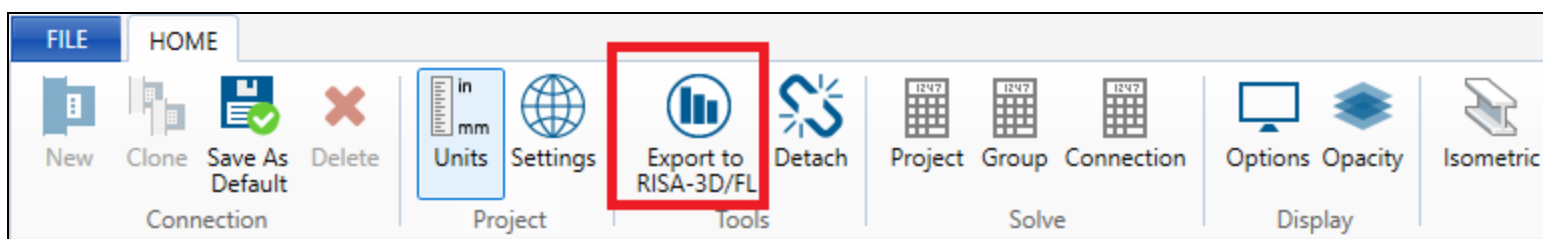

Round-tripping between RISAFloor/RISA-3D and RISAConnection

The RISAFloor/RISA-3D and RISAConnection integration is meant to be used for multiple round-trips. Items to note with this integration:

- Any items that are controlled by RISAFloor or RISA-3D will be overwritten in the RISAConnection file EVERY time the RISAFloor or RISA-3D model sends results to RISAConnection. This includes loading, section sizes, connection types, etc.
- Items that are controlled by RISAConnection will NOT be overwritten by RISA-3D or RISAFloor. If you have modified a connection in RISAConnection, these changes will be saved. An *exception* occurs if you modify the Connection Rule for a particular member end. In this scenario, the new connections defaults will overwrite your changes.
- To go back and forth between the different programs you must make sure that the files are in the same directory and have the same file name (with different file extensions). You can move files around to work on them separately, but they must be located together to take advantage of the integration. If you move or rename the RISAConnection file, then the next time RISAFloor or RISA-3D tries to interact with RISAConnection it will simply create a new file.
- Member sections used when round-tripping MUST be saved to the shapes databases. Section that are only saved to the RISAFloor or RISA-3D file can not be read into RISAConnection. Sections that are saved in the AISC_BACKUP can not be read either. Connections that have sections saved only to the file or only to the AISC_BACKUP directory will not be designed.
- An temporary "exchange" file is created each time the connection information is updated. This file is named 3DRFRC.TMP and should be located in the directory where the RISA-3D INI file is located. If there is a problem creating or editing this file, then this will cause significant problems with interaction between the programs.

Detach

When a RISAConnection model is created by exporting from RISA-3D, RISAFloor, or Revit, many of the input options are grayed out. These are the parameters that are defined in the original program (RISA-3D, RISAFloor, or Revit). To release the integrated ownership of the RISAConnection model, you can *detach* the RISAConnection file. This releases the ownership so you have control to change all input parameters in RISAConnection.

If you want to detach the RISAConnection file, simply click on the **Detach** button once in RISAConnection. The program will give you a warning and then, if you click **Yes**, detach and rename the file.

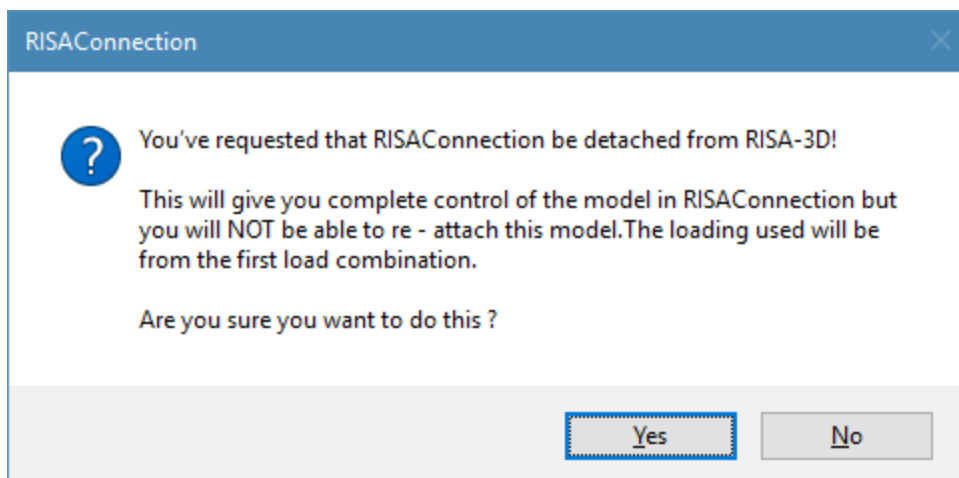
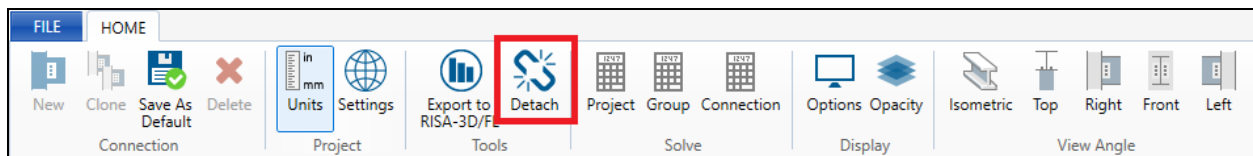

Note:

- Once detached, only the loading from the first load combination is available. However you now can manually enter any loading that you want.
- There is no way to re-attach the RISAConnection model, so we suggest saving a back up copy before detaching.
- Connection grouping is also lost when you detach. The connections will be re-ordered alphabetically.

Miscellaneous

Live Load Reduction in RISAFloor

When connections are transferred from RISAFloor to RISAConnection, live load reduction is accounted for in the reactions that are transferred.

Hilti PROFIS Integration

Base plates can be exported from RISACONNECTION to Hilti PROFIS Engineering for design of the anchor bolts and check concrete pull-out.

The Tools section of the Home tab includes the **Export to PROFIS** and **Import PROFIS Results** buttons.

The **Export to PROFIS** button will allow you to export the geometry and loads for a Single Column Base Plate connection to Hilti PROFIS

The **Import PROFIS Results** button will allow you to import the Hilti PROFIS report to be incorporated into the RISACONNECTION printed report.

Exporting to Hilti PROFIS

After you have solved the connection in RISACONNECTION that you would like to send to Hilti PROFIS for anchor bolt design, press the **Export to PROFIS** button.

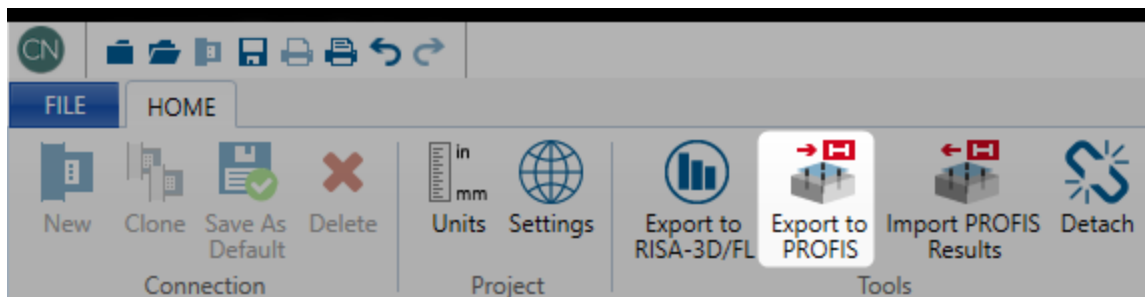

First Time Export

If this is your first time exporting a model to Hilti PROFIS, RISACONNECTION will prompt you with a window to login to your Hilti PROFIS account.

Note: Connection to internet is required to export to Hilti PROFIS.

Enter your login information and press the log in button.

Contact Hilti for further information on obtaining an account.

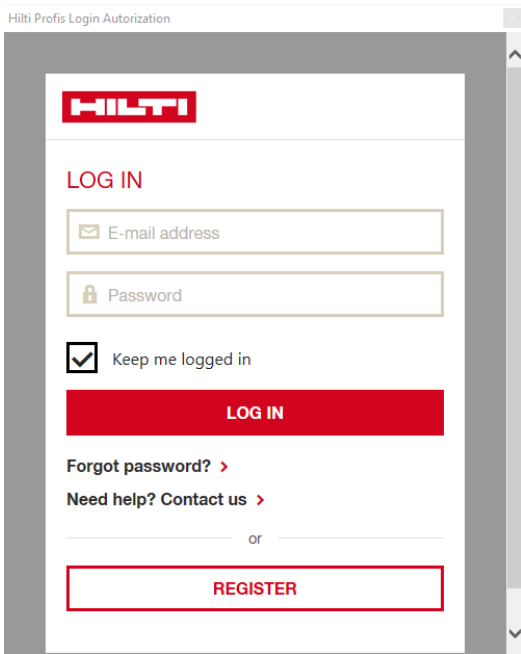

After the first time, the login information is stored.

Once the Log In screen closes, press the **Export to PROFIS** button once more.

If you have multiple column base plate connections, the message shown below will appear where you can choose multiple connections to export.

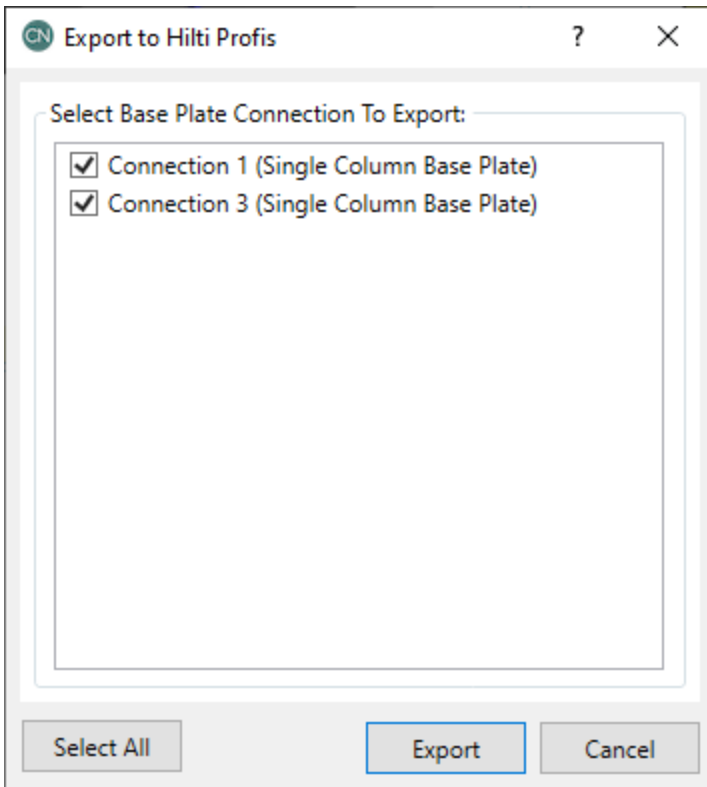

Once you press **Export**, the message shown below should appear which indicates that the connection is now available on your Hilti PROFIS account.

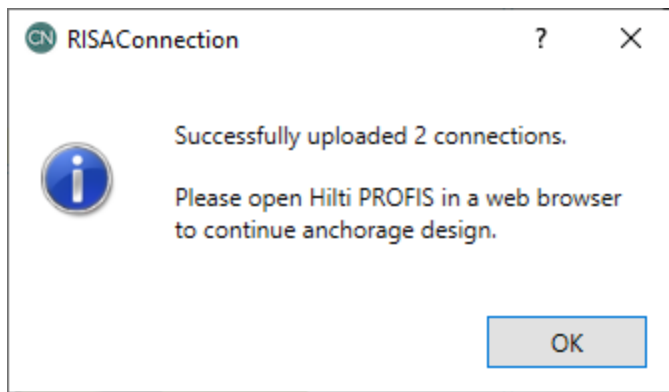

You can open a web browser and login to your Hilti PROFIS account at <https://profisengineering.hilti.com>

Upon logging in, you should be prompted with the message below informing you that a new transfer has occurred from RISACONNECTION.

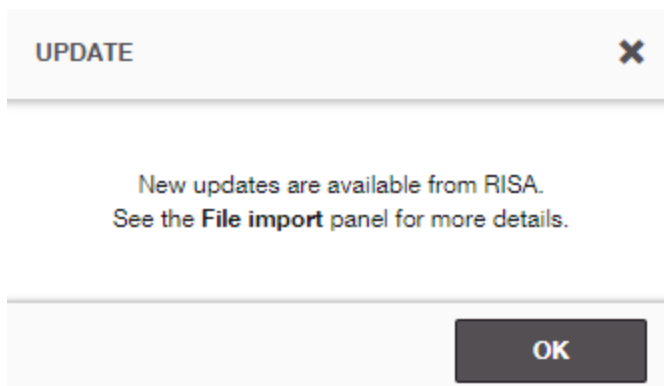

Press OK and on the right-hand side of the Hilti PROFIS interface there is a section called File Import. Press the **Click to update from RISA** button.

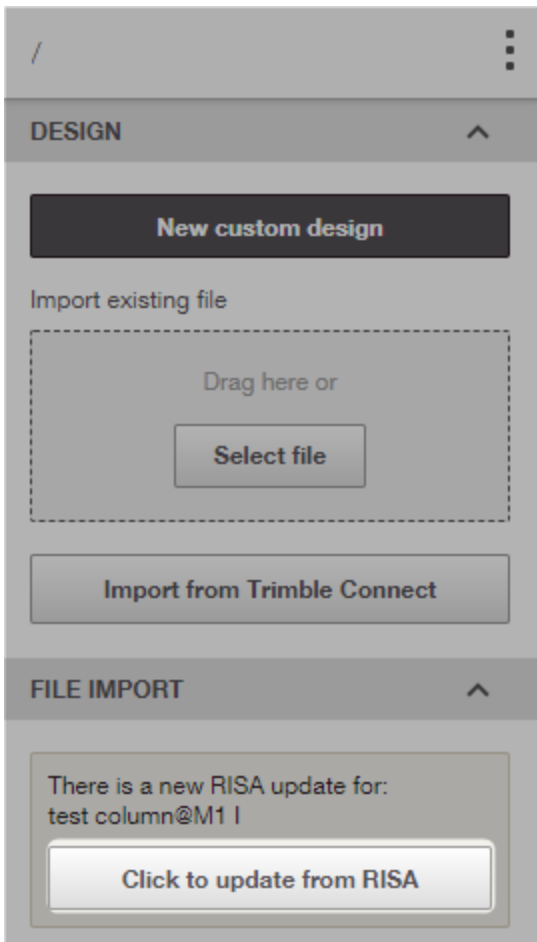

You will be taken to a page where you can see the connection sent from RISAConnection. Here, you can make anchor bolt changes as required to achieve the desired results.

Importing Hilti PROFIS Results

Once the anchors are designed in Hilti PROFIS, the report can be imported to a designated file path. To do this, press the **Loads / calculation type** button in Hilti PROFIS and then press the **Export RISA** button.

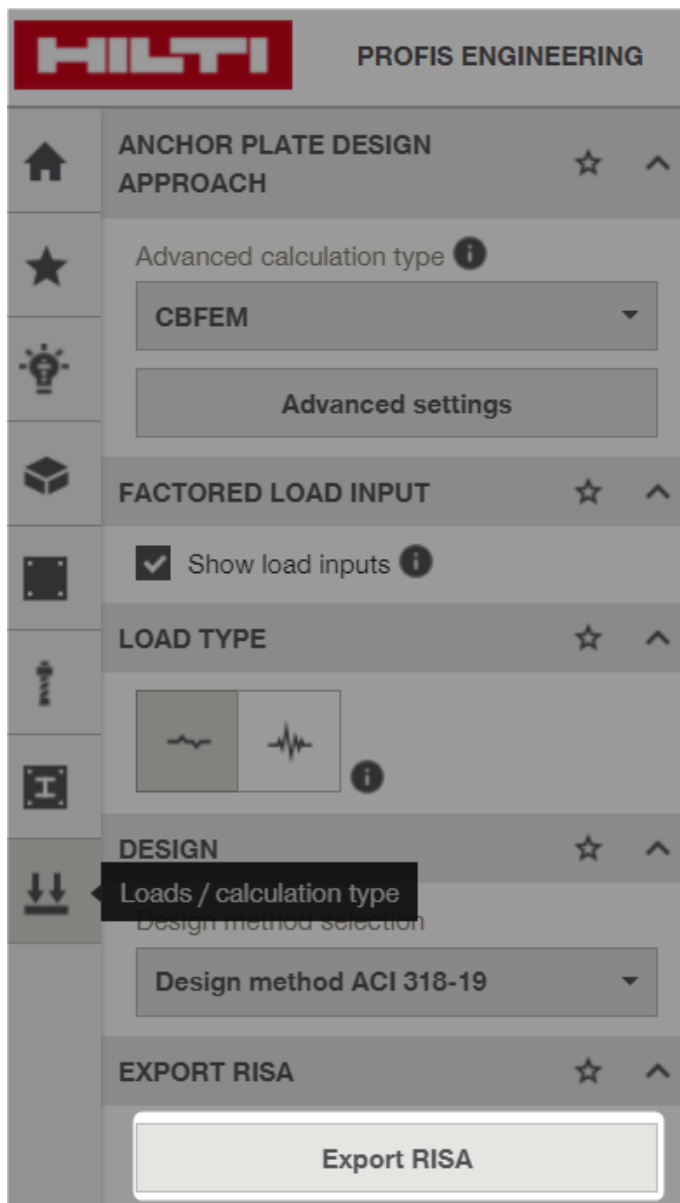

Then press the **Export to RISA** button in the **Generate Report** window that appears.

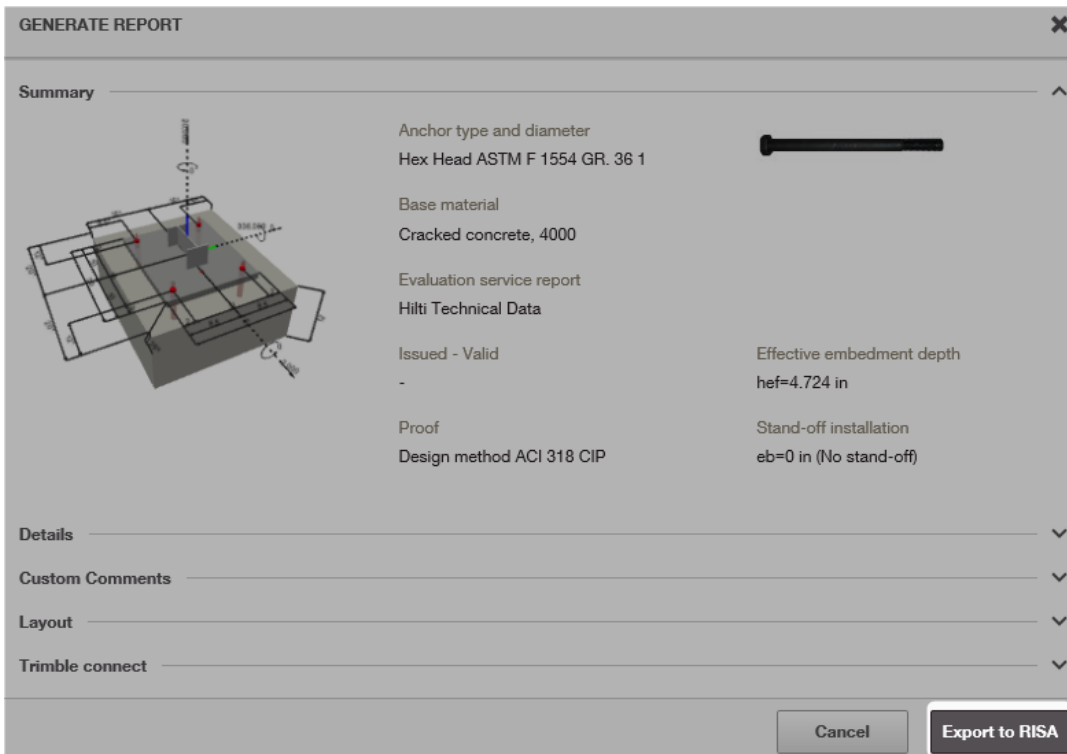

Then go back into RISACONNECTION and press the **Import PROFIS Results** button.

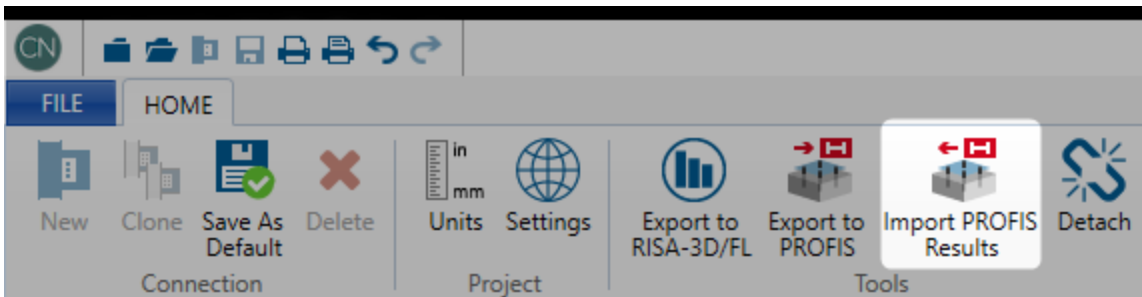

You will then receive the message below if the Import process was successful.

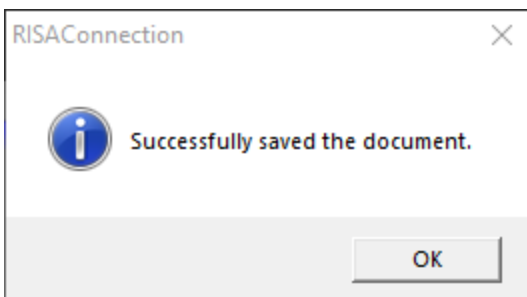

The report will now be located in the file path chosen in the Hilti Profis tab of the Application Settings dialog.

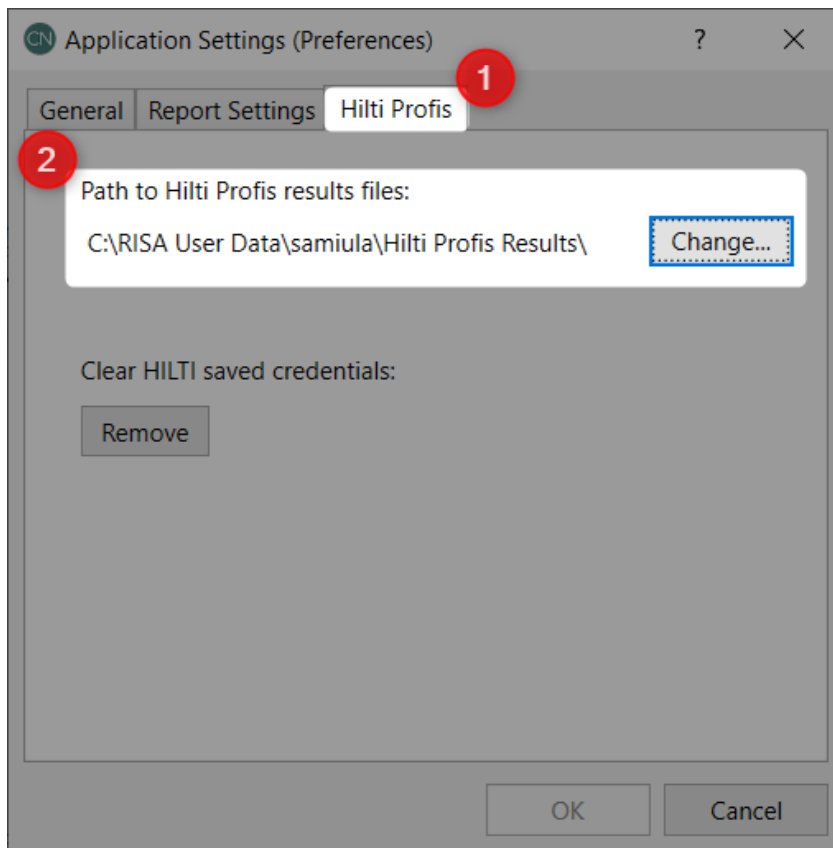

Currently Supported Connections

In order to export to Hilti PROFIS, the connection in RISACONNECTION will need to be assigned as “Single Column Base Plate”.

Supported Data Exported:

- Column Shape and Size
- Column Material
- Base Plate Size, Thickness and Shape
- Loads
- Load Categories and Load Combinations when linked to a RISAFloor or RISA-3D model
- Quantity and Bolt diameter
- Concrete strength and dimensions

Limitations

- The link with RISACONNECTION and Hilti Profis is currently one-way. Any changes made to the Hilti Profis model will not affect the RISACONNECTION model.
- RISACONNECTION only assumes Rigid Base plate theory.
- Custom bolt layouts are not currently supported by the Hilti Profis link.

Changing Hilti PROFIS Accounts

After logging into your Hilti PROFIS account from within RISACONNECTION for the first time, your login credentials are stored for convenience. If you need to switch accounts or clear saved credentials, you can now manage this through the application settings.

To clear saved credentials:

- Open the **Application Settings** menu in RISACConnection.
- Locate the **Hilti PROFIS** tab.
- Click **Remove** under Clear HILTI saved credentials as shown below. This action will remove the stored login information from the application.

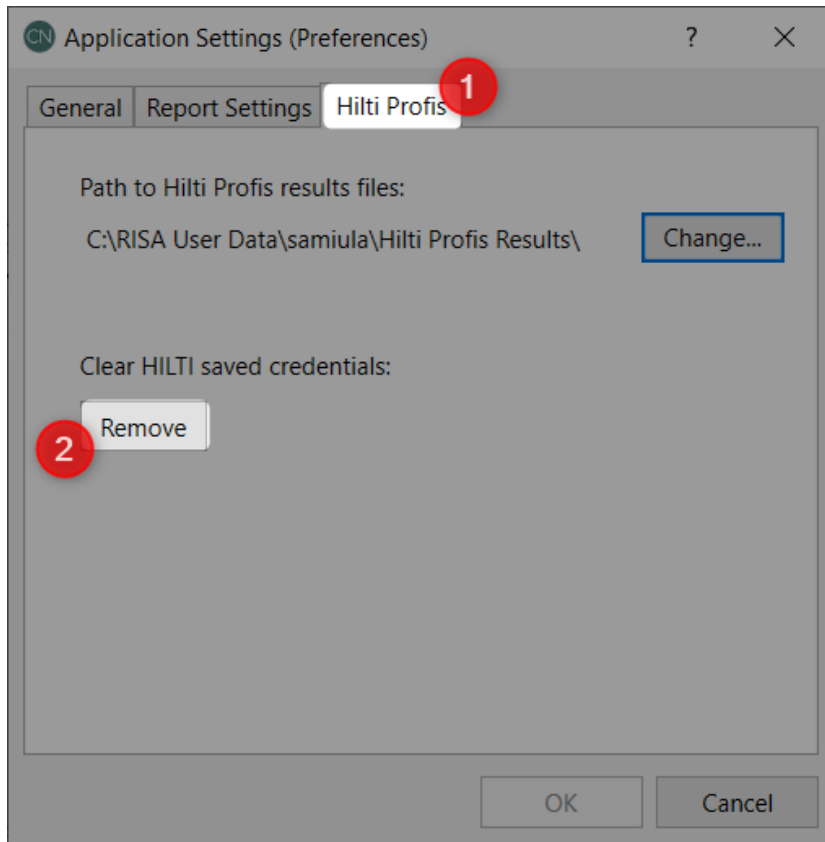

Once credentials are cleared, restart RISACConnection. Upon selecting the **Export to PROFIS** option, you will be prompted to re-enter your Hilti PROFIS login details.

Troubleshooting

If the integration between RISACConnection and Hilti PROFIS is not working properly or if you do not see the File Import section on the right-hand side, please check that the box shown below is checked. This dialog can be found in the Application Settings for Hilti PROFIS.

APPLICATION SETTINGS ✕

GENERAL ^

- Region and language
- Default parameters
- Interaction settings
- Advanced anchor plate calculation settings
- Interfaces to structural calculation software

ANCHOR DESIGN ^

- Anchoring-to-concrete
- Handrail fixing
- Anchoring-to Masonry
- Metal deck fixing

Interfaces to structural calculation software

RISA

Cancel Save

Tekla Structures Integration

When transferring Tekla Structures connections to RISACONNECTION the majority of the behavior is similar to standalone RISACONNECTION. This topic details specific variations from the standard RISACONNECTION behavior. To learn the steps of taking the Tekla Structures model to RISACONNECTION, view the [Tekla Connection Procedure](#) topic.

When first coming into RISACONNECTION from Tekla Structures you will see that the file is populated with all of the VALID connections. Thus, only connections that RISACONNECTION can actually design will be brought over. The act of invoking RISACONNECTION from Tekla Structures (using the  button) will create a RISACONNECTION file automatically.

Connection Grouping

Once you have imported your information in RISACONNECTION, you will see that the connections are grouped in the **Project Explorer**.

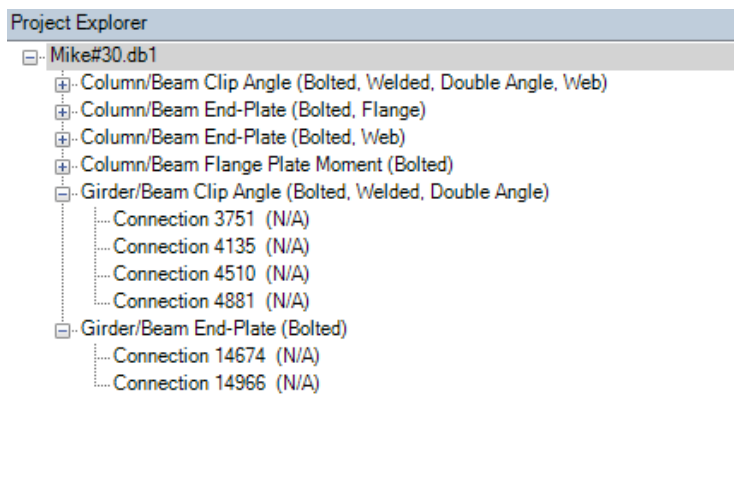

The groups in RISACONNECTION are based on the connection numbers from within Tekla Structures. Within each Tekla Structures connection. However, there are also groupings based on whether the members are framing into a column or beam, whether a column/beam connection frames into the web or flange of the column, and so on. Therefore, a single connection number from Tekla Structures could create a large number of connection groupings in RISACONNECTION.

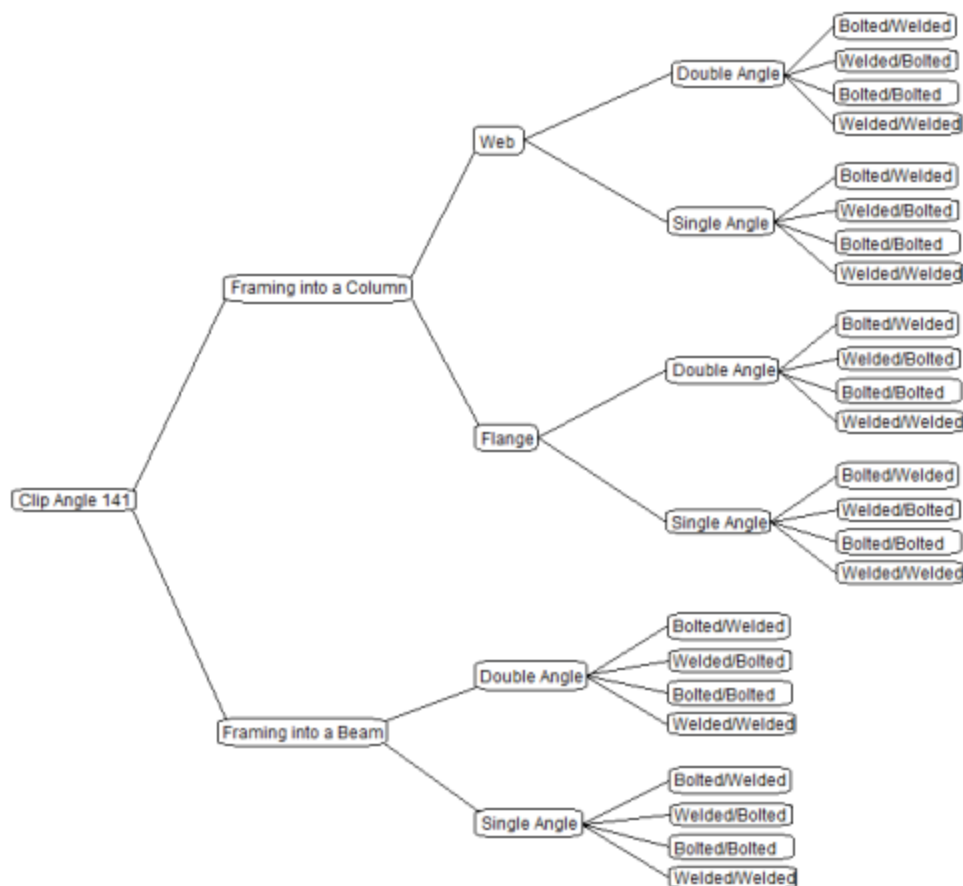

Grouping Behavior

In the Project Explorer there are three levels: Project level, Group level, and Connection level. These levels are nested within each other and allow you to change design and connection properties quickly and easily. There are also properties that can only be changed within Tekla Structures. Here we will discuss these different connection property categories and how to use them properly.

Tekla Structures Level

Items that can only be modified from Tekla:

- Connection Types
- Connection Categories (bolted vs welded, single angle vs double angle, etc)
- Loading
- Member Shapes
- Miscellaneous properties (bolt holes, etc)

If you wish to modify any of these properties you need to go back to the Tekla model, make the change, and then re-export to RISACONNECTION.

Project Level

When you click the project label in the **Project Explorer**, the **Project Properties** are then shown.

Project Properties	
Project Description	
Project Title	Mike#30 db 1
Company	PROJ-BUILDER
Designer	PROJ-DESIGNER
Job Number	PROJ-NUM
Notes	< Notes... >
Project File	
File Path	C:\TeklaStructuresModels\Mike#30\Mike#30
Project Solution	
Design Method	AISC 14th (360-10): LRFD
Bolt Group Analysis Method	Center of Rotation
Weld Analysis Method	Center of Rotation
Consider Bolt Hole Deformation	False
Check Rotational Ductility	False
Check Weld Filler Metal Matching	False

Here you can update information in the **Project Description** fields and some of the options from the **Global Parameters - Solution** tab.

Note:

- When you click the Project in the **Project Explorer** the left screen shows all of the groups in the project and gives a representative view of each.

Group Level

When you click on a Group in the **Project Explorer** then the **Group Properties** are shown.

Group Properties	
Connection	
Connection Title	- Various -
Connection Type	Column/Beam End-Plate Shear Connector
Connection Category	
Column Connection	Bolted
Column Connection Type	Flange
Loading	
Shear Load, kips.	0.0000
Axial Load, kips.	0.0000
Top Column Dist, in.	0.0000
Column Force, kips.	0.0000
Story Shear, kips.	0.0000
Components	
Column Section	W16X50
Beam Section	W16X40
Plate Section	- Various -
Material	A36
Thickness, in.	- Various -
Width, in.	- Various -
Depth, in.	9.0000
Hole Type	STD
Column Bolts	- Various -
Beam Weld	E70
Assembly	
Plate Vertical Position, in.	1.1875

In the Group Properties you can modify connection properties for all of the connections within this group at one time. The grayed out properties are properties brought over directly from Tekla Structures; these properties can not be edited in RISAConnection.

Note:

- If you have changed individual connection properties and then go back to the group, changes here will over-write any of those individual connection changes.
- When you click a Group in the **Project Explorer** the left screen shows all of the connections graphically in that group.
- If an item is labeled **-Various-** it means that there are multiple values in this field for the different connections in this group.

Connection Level

When you click on an individual connection, that connection's properties are shown.

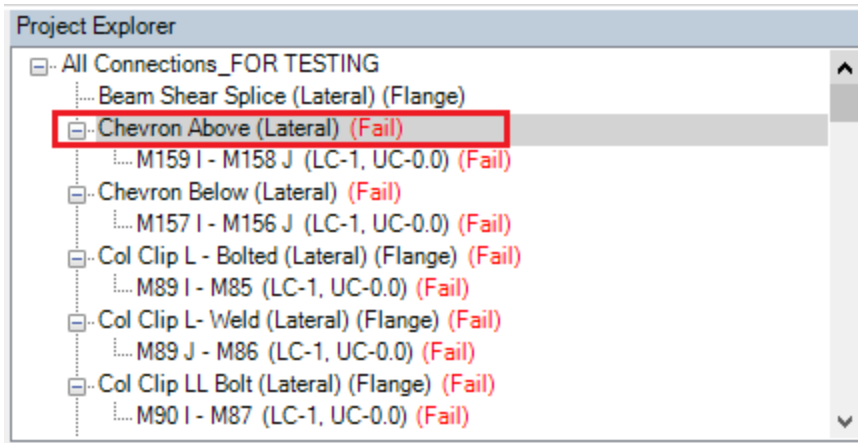

The grayed out properties within an individual connection may be either Tekla controlled, Project level controlled, or Group level controlled. You must go up to those levels to change these properties for these connections.

Loading

The connections must also have their loads applied from Tekla Structures. The loads can be entered in Tekla Structures either from the **Component** itself or from the **End Conditions**. Both of these locations also have a **UDL %/UDL code** that can be used.

Component Loads

RISACONNECTION accepts the Shear, Tension, and Moment fields for each connection. It will also accept a value in the **UDL %** field in place of the **Shear, V**. Please see the [UDL section](#) for more information on how this works.

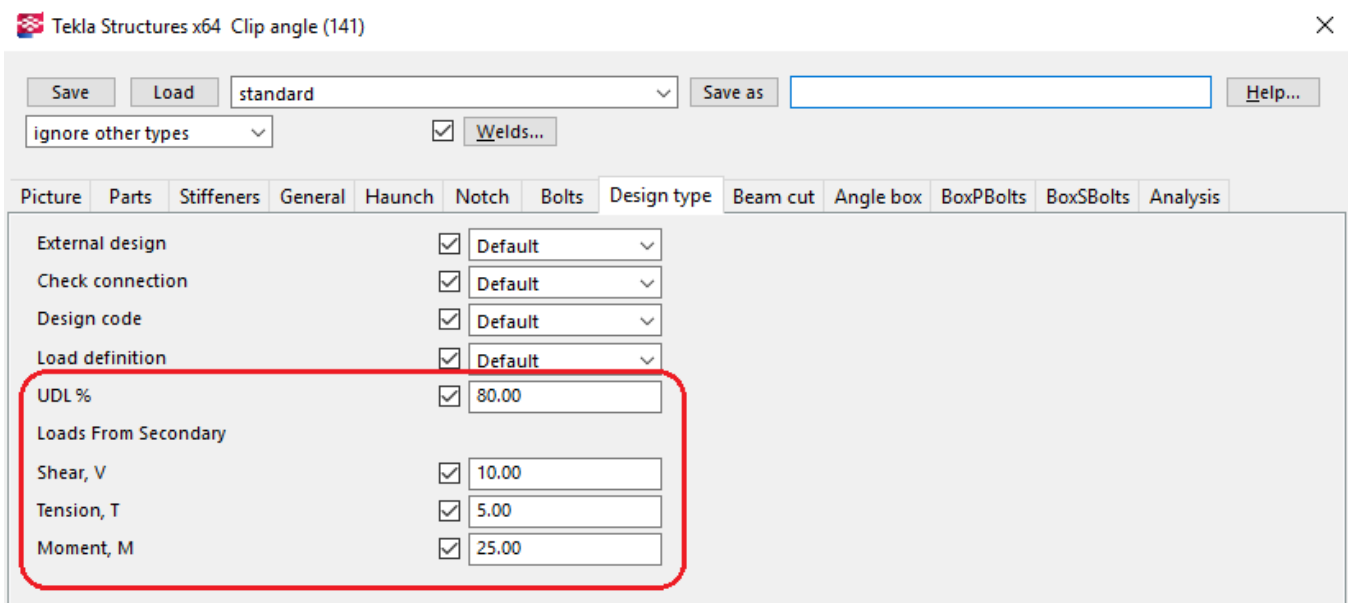

End Conditions

Double-clicking on a member and clicking the *User-defined attributes...* button and going to the **End Conditions** allows a user to define end reactions on a member. These end reactions will then be transferred to RISAConnection appropriately. Note that you can use the **UDL code** field in place of the **Shear, Vy (major)**. Please see the [UDL section](#) for more information on how this works.

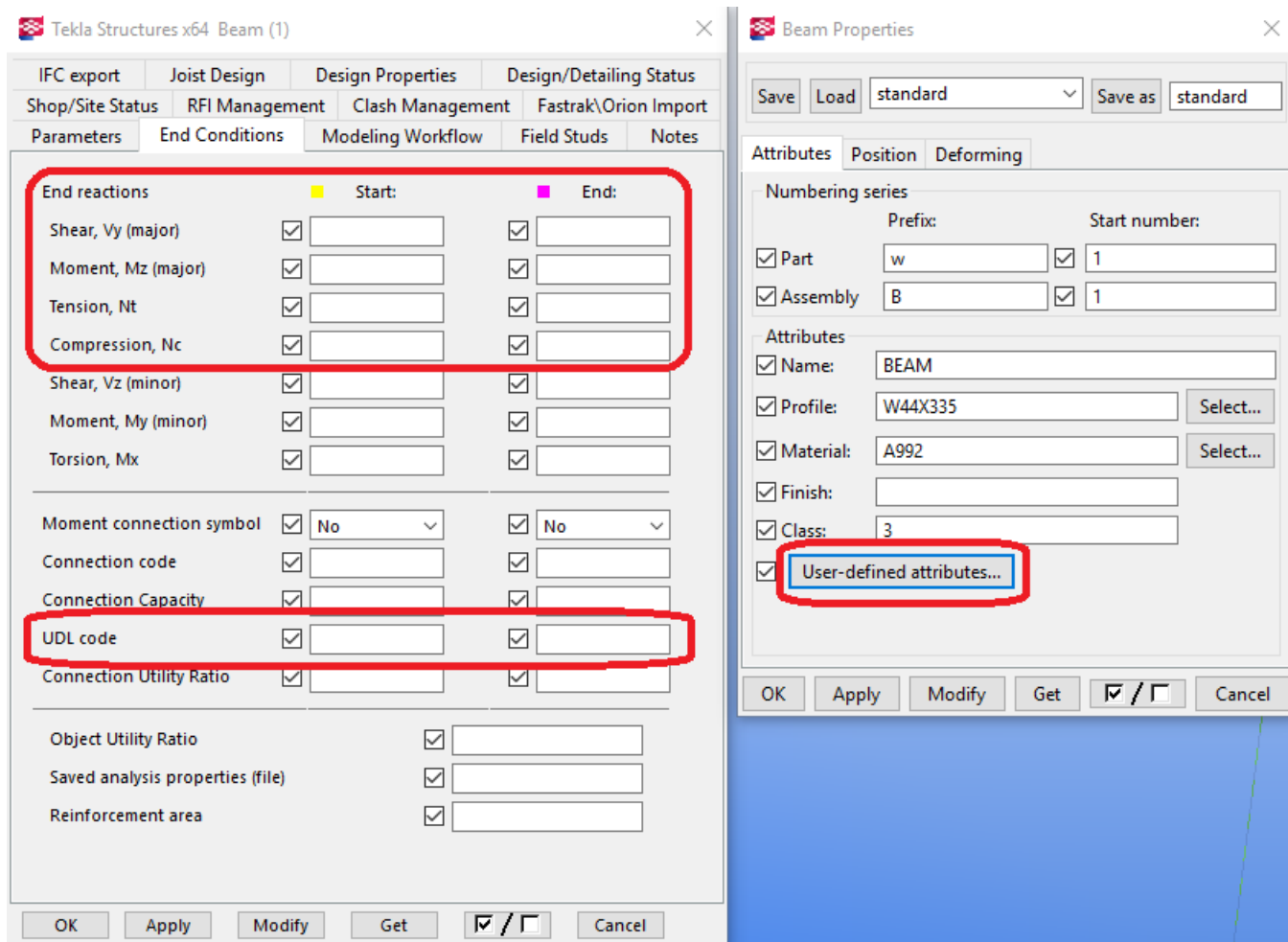

Note:

- If loading is applied to BOTH the component and the end reaction the Component value will be used.
- The **Column Force** and **Story Shear** values are not mapped from Tekla and must be entered manually once in RISAConnection.
- The Tension/Axial force value in Tekla is positive for tension. In RISAConnection, axial force is negative for tension. The RISA-Tekla Link will switch the sign of the force when transferring to account for this.
- Any loading that does not have an input in RISAConnection will not be considered in RISAConnection. Weak-axis shear and weak-axis moments are one example of this.

UDL % (Uniform Distributed Loads)

The UDL % is a way to have the link calculate the design shear forces on a beam in your model. This is done considering the AISC 14th edition manual Tables 3-6, 3-7, 3-8 and 3-9 for wide flanges and channels. These tables have a W_c/Ω_b for ASD and a ϕW_c for LRFD and units of kip-ft. Using the length, L, and the UDL % input the shear force calculation is as follows:

$$V_{ASD} = (UDL \%) * (W_c / \Omega_b) / 2L$$

$$V_{LRFD} = (UDL \%) * (\phi W_c) / 2L$$

This value is what will be brought into RISACconnection in the **Shear Load** field in RISACconnection.

Loading	
Shear Load, kips.	430.777
Axial Load, kips.	5.000
Top Column Dist, in.	0.000
Column Force, kips.	0.000
Story Shear, kips.	0.000

Note:

- UDL % is not supported for shapes other than wide flanges and channels in the AISC 14th edition manual.
- This field is only used for shear forces in beams and we'll be ignored if used in any other conditions.
- If a UDL % value is given in combination with a strong direction shear force (Vy, major) the program will use the shear force and ignore UDL %.
- The default code selected in RISACconnection is the **AISC 14th (360-10): ASD**, thus this initial transfer will always use the ASD value for the UDL % calculation. If you are using LRFD codes you'll need to edit this in RISACconnection and roundtrip the model to get back into RISACconnection with the proper loading.

Solving Connections

Once you get the connections configured properly you need to solve the model. You can solve the model by connection, by group or for the entire project by pressing the appropriate button to solve either a single **Connection**, **Group** or the entire **Project**.

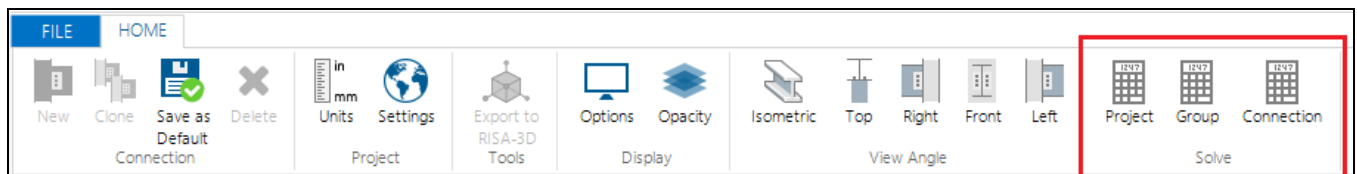

Note:

- If you are using RISACconnection as a standalone program then these solve buttons have no use because the model is re-solved automatically each time a change is made.

Viewing Results (in RISACconnection)

Once you have a connection, a group, or the entire project solved you will be able to view results via the **Project Explorer** or **Reports** tab.

Project Explorer

The **Project Explorer** gives a summary of the design results for the project. Each connection gives a Pass or Fail notification, along with the Max UC and the LC that produced it.

The Group will state "Pass" if all of the connections within the group passes. It will state "Fail" otherwise.

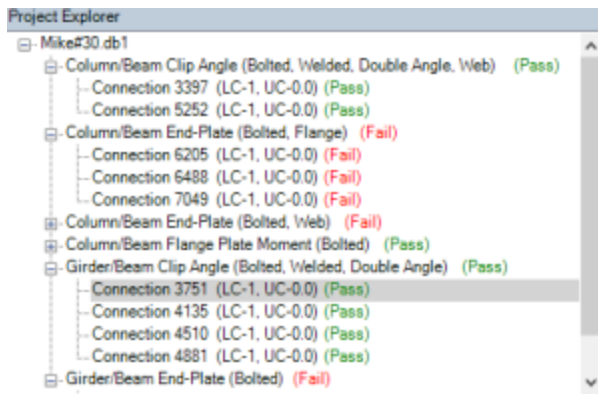

If a property is changed then the connections whose properties are affected will be invalidated. If you modify a single connection then the results for that connection will be invalidated and an (N/A) will be shown.

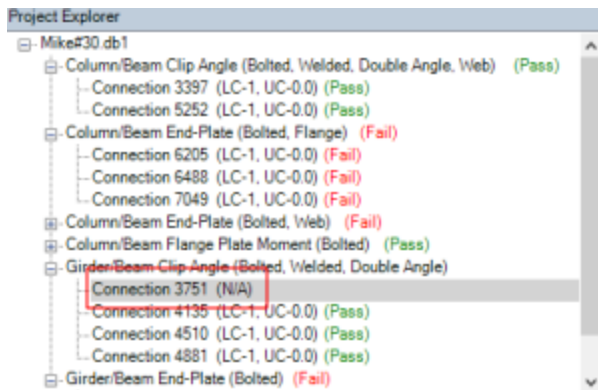

In this scenario you can simply re-solve that connection to get results again.

If you invalidate a group property then that will invalidate all of the connections within that group. If you invalidate a project property, then it will invalidate all connections in the project.

Reports

The **Report** view gives the unity checks for each Limit State. value. The **Reports** section will show which Limit State produced this value.

Connection View for Connection 21

LRFD Results | Members | Components

RISA Connection 21 LRFD

Beam Moment Plate Splice Connection
Connection design

Material Properties:

Left Beam	W410x60	G40.2-350W	$F_y = 350.00 \text{ MPa}$	$F_u = 450.00 \text{ MPa}$
Right Beam	W410x60	G40.2-350W	$F_y = 350.00 \text{ MPa}$	$F_u = 450.00 \text{ MPa}$
Plate	P5.99x309.88x154.76	G40.2-300W	$F_y = 300.00 \text{ MPa}$	$F_u = 450.00 \text{ MPa}$
Moment Plate	P10.01x170.10x459.99	G40.2-300W	$F_y = 300.00 \text{ MPa}$	$F_u = 450.00 \text{ MPa}$

Input Data:

Shear Load	0.00 kN	User Input Shear Load
Moment	0.00 kN-m	User Input Moment
Axial Load	0.00 kN	User Input Axial Force
Puf_c	0.00 kN	Required Flange Force (compression)
Puf_t	0.00 kN	Required Flange Force (tension)

Note: Unless specified, all code references are from AISC 360-10 Collapse All Expand All

Limit State	Required	Available	Unity Check	Result
Geometry Restrictions at Left Beam Web				PASS
Geometry Restrictions at Right Beam Web				PASS
Geometry Restrictions at Left Beam Flange				FAIL
Geometry Restrictions at Right Beam Flange				FAIL
Plate Shear Yield	0.00 kN	166.98 kN	0.00	PASS
Left Beam Shear Yield	0.00 kN	658.12 kN	0.00	PASS

If the connection you are viewing has its results invalidated by changing a connection property, then this message will be shown:

Report not calculated. Press here for Calculation!

If this message is shown then the results shown are invalid. Pressing this message has the effect of solving that individual connection. The program will then give valid results for this connection.

Viewing Results (in Tekla Structures)

Once you have your connections configured properly you can take those results back to Tekla Structures to be viewed in the **RISA-Tekla Link** browser and graphically by pressing the  button in RISACONNECTION.

This will do two things:

- Open the RISA-Tekla Link results viewing dialog and show graphically whether a connection passes or fails.

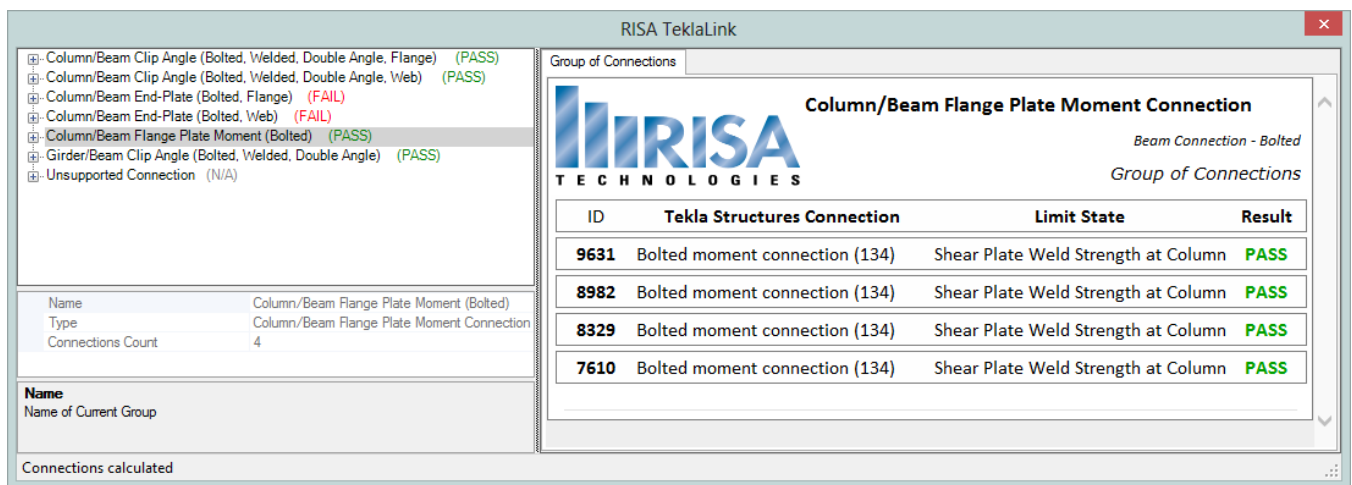

ID	Tekla Structures Connection	Limit State	Result
9631	Bolted moment connection (134)	Shear Plate Weld Strength at Column	PASS
8982	Bolted moment connection (134)	Shear Plate Weld Strength at Column	PASS
8329	Bolted moment connection (134)	Shear Plate Weld Strength at Column	PASS
7610	Bolted moment connection (134)	Shear Plate Weld Strength at Column	PASS

A green cone indicates a passing connection:

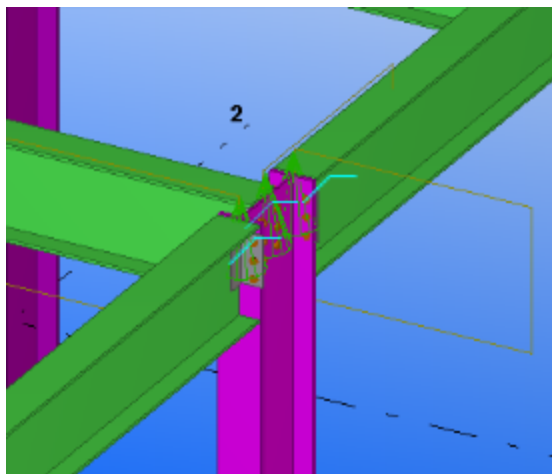

A red cone indicates a failing connection:

- Update the model for updates made in RISACONNECTION. This will physically change your Tekla Structures model to match the RISACONNECTION component properties.

Round-tripping between Tekla Structures and RISAConnection

The Tekla Structures and RISAConnection integration is meant to be used for multiple round-trips. See the [Work-flow Diagrams](#) section for more information on this.

Tekla Structures Integration Procedure

The RISA-Tekla link sends the geometry, connection loads, shape types and connection types automatically from Tekla Structures into RISACONNECTION. This allows you to design your connections in RISACONNECTION and then bring the results back into Tekla Structures to have your structure updated and to view the results.

Here we will walk through the steps required to design connections using this integration. Please view the **RISA-Tekla Link** help file for more detailed information.

1. Completing the Tekla Structures Model

You must first model your structure in Tekla, including the connections and the loading. RISA only supports specific connections with the RISA-Tekla link. If a connection is not one of these supported connections then it will show up as an **Unknown Connection** in the RISA-Tekla link.

2. Sending the Model to RISACONNECTION

After the model is completed in Tekla Structures then pressing the  button will open RISACONNECTION and all connections that are supported will automatically be brought in.

3. Configuring Connections and Solving in RISACONNECTION

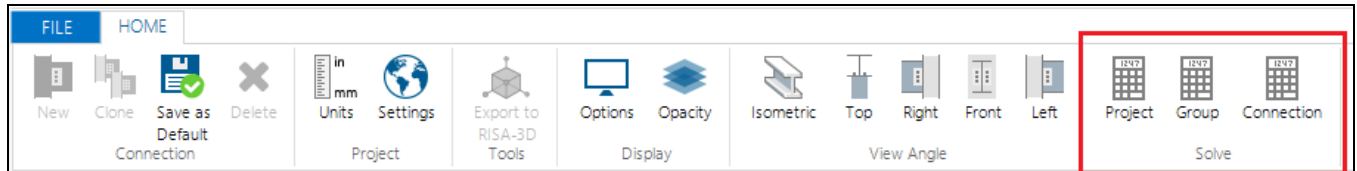

In RISACONNECTION you can configure many of the properties of the connections using the RISACONNECTION interface.

Once the configuring is complete you can then press any of the Solve buttons (shown below) to solve either a single **Connection**, **Group** or the entire **Project**. This will show a **Pass** or **Fail** for each of the connections and allow you to adjust properties to pass the connection



4. Connection Results Viewing in Tekla

How you get back to Tekla Structures from RISACONNECTION is dependent on whether the connections were manipulated with RISACONNECTION on the same machine as Tekla Structures or on a different machine.

- If you have worked on RISACONNECTION on the same machine that you transferred from Tekla Structures:
 - In RISACONNECTION, click the  button to transfer back to Tekla Structures.
- If you worked on the RISACONNECTION file on a separate machine from the one running Tekla Structures:
 - Place the RISACONNECTION model file back (.rcn extension) in the Tekla Structures model directory.
 - Open the Tekla Structures model.
 - Press the  button in Tekla Structures. DO NOT press the  button as this will overwrite your RISACONNECTION model again with the properties from Tekla Structures.

In either of the above cases this will do two things:

1. Open the RISA-Tekla Link results viewing dialog and show graphically whether a connection passes or fails.

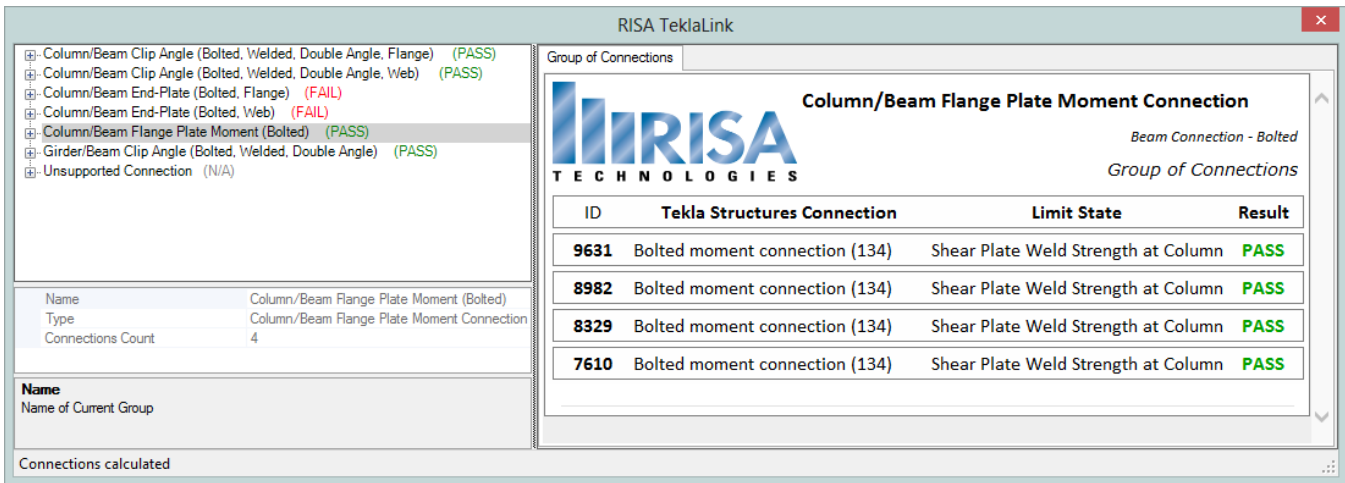

For more information on this dialog see the [Application Interface](#) topic.

A green cone indicates a passing connection:

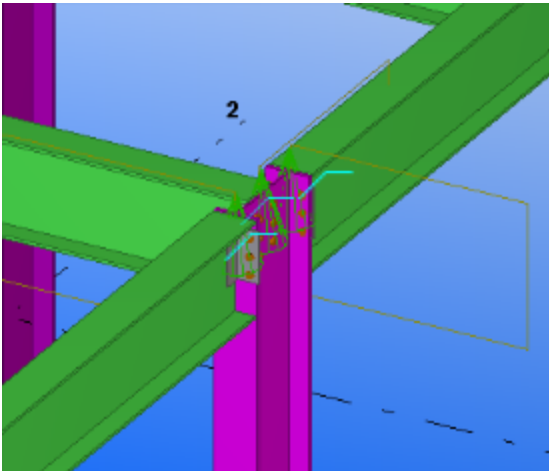

A red cone indicates a failing connection:

2. Update the model for updates made in RISAConnection. This will physically change your Tekla model to match the RISAConnection component properties.

Workflow Diagrams

If the Tekla Structures computer will also be using RISAConnection, use this workflow:

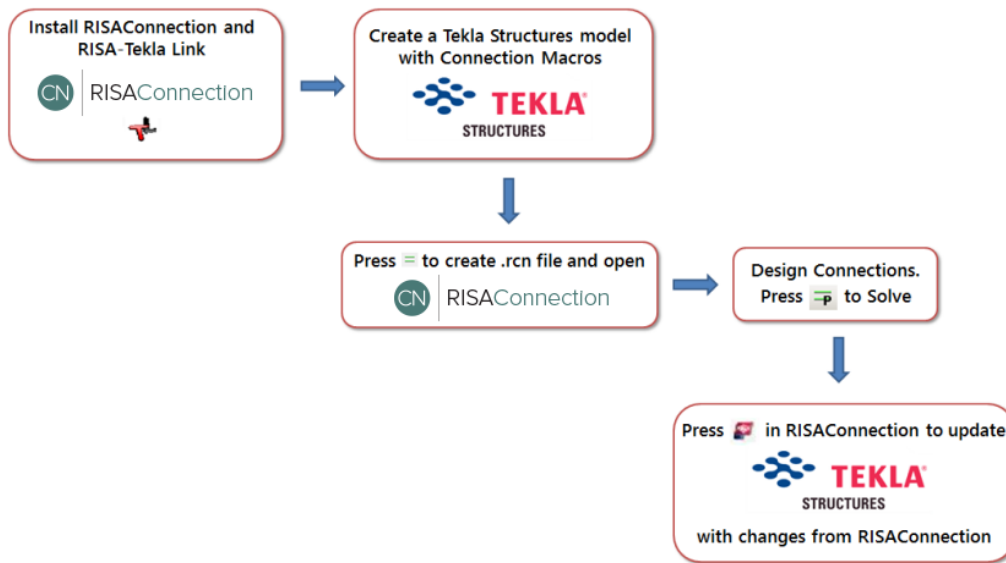

If the Tekla Structures computer will be different than the one using RISACONNECTION, use this workflow:

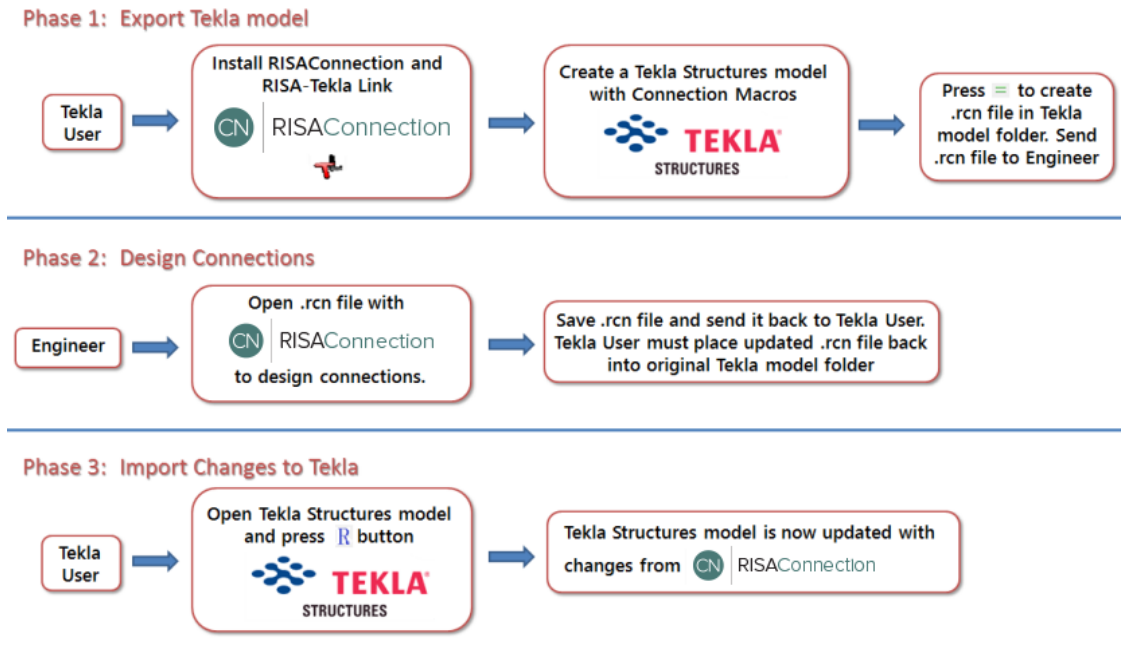

DXF Export

You may export 2D Views of connections as DXF files. This feature provides compatibility with any other program that can read DXF files. This includes most major CAD programs.

Exporting DXF Files

You can export the connection by going to **File-Export**:

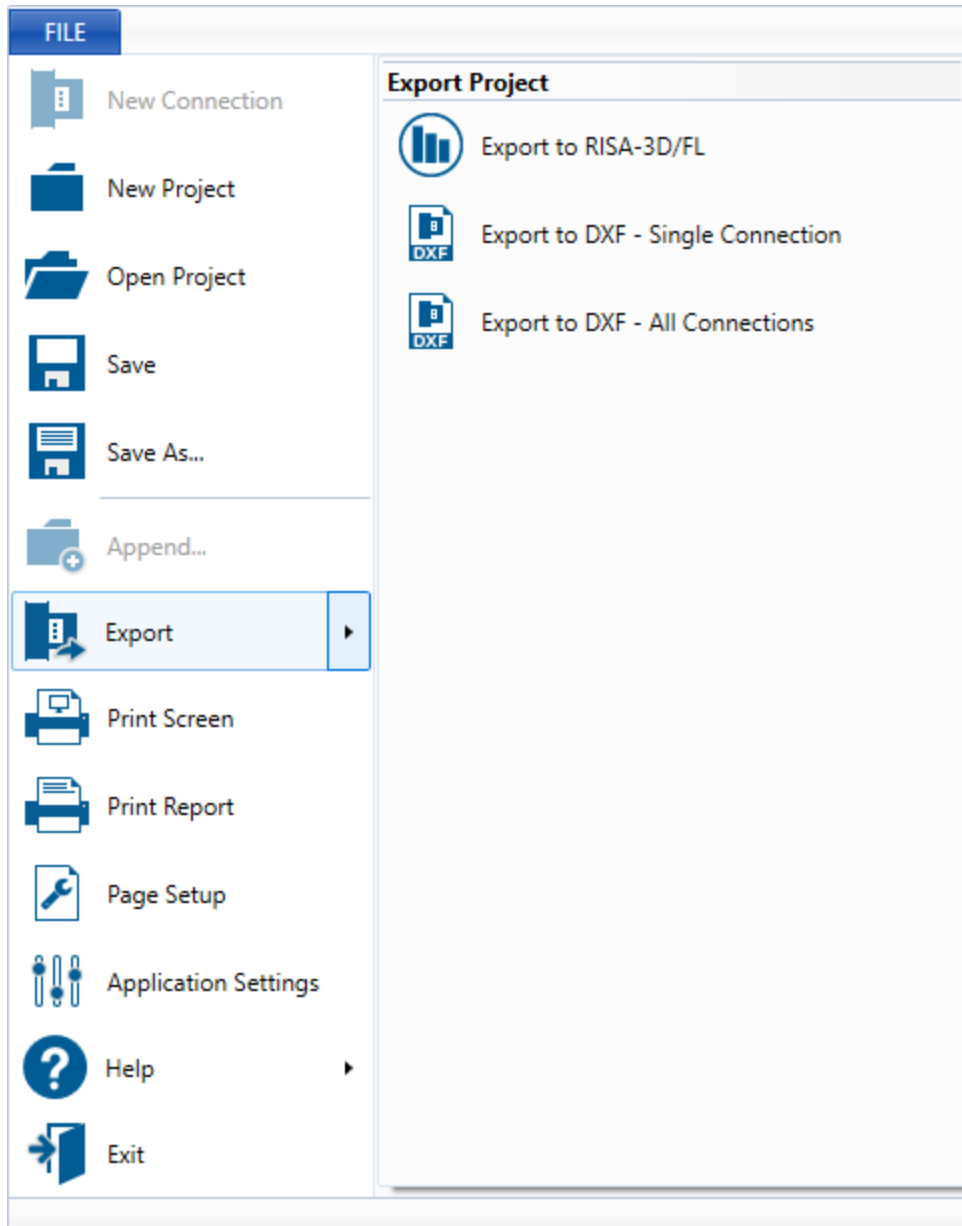

You can select to Export a single Connection, or you can export all the connections from entire project.

The **Single Connection** will create a 2D drawing for each 2D View available for that connection. Each view is framed inside a box and the Connection title view name is shown. All the elements are described with labels.

The **All Connections** option will create 2D drawings for each 2D View available for every connection. Each view is framed and the connection title and view name is shown. Each connection will be shown in a vertical array. All the elements are described with labels.

Export DXF File

DXF Export Options

Select DXF Units: in

CAD Scale Factor: 1.000

Show Dimensions

DXF Export Layer Options

Beam/Column/Girder: MEMBERS

Plates/Angles: CONNECTORS

Bolts: BOLTS

Welds: WELDS

Labels: LABELS

Dimensions: DIMENSIONS

OK Cancel Clear

CAD Scale

Enter the scale factor that will cause the full scale RISA model to be scaled up or down to the desired drawing scale. For example, if you created a model that you wanted scaled down to 1/4"=12", the factor would be 0.020833, which is (.25/12).

DXF Units

Select the units you desire the CAD model to be created in. The options for the DXF units are No Units inches, feet, mm, cm, and meters.

Show Dimensions

The "Show Dimensions" checkbox in the DXF Export Options allows users to include dimensions in their DXF exports. The units for these dimensions are set by the "Select DXF Units" parameter just above this checkbox.

DXF Export Layers Options

Each type of element will be placed on a different layer. You can enter the names of the layers for the different elements of the connection.

Printing

RISAConnection gives the ability to print in two ways: you may print the current view of your screen (everything in the Connection View) or you may print a report of your selected project details through the Report Creation Wizard.

Print Current View

When you click on the **Print Current View** button, or select **Print Current View** from the **File** menu, the program will automatically print whatever information you currently have on display in your **Connection View** window of the program. This could be the Results Report view, the 3D View, one of the 2D Views, etc.

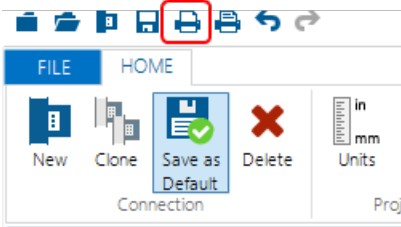

Report Creation Wizard

When you click on the **Print** button, or select **Print** from the **File** menu, the program will open the **Report Printing** dialog. This dialog allows you to quickly select several items to print for one or several connections at once. This way you only have to click the Print button once in order to print a full report. Below are explanations of each option within the dialog.

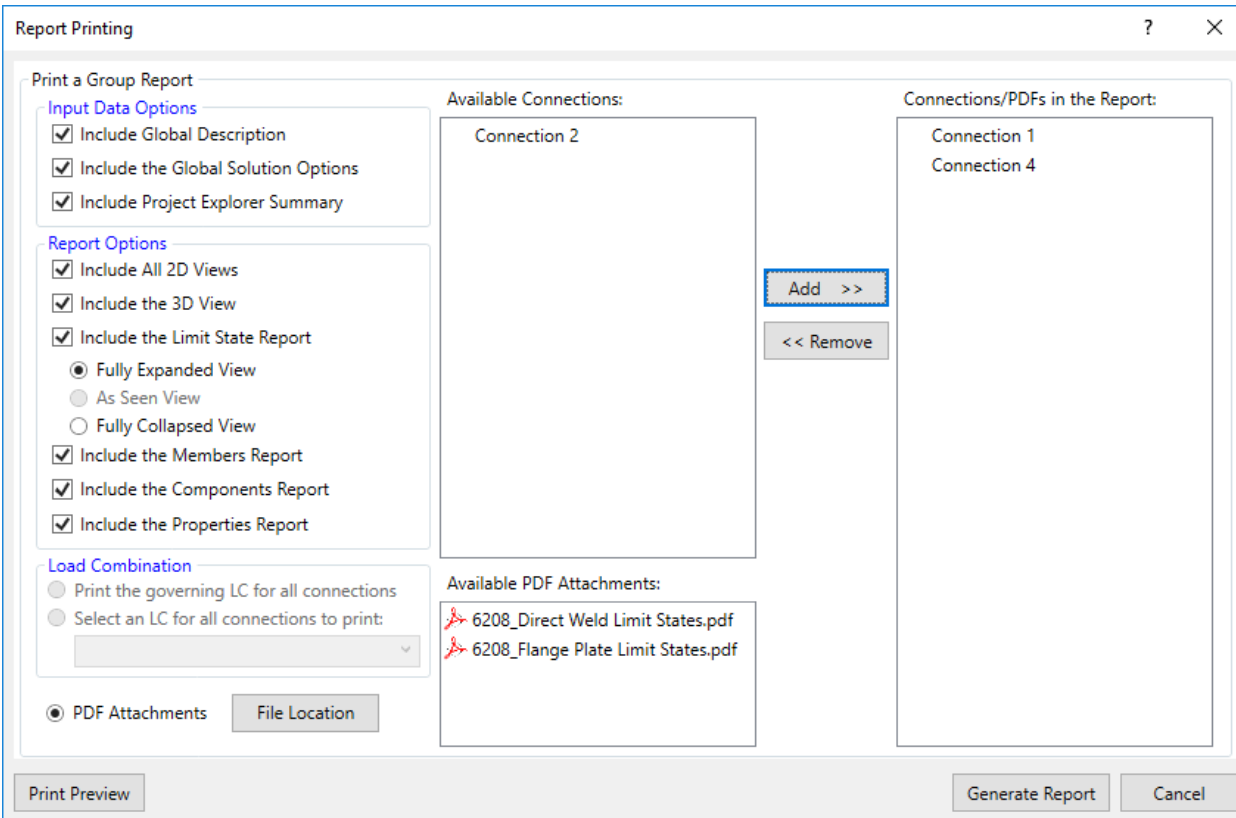

Input Data Options

These options allow you to select (or unselect) the basic information about the whole project. This includes:

- **Include Global Description** - This will include a section in your report which reports all the information from the *Description* tab of the *Global Parameters* dialog.
- **Include Global Solution Options** - This will include a section in your report which reports all the information from the *Solution* tab of the *Global Parameters* dialog.
- **Include Project Explorer Summary** - This will include a section in your report which reports a summary list of all the connections in your project. This will look like the information from the [Project Explorer](#) in the upper right-hand corner of your screen.

Report Options

These options allow you to select (or unselect) the specific information about each of the connections that you have selected into the [Connections in the Report](#) column. This includes:

- **Include All 2D Views** - This will include the 2D Views for your connection, as seen on the *2D View* tab of your Connection View. The printed size of these images is controlled by the **Size of the 2D/3D Image** control on the [Report Settings](#) dialog.
- **Include the 3D View** - This will include the 3D View for your connection, as seen on the *3D View* tab of your Connection View. The printed size of this image is controlled by the **Size of the 2D/3D Image** control on the [Report Settings](#) dialog.
- **Include the Connection Properties** - This will include all your input information from the [Connection Properties](#) window in the lower right-hand corner for your screen.
- **Include the Limit State Report** - This will include the results report either in a **Fully Expanded View** (all the limit state details are expanded), or in a **Fully Collapsed View** (only the limit state labels and summary information is displayed). If you have selected just one connection to include with your report and this is the same connection that you are currently viewing, you will also have the open to print the **As Seen View**. This means that whatever state your limit state results report shows will be exactly what prints with the report. This means that if you have some limit states expanded and others collapsed, the printed report will show exactly this.
- **Include the Members Report** - This will include all the member-specific information in your report. This is the same information that is displayed on the *Members* tab of the results report.
- **Include the Components Report** - This will include all the component-specific information in your report. This is the same information that is displayed on the *Components* tab of the results report.

Load Combination

If you have created your RISACONNECTION model from exporting results from RISA-3D or RISAFloor, you will have load input from each load combination. When printing the report, you can select a single Load Combination to show results for, or print the governing (Max LC) for each connection.

- This is not available when you are using RISACONNECTION in stand alone mode (without RISA-3D or RISAFloor integration).

PDF Attachments

You may also add external PDF results to your RISACONNECTION report. Select the **File Location** to look for your PDF files, and then they will show up under the **Available PDF Attachments** section where you can move them to the right side to print in the report.

Available Connections and Connections in the Report

These columns allow you to select which connections (or group of connections) shall be included in the report output. To select connections to be included in the report simply highlight them (you can highlight a single connection or a group of connections) then click on the **Add** button to move them into the right-side column. This will tell the dialog that you want these connections included in the report. Similarly you can remove them using the **Remove** button.

Print Preview

Pressing the **Print Preview** button will open the **Print Preview** dialog.

Print Preview
— □ ×

Close

Technical Support

Technical support is an important part of the RISACONNECTION package. There is no charge for technical support for all users with a **current** subscription of RISACONNECTION. Technical support is very important to the staff at RISA Tech, Inc.. We want our users to be able to reach us when they are having difficulties with the program. However, this service is not to be used as a way to avoid learning the program or learning how to perform structural modeling in general.

Hours: 6AM to 5PM Pacific Standard Time, Monday through Friday

Before contacting technical support, you should typically do the following:

1. **Please search the Help File or General Reference Manual.** Most questions asked about RISACONNECTION are already answered in the Help File or General Reference Manual. Use the table of contents or index to find specific topics and appropriate sections. We go to great lengths to provide extensive written and on-line documentation for the program. We do this in order to help you understand the features and make them easier to use.
2. If you have access to the Internet, you can visit our website at risa.com and check out our **Downloads** and **Support** section for release notes, updates, downloads, and frequently asked questions. We list known issues and product updates that you can download. So, if you think the program is in error you should see if the problem is listed and make sure you have the latest release.
3. Make sure you understand the problem, and make sure your question is related to the program or structural modeling. Technical Support does not include free engineering consulting.
4. Take a few minutes to experiment with the problem to try to understand and solve it.

For all modeling support questions, please be prepared to send us your model input file via email or postal mail. We often will need to have your model in hand to debug a problem or answer your questions.

Email: support@risa.com. This method is the **best** way to send us a model you would like help with. Most email packages support the attachment of files. The input file you would send will have a *.rcn extension. Make sure you tell us your name, company name, Key ID, phone number, and give a sufficient problem description.

Phone Support:(949) 951-5815. You can also call. But keep in mind that this works best only if your question is not model specific and therefore doesn't require us to look at your file.

Index

#

- 2D View 11
- 2t Linear Limit 223
- 3D View 11
- 8 Bolt Unstiffened 164
- 8t Elliptical Limit 223

A

- Accessing Defaults Viewer 46
- Additional Considerations of Seismic Brace Force Distribution 218
- Analysis Methodology for Chevron Brace Connections 196, 198
- Analysis Methodology for Knee Brace Connections 201
- Analysis Methodology for the Diagonal Brace Connections 190
- Anchor Bolt Forces 237
- Anchor Reinforcement 228
- Anchor Reinforcement - Shear 228
- Anchor Reinforcement - Tension 228
- Anchorage Design Checks 245
- Anchorage Type 228
- Angle Leg Bending 76
- Application Interface 5
- Assembly 20
- Available Connections 286
- Available Vertical Brace Connection Types 186
- Axial Force in Moment Connections 165

B

- Base Material 93
- Base Plate Connections 225

- Base Plate Design Checks 239
- Beam Axial Load 219
- Beam Flange to End Plate Stiffener Buckling 162
- Beam Flexural Rupture 67
- Beam Tension Rupture 67
- Bearing Length, Y 237
- Bearing Limitation 77
- Block Shear Strength 68
- Bolt Bearing Strength 89
- Bolt Constructability 63
- Bolt Geometry Restrictions 62
- Bolt Group Analysis Method 38
- Bolt Group Eccentricity 78
- Bolt Layouts 228
- Bolt Moment Strength 160
- Bolt Prying in Shear 85
- Bolt Shear Strength 81
- Bolt Tensile Strength 82
- Bolted Flange Plate (BFP) 181
- Bolted Stiffened/Un-stiffened Extended End Plate (BEEP) 181
- Bolts
 - Slip Critical 54
- Bolts Located Between Horizontal Welds 61
- Brace Eccentricity 207
- Brace Location 228
- Brace to Base Plate Design 238
- Brace to Base Plate Design Checks 247
- Branch Axial Yield 154
- Branch Flexural Yield 155

C

Canadian Code 52

- C1 53
- End Plate Moment Connections 53
- Limitations 57
- Mw 52

Check Rotational Ductility 38

Check Seismic Brace Area- 222

Check Weld Base Mat. Thickness 40

Check Weld Filler Metal Matching 38

Chevron Vertical Brace 195

CJP Weld Strength 101

Clip Angle Interaction Check 76

Column Buckling Reduction Factor, χ 158

Column Flange Bending 126

Column Flange Bending in Shear Connections 125

Column Flexural Yielding 126

Column Moment Connection Checks 123

Column Panel Zone Shear 135

Column Stress Interaction Parameter, Q_f 158

Column Web Axial Yielding 129, 138

Column Web Buckling 134

Column Web Crippling 133

Column Web Crippling in Shear Connections 132

Column Web Flexural Yielding 138

Column Web Out of Plane Checks 137

Column Web Punching Shear 129, 137

Column Web Yielding 131

Column Web Yielding in Shear Connections 131

Complete Joint Penetration 101

Components 17

Compression Buckling 72

Concentrated Force Location 124

Connection Category 15

Connection Grouping 248

Connection Modeling Process 42, 46

Connection Properties 14

Connection View 10

Connections in the Report 286

Consider Bolt Hole Deformation 38

Continuous Beam over Column Moment Connection 169

Controlling Load Calculation 222

Controlling Load Combination 212

Coped Beam Checks 119

Coped Beams 54

Creating a Connection 43

Creating a Project 42

CSA HSS Limitations 141

Customizing RISACONNECTION 33

D

Defaults Viewer 47

Description Tab 36

Design Checks 51

Design Code 37

Design Force Calculations for Each Directional Load Case 214

Design Methodology 237

Design Methodology for Chevron Brace Connections 195

Design Procedures 52

Detach 259

Determining the Seismic System 211

Diagonal Vertical Brace 190

Directional Load Cases 213

Display r_0 and r_u Calculations for Welds 41

Double 103

Doubler Plates 171

DXF Export 282

E

Eccentric Moment Calculation 15

Effective 239

Effective Throat 102

Elastic Weld Strength 94

End Plate

 Flush 165

End Plate Flexural Yielding 163

End Plate Moment Checks 159

End Plate Moment Reversal 165

End Plate Shear Rupture 164

End Plate Shear Yielding 163

End Tee Unbraced Lengths 157

Erection Stability 58

F

Filler Metal 102

Fillet Weld 98

Flange Plate Tension Yield 64

Flexural Buckling 75

Flexural Rupture 72

Flexural Rupture Strength 119

Flexural Yielding 71

Full Shear Ecc. Considered 38

G

Geometry Checks 58

Global Parameters 36

Governing Design Forces 215

Graphic Display 27

Graphical View of the Hinge Line 223

Graphical View of the Whitmore Section 203

Gross and Net Areas 67

Grout Pad 234

Gusset to Column Orientation 228

H

Hilti PROFIS

 Exporting 261

 Importing Results 264

 Supported Connections 267

Hilti Profis Tab 35

How to Create a Base Plate Connection 225

How to Create a Seismic VBrace
 Connection 208

HSS Beam to Column Moment Connection 156

HSS Checks per the CIDECT Manual 56

HSS Combined Interaction 155

HSS Flexural Plastification 149

HSS Limitations 140

HSS Punching Shear 142

HSS Sidewall Local Axial Yielding 152

HSS Sidewall Local Flexural Yielding 153

HSS Transverse Plastification 145

I

ICR Weld Strength 97

Importing a Connection from a RISAFloor or
 RISA-3D Model 176

Importing a Vertical Brace from RISA-3D 210

Include AISC 15th Out of Plane Web Checks 41

Input or Imported Brace Loads 212

Input Properties 228

K

k and N Assumptions 124

Kicker Brace 200

Knee Brace 200

Knee Brace WorkPoints 201

Knife Plate Unbraced Lengths 157

L

Lateral Torsional Buckling Strength 121

License Agreement 2

Limitations- Base Plate Connections 227

Loading 15, 235

Loading/Load Combinations 254

Local Web Buckling Strength 120

M

Maximum Bolt Spacing 62

Maximum Edge Distance 63

Menus and Toolbars 5

Minimum Bolt Spacing 62

Minimum Edge Distance 62

Moment Arm 123

Moment Connections into a Column Web (Weak Axis) 166

N

Net Section Modulus 119

Non-Eccentric Weld Strength 98

O

OCBF Connection Strength 217

Ordinary Moment Frame Connections 181

Overview 1

P

Panel Zone 55

Partial Joint Penetration 100

PDF Attachments 285

PJP Weld Strength 100

Plate Interaction for Welded Connections 56

Plate Tearout 69

Plate Washers 235

Plot Options 30

Preferences 33

Print Current View 284

Print Preview 286

Printing 284

Project Explorer 13

PZ Deform. Considered 40

Q

Qf 158

R

RBS Dimensions 179

RBS Limitations 180

Reduce Available Bolt Strength by Prying Effects
Factor Q 41

Reduced Beam Section (RBS) 178

Report Creation Wizard 284

Report Logo Tab 34

Reports 13

Required Flange Force 159

Results 51

RISA-3D Imported Loads 211

RISAConnection Behavior

Hilti PROFIS 261

Tekla 270

RISAFloor and RISA-3D Integration 248

Rotational Ductility 53, 58

Round-tripping 258

Round-tripping Between Tekla Structures and
RISAConnection 278

S

SCBF Connection Strength 217

Seismic Brace Design Force 212

Seismic Brace Limitations 212
Seismic Brace Slenderness 222
Seismic Detailing 15
Seismic Detailing DXF Output 224
Seismic Gusset Rotation Capacity/Clearance-
222
Seismic Input Values 211
Seismic Joint Fasteners 222
Seismic Load Distribution Calculations (Govern-
ing) 222
Seismic Load Distribution Calculations (Load
Case XX) 222
Seismic Loading Combinations 222
Seismic Loading Directions 213
Seismic Moment Checks 182
Seismic Moment Connection 174
Seismic Moment Input Values 178
Seismic Moment Limitations 178
Seismic Rotational Ductility 222
Seismic Vertical Brace Checks 221
Seismic Width to Thickness Ratios 222
Seismic Workpoint Limitations 222
Seismic Yield Stress Limitations 222
Setting a new default 48
Shear Rupture Strength 64
Shear Tab Interaction Checks 73
Shear Yield Strength 64
Shortcut Keys 9
Sign Convention 23
Skewed 110
Slip Critical Considerations 80
Snet 119
Solution Tab 37
Solving Connections 255
Stability 58
Stabilizer Plate 53, 63

Staggered 105
Static Friction Coefficient 240
Stiffener Checks for Moment Connections 170
Story Force Calculations 219
Story Shear 136
Strength vs. Serviceability 80
System Requirements 1

T

Tapered Gusset Plate 187
Tapered Gusset Plates 236
Technical Support 2, 287
Tekla Integration - Grouping Behavior 271
Tekla Integration - Viewing Results (in RISACon-
nection) 275
Tekla Integration- Connection Grouping 270
Tekla Structures Integration - Loading 273
Tekla Structures Integration - Solving Con-
nections 275
Tekla Structures Integration Procedure 279
Tension Rupture 65
Tension Yield 64
Top of Column Distance 124
Transfer Forces 193

U

Unbraced Length 167-168
Units 22

V

Verify Bolt Prying 162
Vertical Brace Connections 186
Viewing Results (in Tekla Structures) 277

W

Web Development 102

Web Weld 178
Weld 92
Weld Access Holes 55, 178
Weld Analysis Method 38
Weld Geometry 92
Weld Size Limits 101
Weld Strength 94
Welded Un-reinforced Flange Welded Web
(WUF-W) 180
Welds to Face of HSS 157
Whitmore Section 202
Wide Flange Brace Members 204
Width to Length Ratio 190
WorkPoint Location 236

X

XOVS 239

X

χ 158